

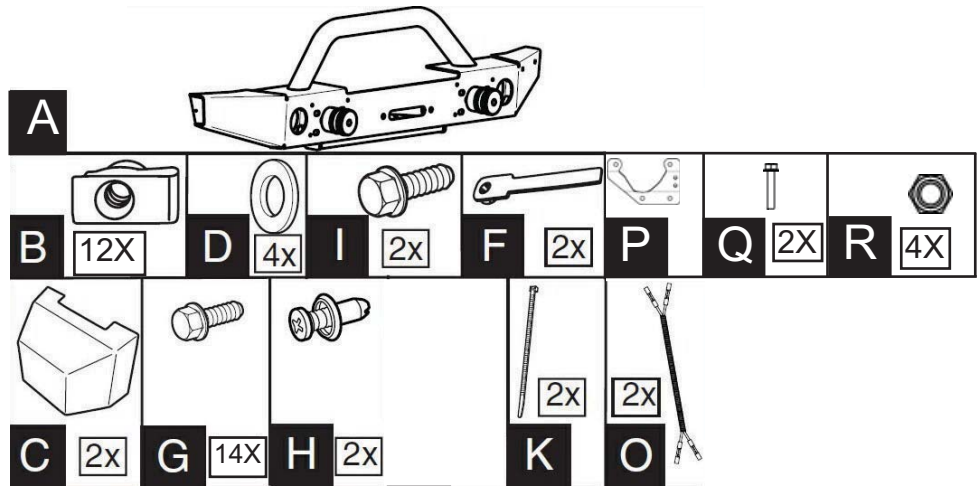

JEEP WRANGLER

Front Bumper

#82213575, 82213578



See steps 1 - 11, then proceed to steps 20 - 33
 * Required to install winch

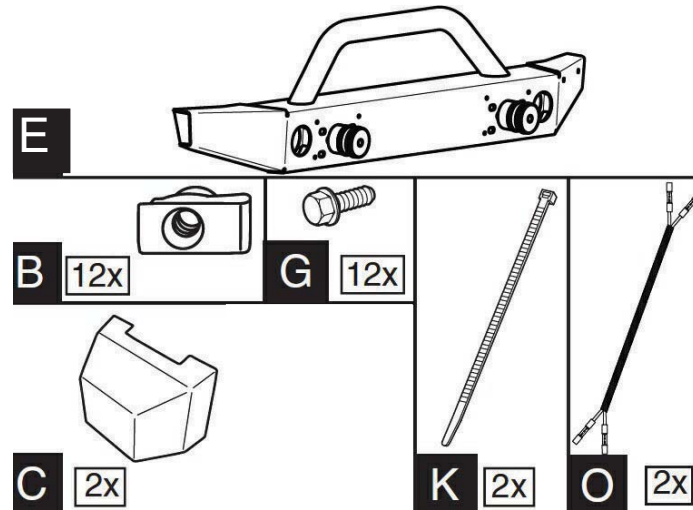

See steps 1 - 19

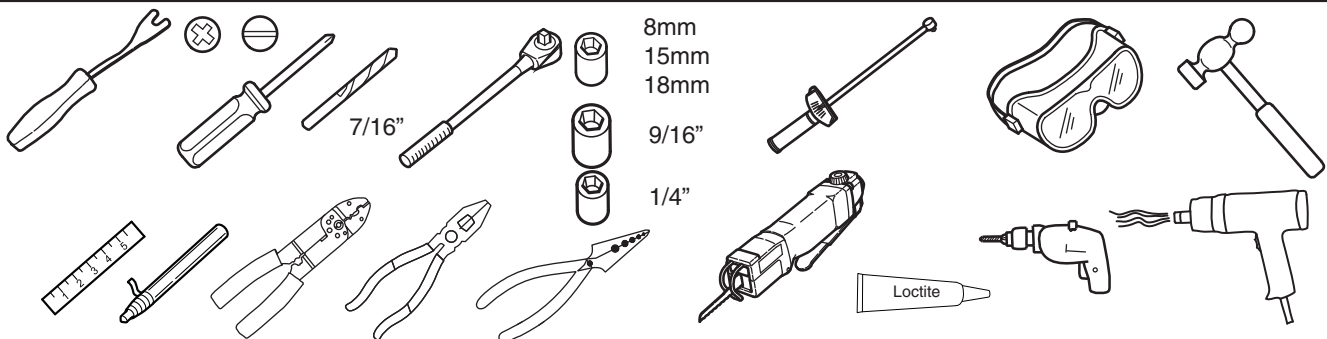

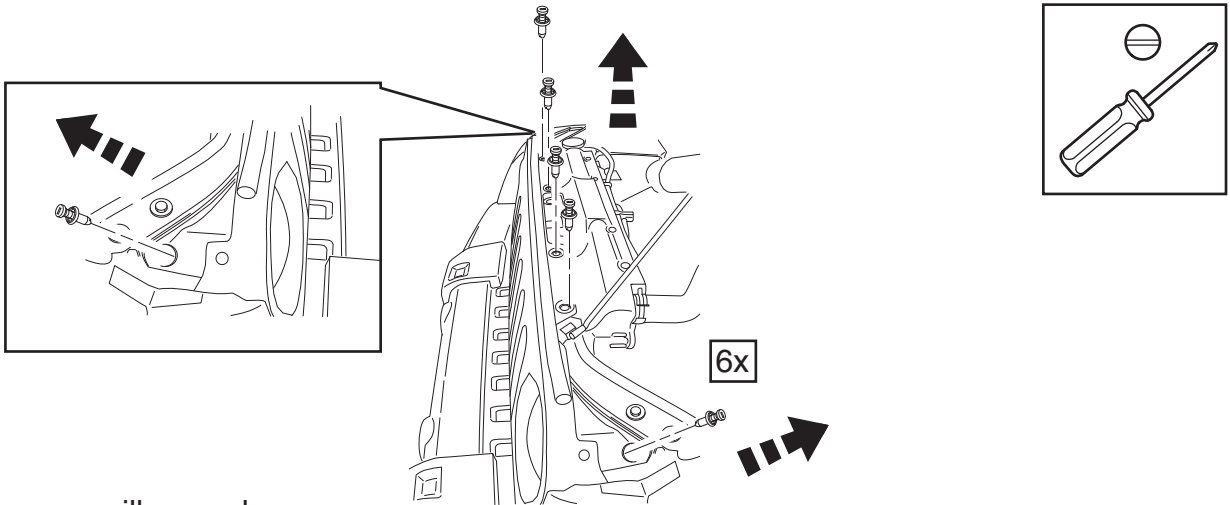

Remove grille panel.

1

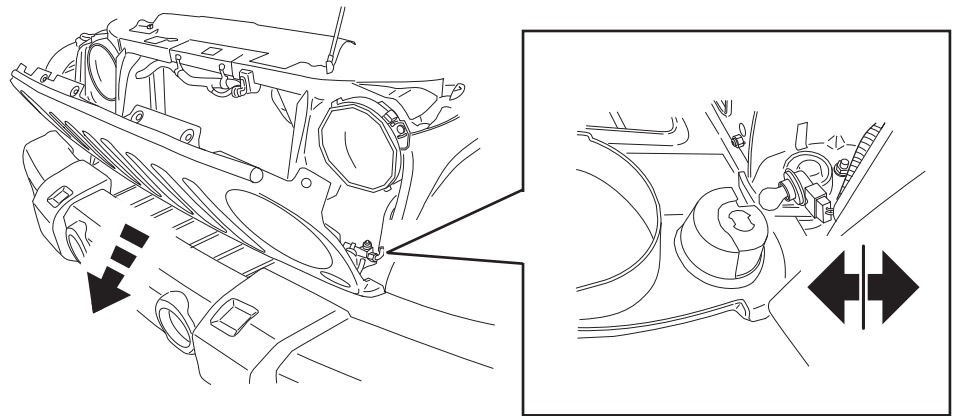

Disconnect bulb assembly on each side.

2

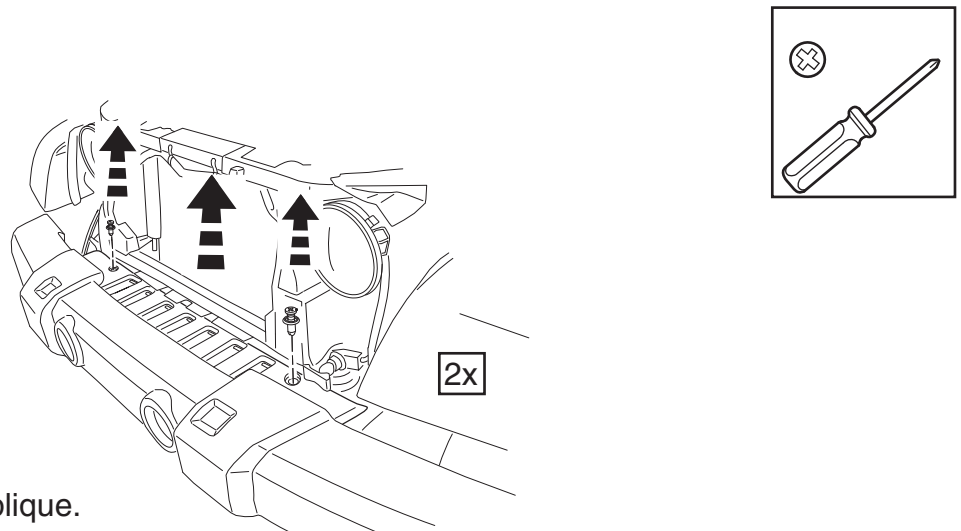

Remove bumper applique.

3

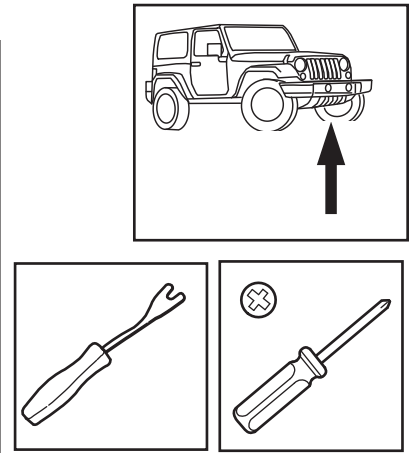
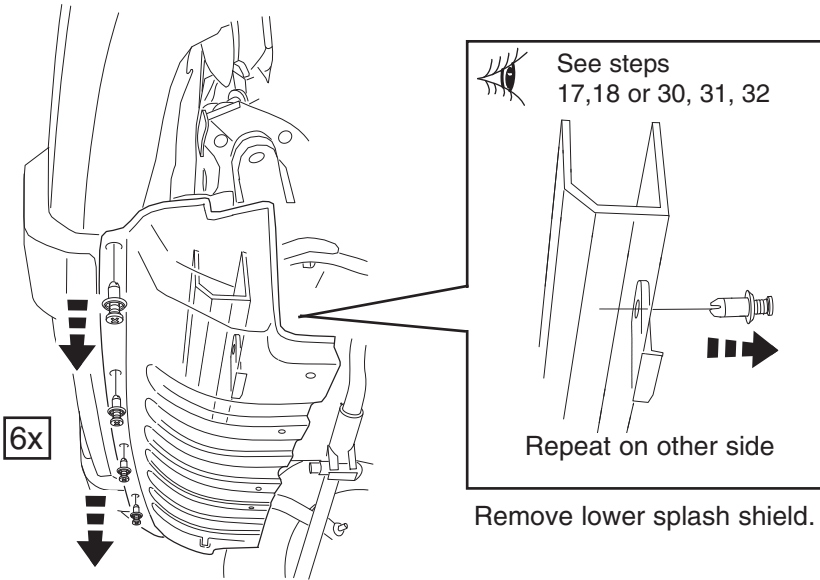

4

Remove lower splash shield.

See steps 12,14, 22 & 24

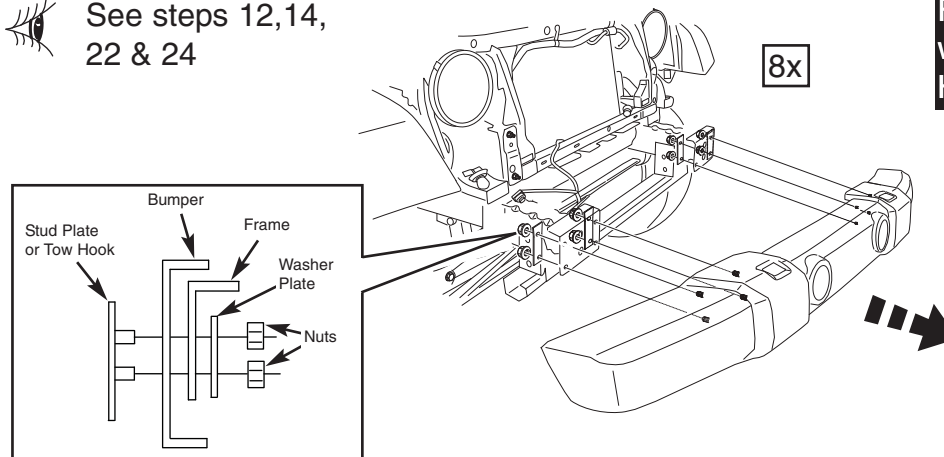

Fascia shown without Tow Hooks

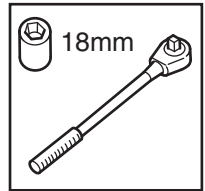

Save nuts & washer plates for re-use in steps 12, 14, or 22, 24.

5

Disconnect harness from fog lamp if equipped and place fascia assembly on the floor.

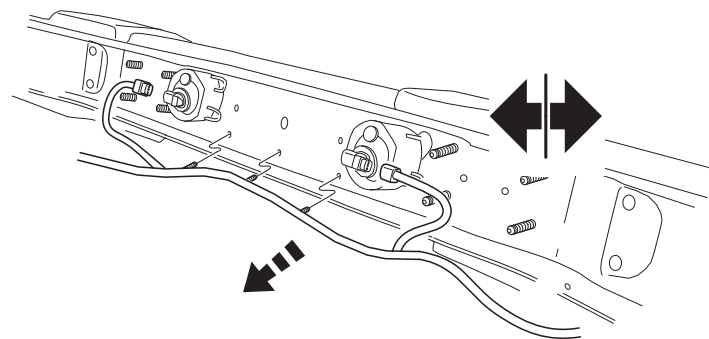
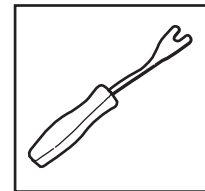

6

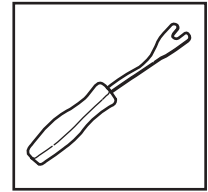
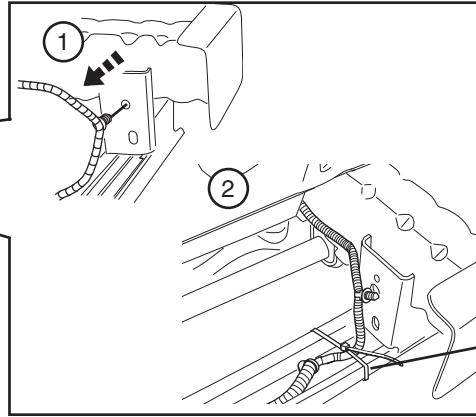
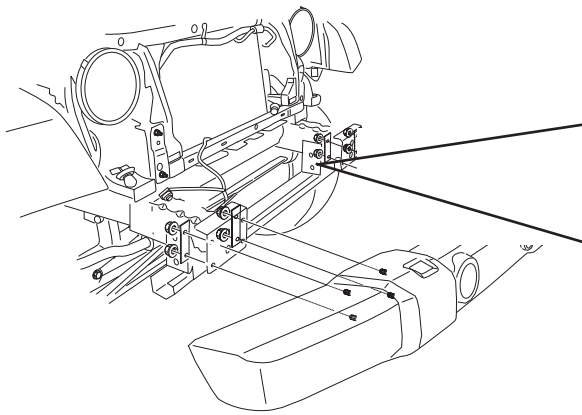

K
2x

1) Disconnect wire harness.
2) Using Item K, tie wrap securely in place to vehicle on both sides.

7

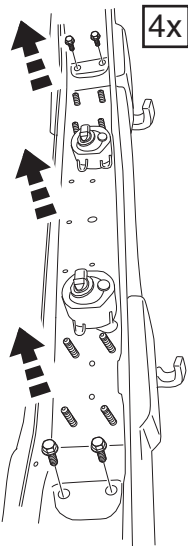

4x

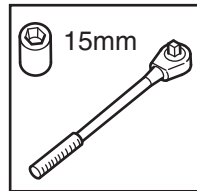

15mm

Remove crossmember to access stud plates. If equipped, remove tow hooks.

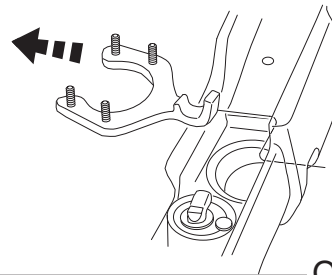

See step 14

Fascia with
Tow Hooks

OR



See step 12

Fascia without
Tow Hooks

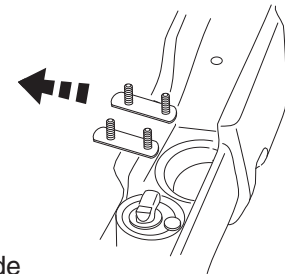

8

9

Repeat on other side

82213578 only



See step 11

Remove fog Lamps from bumper

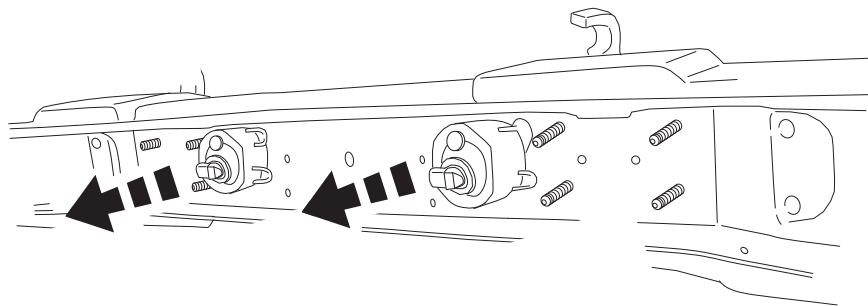
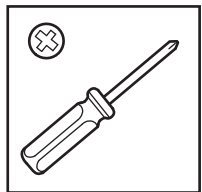

Remove and Save the eight fasteners from the fog lamps so they can be reused later to re-install the fog lamps.

10

Install fog Lamps to bumper & torque

3.9 N.m / 35 In-lbs

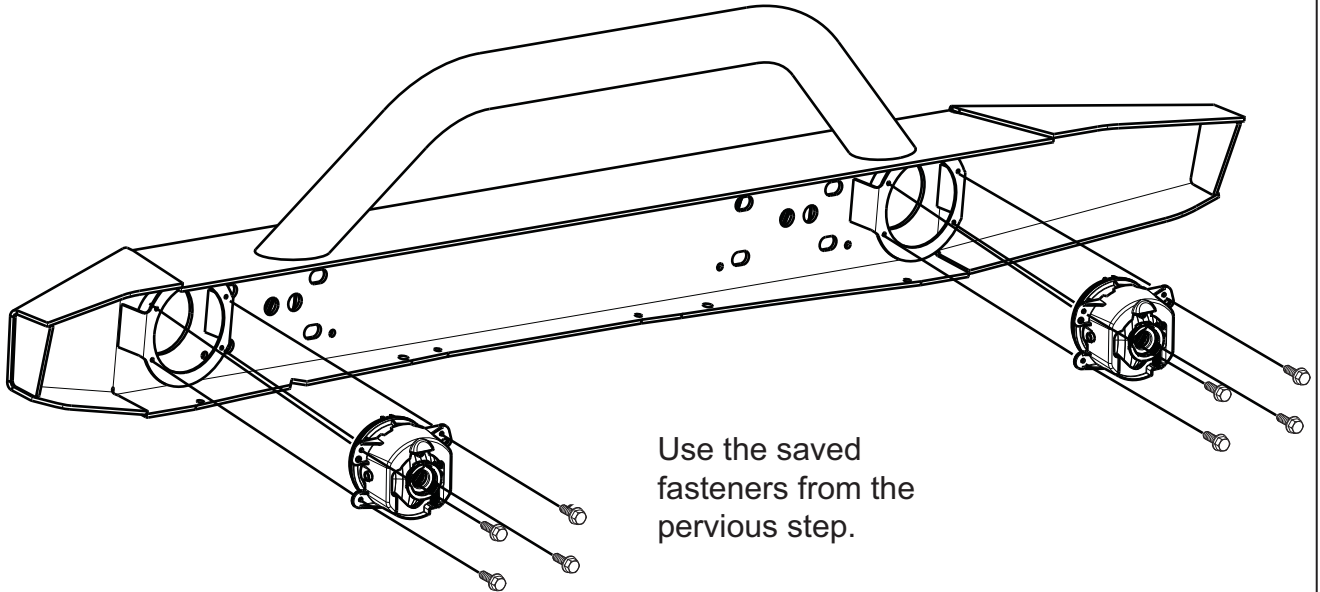
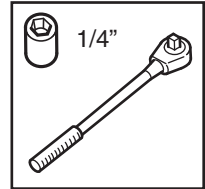

Use the saved fasteners from the pervious step.

11

Kit # 82213578 (Shown) - Vehicle without Tow Hooks

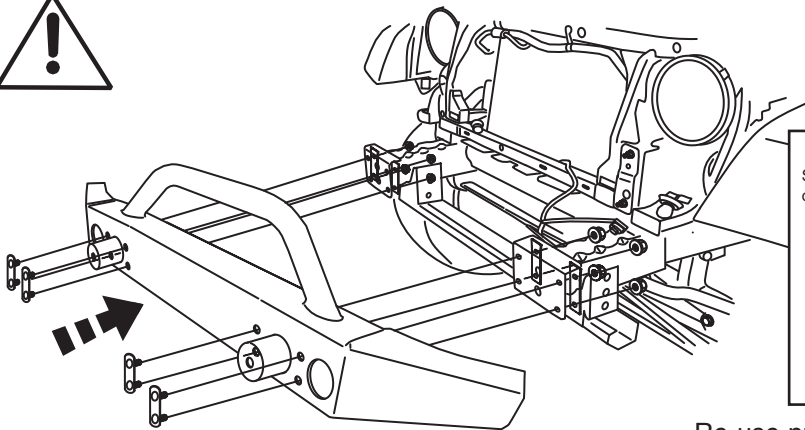

100 N.m / 75 ft-lbs

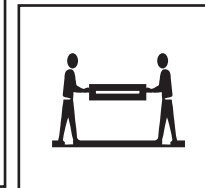
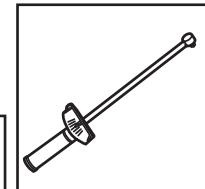
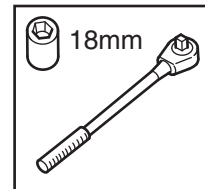
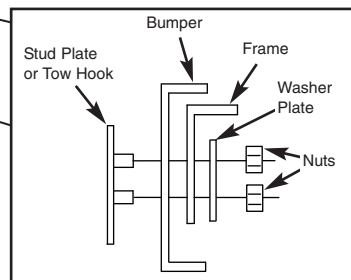

Re-use nuts and washer plates from Step 5 and stud plates from Step 9.

After leveling the bumper for best appearance, torque hardware as shown.

12

Vehicles without Tow Hooks, opening at bottom.

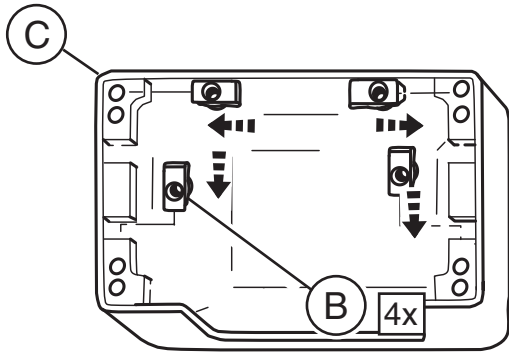

Install U-nuts as shown, correct orientation is important for proper installation.

13A

Kit # 82213578 (Shown) - Vehicle with Tow Hooks

Do not over-torque
11 N.m / 96 in-lbs.

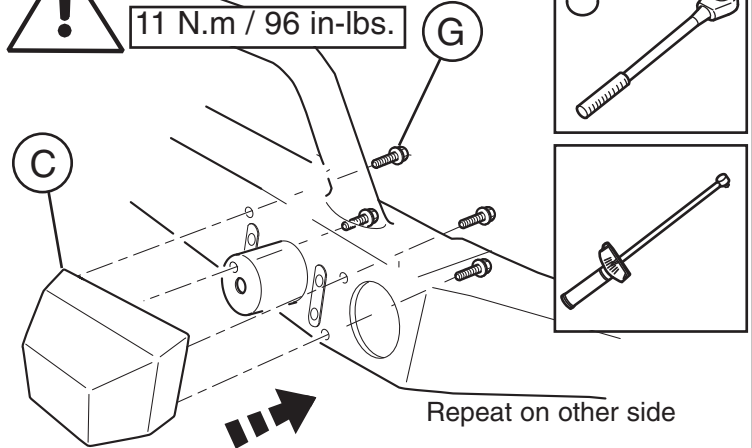

Repeat on other side

13B

Note: View without Tow Hook

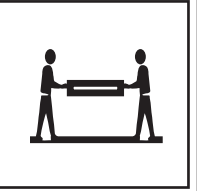
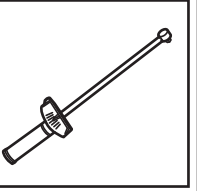
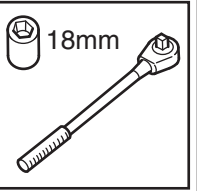
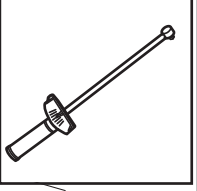
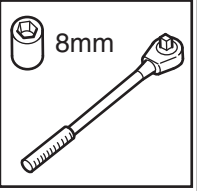

Vehicles with Tow Hooks

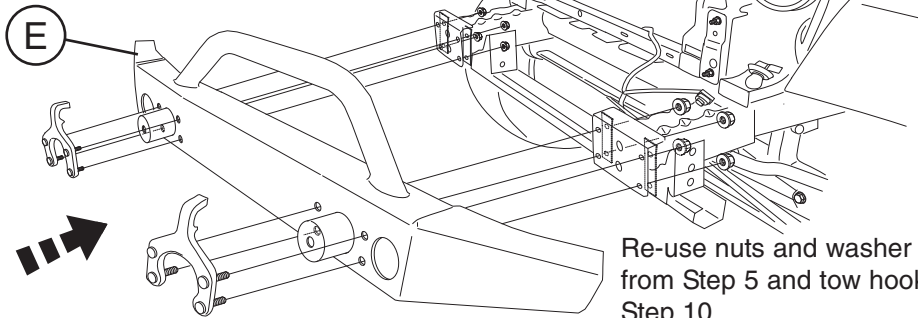

Re-use nuts and washer plates from Step 5 and tow hooks from Step 10.

After leveling the bumper for best appearance, torque hardware as shown.

14

100 N.m / 75 ft-lbs

Vehicles with Tow Hooks, opening at top.

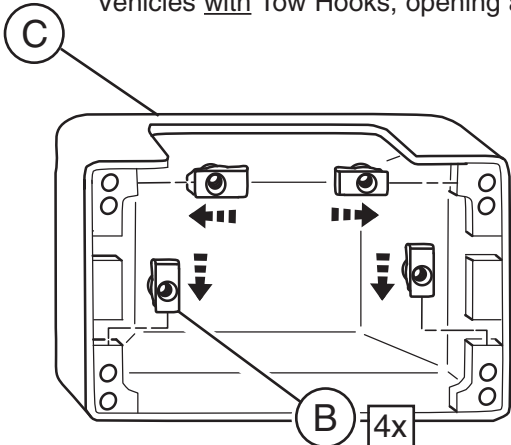

Install U-nuts as shown, correct orientation is important for proper installation.

15A

Do not over-torque
11 N.m / 96 in-lbs.

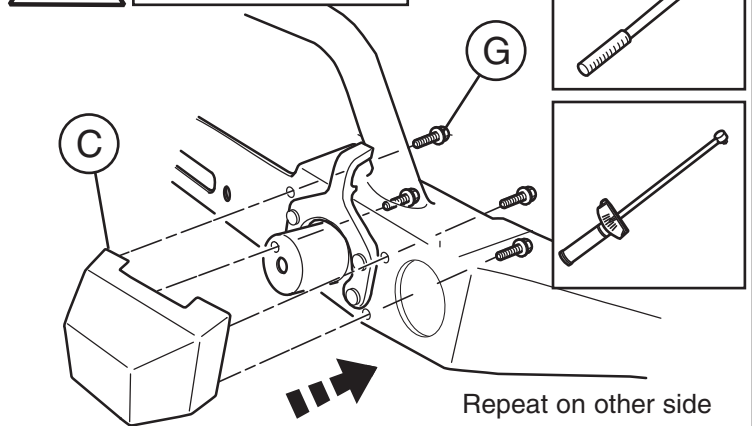

Repeat on other side

15B

Note: View with Tow Hook

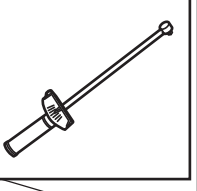
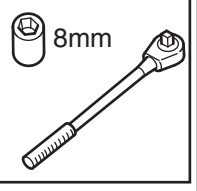

Modify jumper harness and connect fog lamps & wire harness

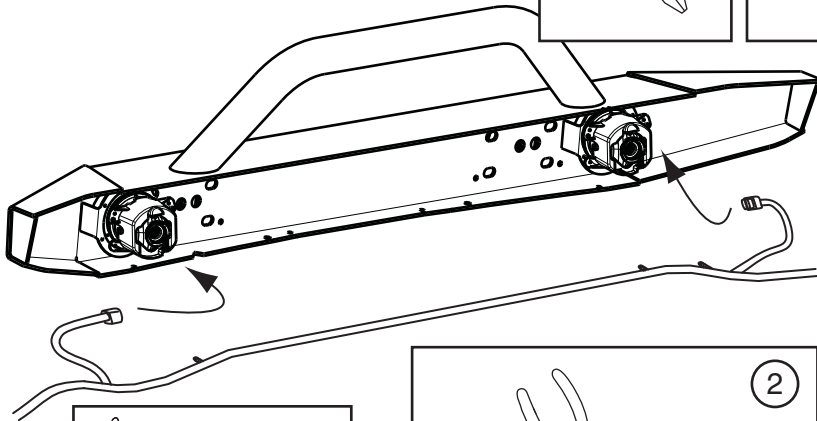
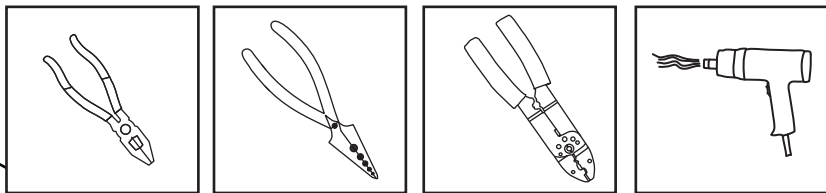

1) Pull back convoluted tubing near the connector. Cut the two wires 3 inches back from the connector.

2) Strip all four wire ends .30".

3) Using harness (Item O), crimp the White wire on the harness to each stripped ends of the White wire on the vehicle harness. Repeat process using the Black wire on the harness and vehicle harness.

4) Using a Heat Gun, shrink the butt connectors to the wires. Replace any convoluted tubing. Place provided convoluted tubing over the spliced wires.

5) Repeat process for other side of harness.

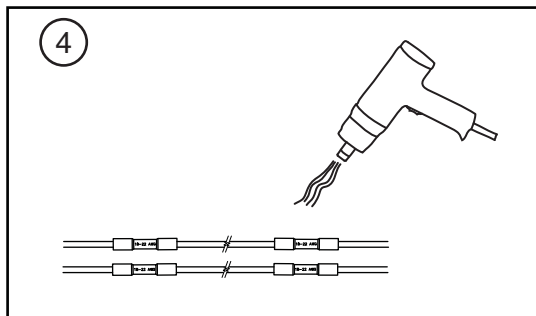
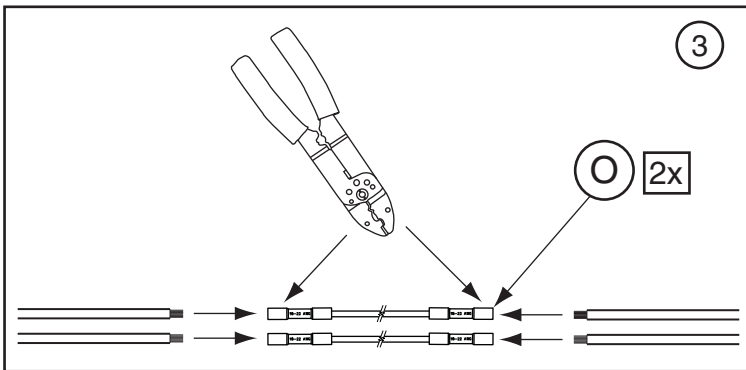
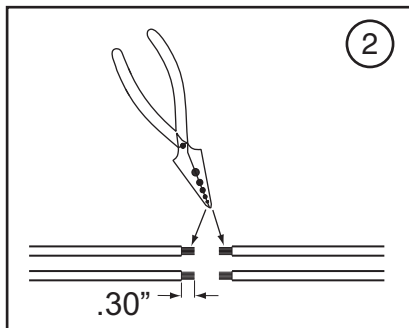
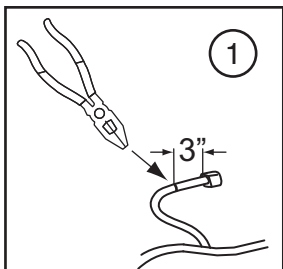

16

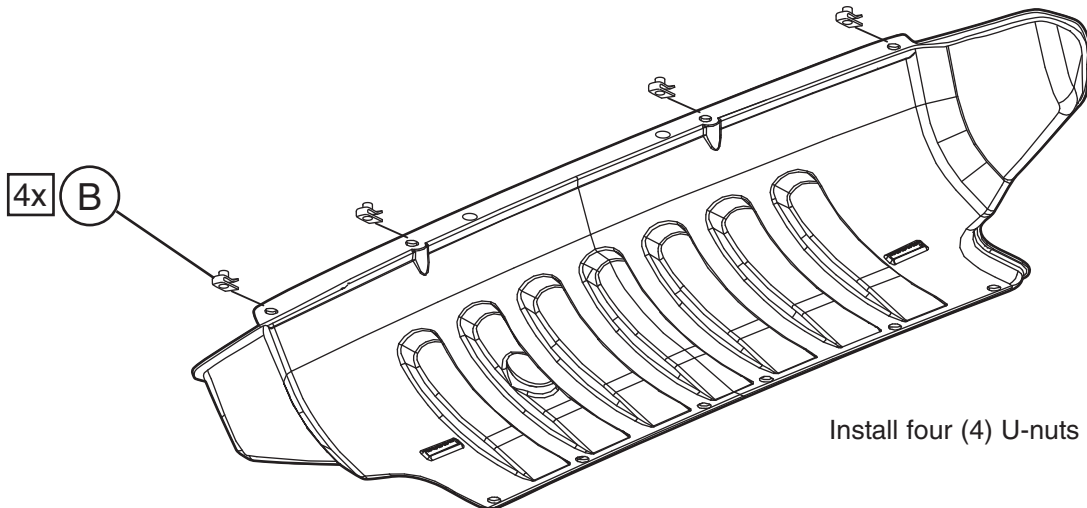

Install four (4) U-nuts (item B).

17

Kit # 82213578
(Shown)

12 N.m / 8 ft-lbs

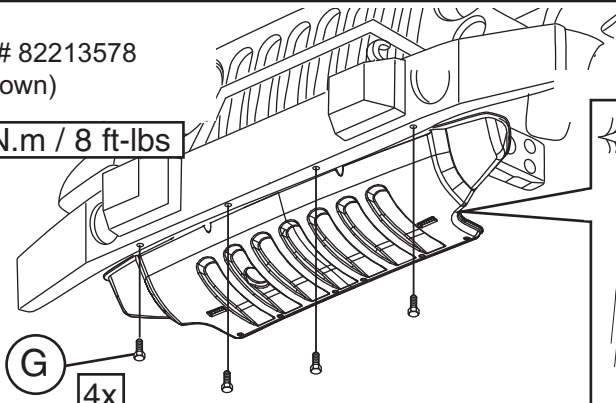

G
4x

Splashshield is designed to be positioned above rear bumper flange.

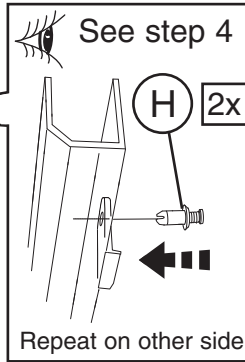

See step 4

H 2x

Repeat on other side

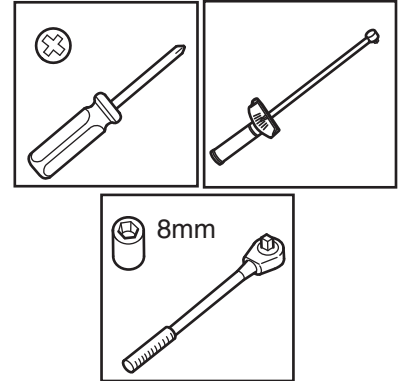

8mm

18

Kit # 82213575 (Shown)

19

See steps 1-3 Reverse Steps 3, 2 then 1 for re-installation of Grill Panel and Bumper Applique.

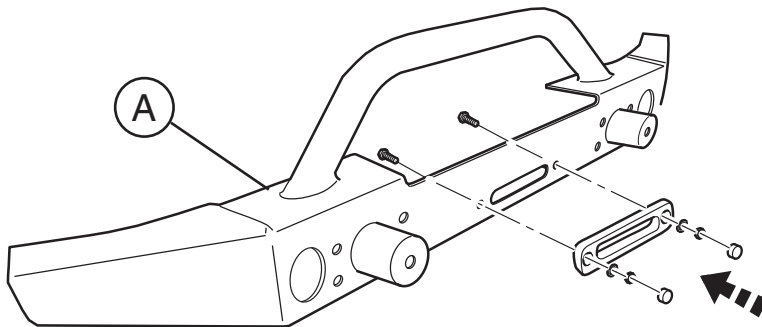

Hawse Fairlead and hardware not included in Bumper Kit .

20

Kit # 82213575 (Shown)

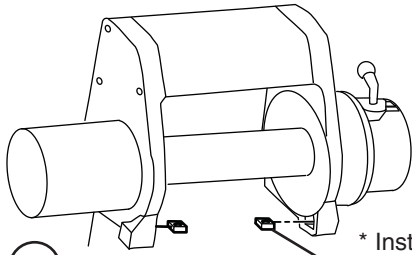

1

* Install 3/8" Square Nut (4x) *



Winch must be positioned into bumper before the bumper is attached to the vehicle.

2



A

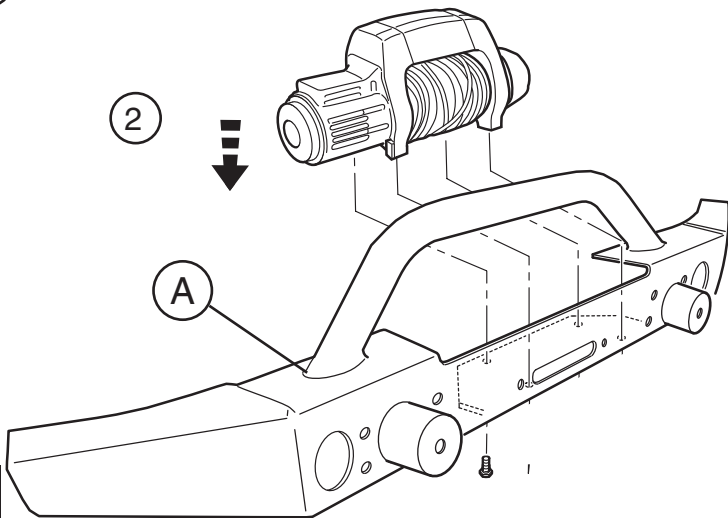

21

Note: If installing winch, rest winch in place, do not install bolts .

It will be necessary to move winch (side to side) to install bumper hardware.

Winch not included in Bumper Kit .

Note: For 2012 and newer vehicles a Vacuum relocation bracket must be used to relocate the vacuum pump from the frame to the winch plate if your installing a winch. Proceed to step 34 before moving to to step 22.

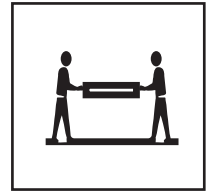

HAND TIGHTEN ONLY

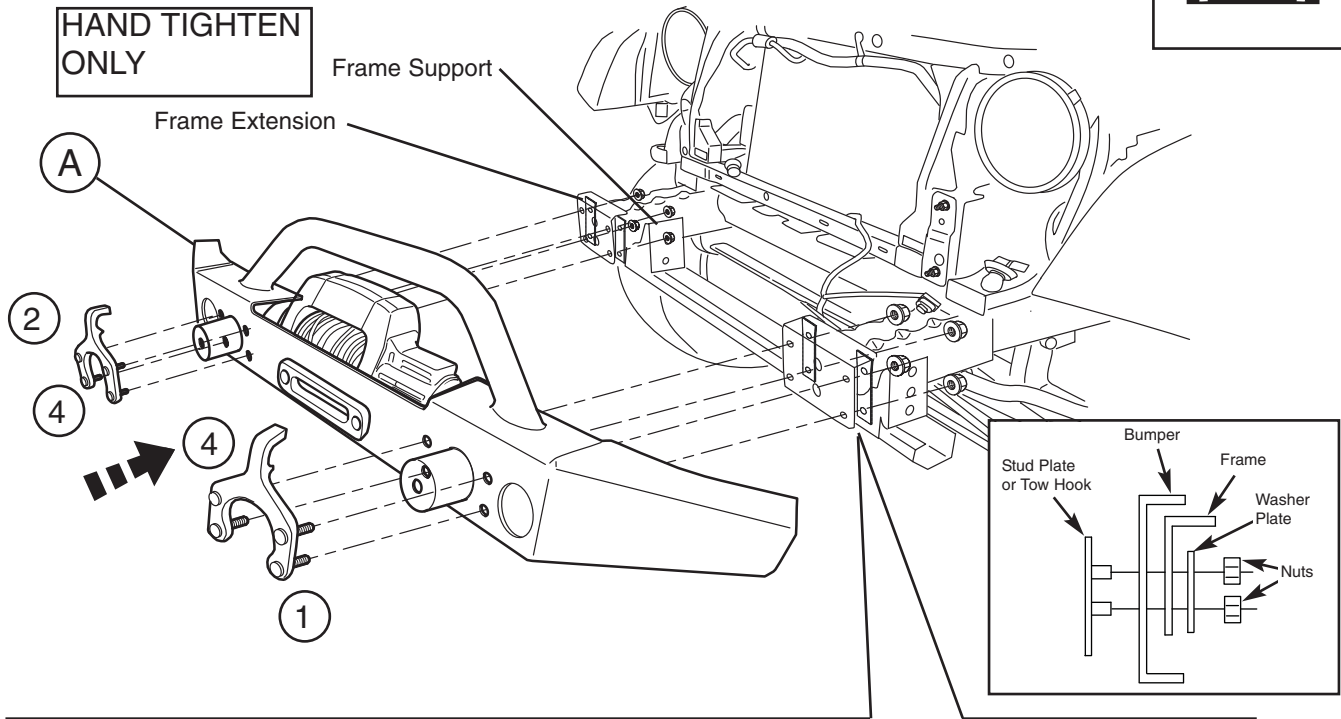

*Note: Due to vehicle variations, gaps may be present between the Lower Rear Bumper Bracket and the Frame Support. If gaps are present, install washers (item D, up to 2x per side) between the Lower Rear Bumper Bracket and the Frame Support.

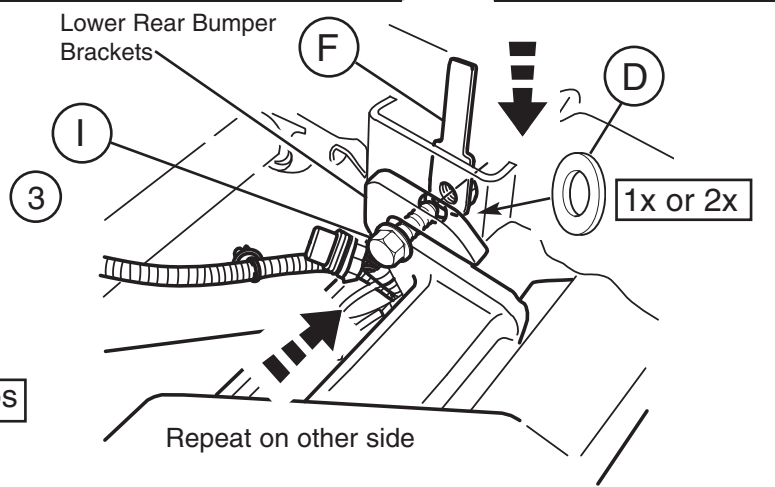

Rotate Bumper under frame extension to align lower rear bumper bracket slots to frame support hole (see frame 7) and then loosely install two tow hooks with nuts and washer plates (removed in step 5). Now loosely install bolts (item I) to handle nuts (item F). Due to vehicle variations, washers (item D) are supplied to eliminate gaps.

Vehicles without
Tow Hooks

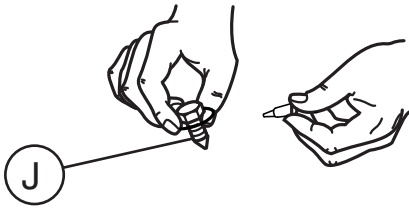

Apply Loctite to Bolts .

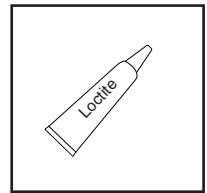

23

Vehicles without
Tow Hooks



8x 100 N.m / 75 ft-lbs

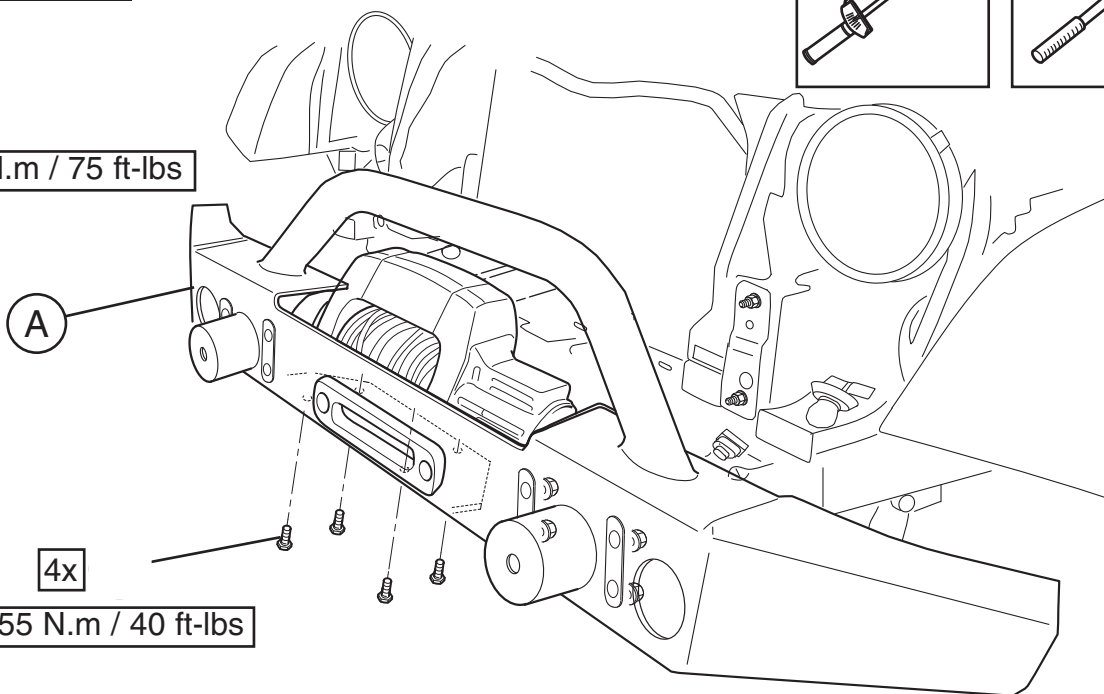

After leveling the bumper for best appearance, torque hardware as shown 8 places.

Install Winch using bolts .

Note: If bolts do not align to nuts in the winch legs, the holes in bumper may need to be enlarged slightly. If this procedure is required, deburr the holes/slots and apply Mopar Rust Inhibitor 82300508 to all bare edges and allow to dry.

Note: If you had to use the relocation bracket for 2012 and newer vehicles, re-connect the vacuum lines and electrical at this point to the Vacuum pump. There are two holes on the relocation bracket for the electrical connector. Use the push trees on the connector and reattach to the bracket.

24

Vehicles with
Tow Hooks

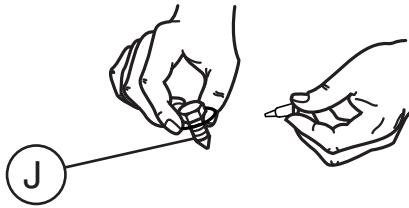

Apply Loctite to Bolts .

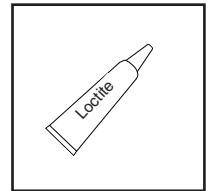

25

Vehicles with
Tow Hooks

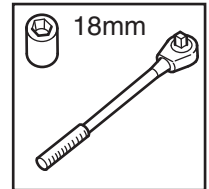
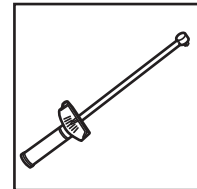

8x 100 N.m / 75 ft-lbs

A

4x
55 N.m / 40 ft-lbs

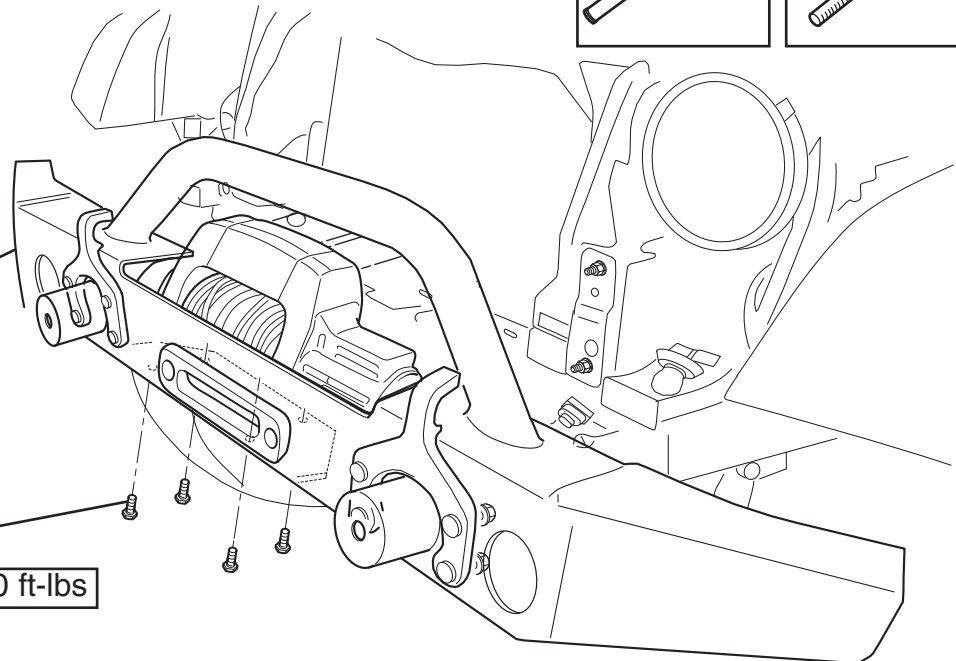

After leveling the bumper for best appearance, torque hardware as shown 8 places.

Install Winch using bolts .

Note: If bolts do not align to nuts in the winch legs, the holes in bumper may need to be enlarged slightly. If this procedure is required, deburr the holes/slots and apply Mopar Rust Inhibitor 82300508 to all bare edges and allow to dry.

Note: If you had to use the relocation bracket for 2012 and newer vehicles, re-connect the vacuum lines and electrical at this point to the Vacuum pump. There are two holes on the relocation bracket for the electrical connector. Use the push trees on the connector and reattach to the bracket.

26

C Vehicles with Tow Hooks, opening at top.

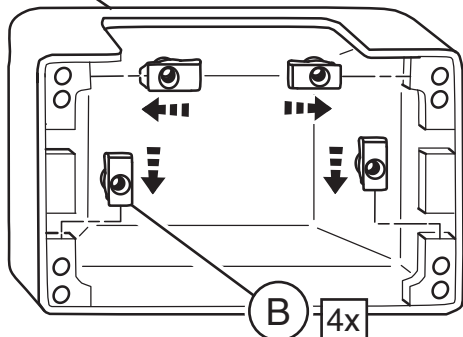

B 4x
Install U-nuts as shown, correct orientation is important for proper installation.

27

C Vehicles without Tow Hooks, opening at bottom.

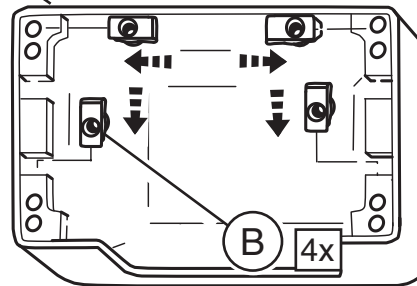

B 4x
Install U-nuts as shown, correct orientation is important for proper installation.



11 N.m / 96 in-lbs.

Do not over-torque

Repeat on other side

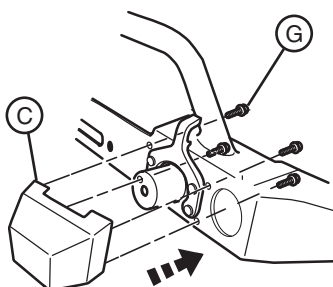

Note: View with Tow Hook

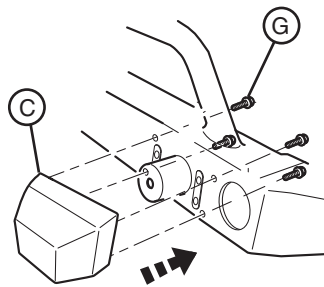

Note: View without Tow Hook

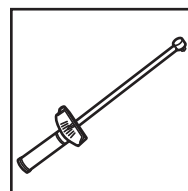
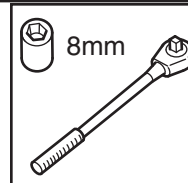

28

Modify jumper harness and connect fog lamps & wire harness

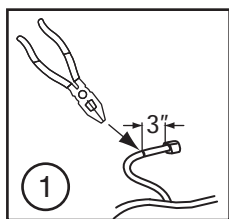
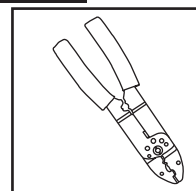
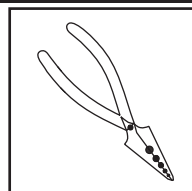
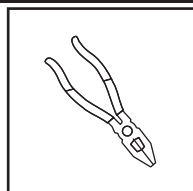
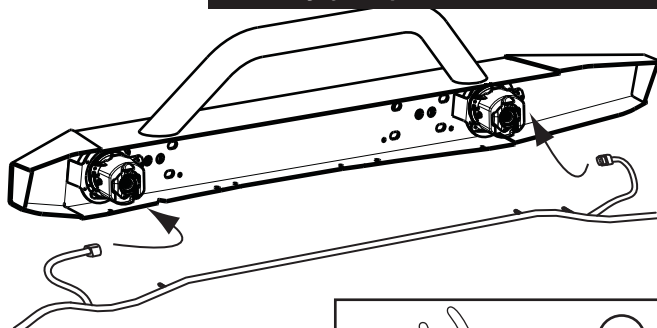

1

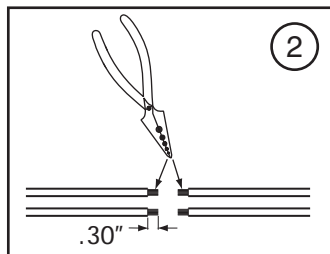

2

1) Pull back convoluted tubing near the connector. Cut the two wires 3 inches back from the connector.

2) Strip all four wire ends .30".

3) Using harness (Item O), crimp the White wire on the harness to each stripped ends of the White wire on the vehicle harness. Repeat process using the Black wire on the harness and vehicle harness.

4) Using a Heat Gun, shrink the butt connectors to the wires. Replace any convoluted tubing. Place provided convoluted tubing over the spliced wires.

5) Repeat process for other side of harness.

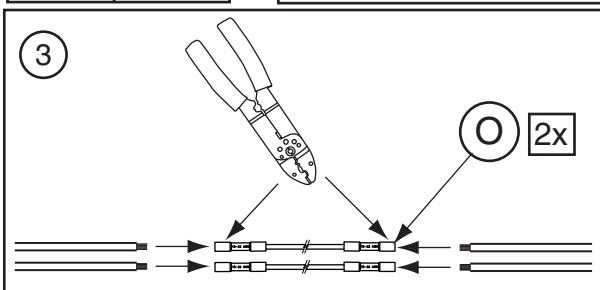

3

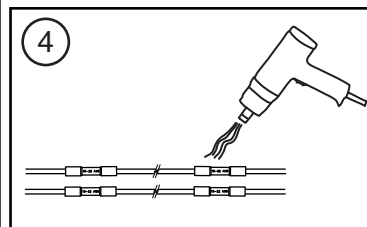

4

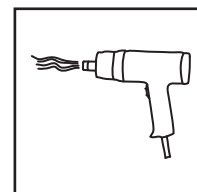

29

Kit # 82213575
(Shown)

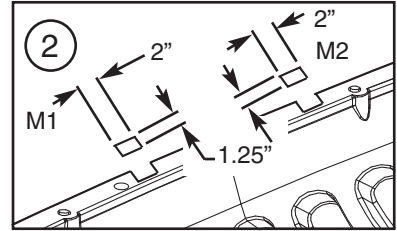
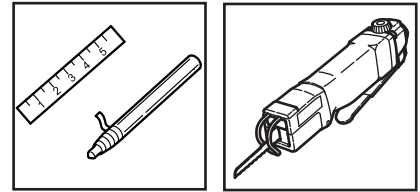
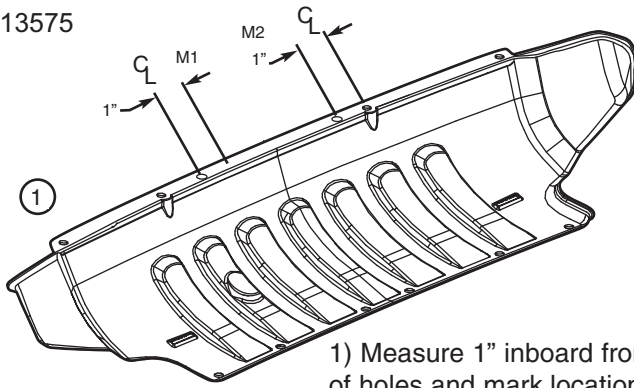

- 1) Measure 1" inboard from centerline of holes and mark locations (M1 and M2).
- 2) Notch locations 2" wide and 1.25" deep.

30

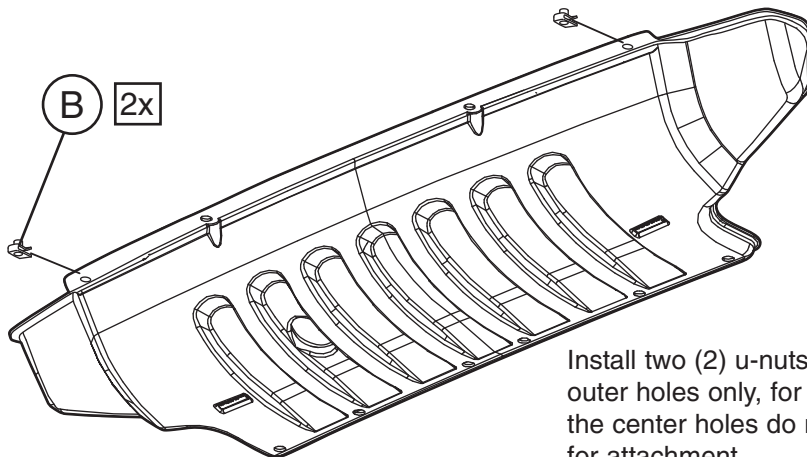

Install two (2) u-nuts (item B) to the outer holes only, for the Winch Bumper the center holes do not require u-nuts for attachment.

31

Kit # 82213575
(Shown)

12 N.m / 8 ft-lbs

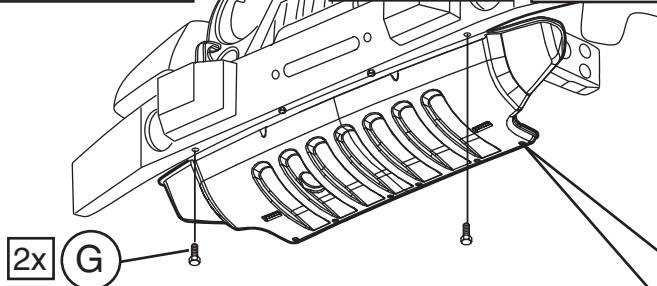
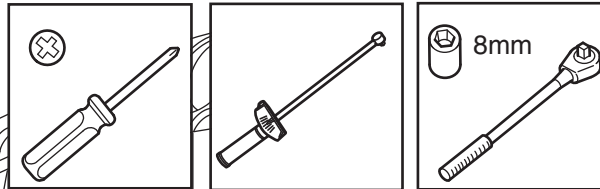

Splashshield is designed to be positioned above rear bumper flange. Outer holes (2) are used to attach splashshield.

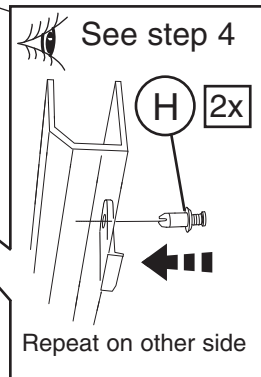

32

See steps 1-3

Reverse Steps 3, 2 then 1 for re-installation of Grill Panel and Bumper applique

33

Disconnect all hoses and electrical to Vacuum pump before removing from frame.

Remove the Vacuum pump.

Vacuum Pump that needs to be relocated onto winch plate.

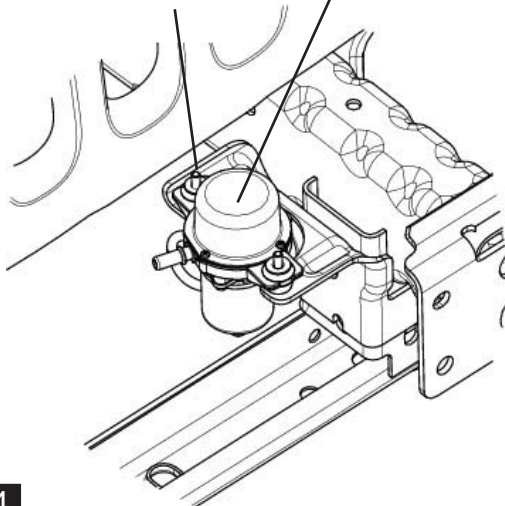

Take a marker and draw a line across the OE bracket as shown. You will need to use a Air saw or Grinder to remove this portion of the bracket.

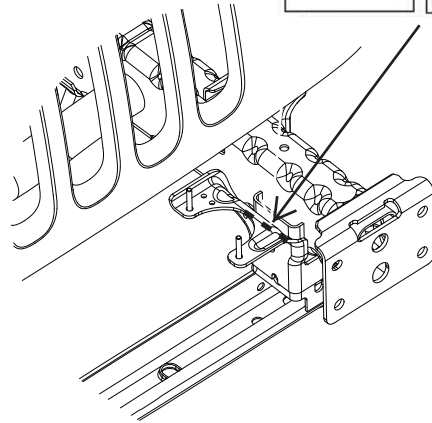
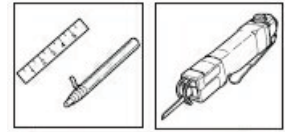

Cut along dotted line.

34

* Exploded View for Clarity

Take and install the relocation bracket to the winch plate

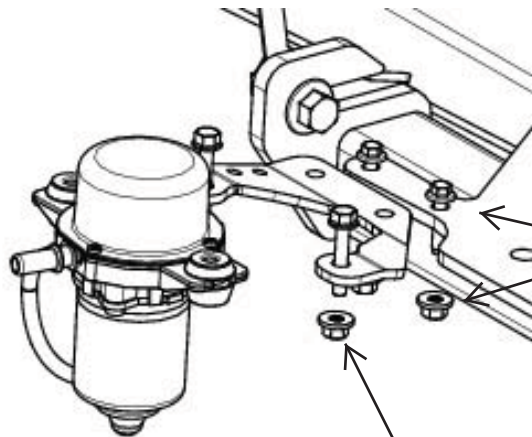

Use two M6x1.00x25mm bolts supplied and two M6x1.00 nuts supplied.



11 N.m / 96 in-lbs

Use two M6x1.00x35mm bolts supplied and two M6x1.00 nuts supplied.



11 N.m / 96 in-lbs

Once completed installing relocation bracket and pump for 2012 and newer vehicles proceed back to step 22.

35