

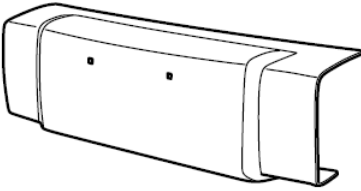





DODGE NITRO Front Fascia Applique

A 	C 2x 	
B 813mm (32") 	D 2x 	
E 2x 		

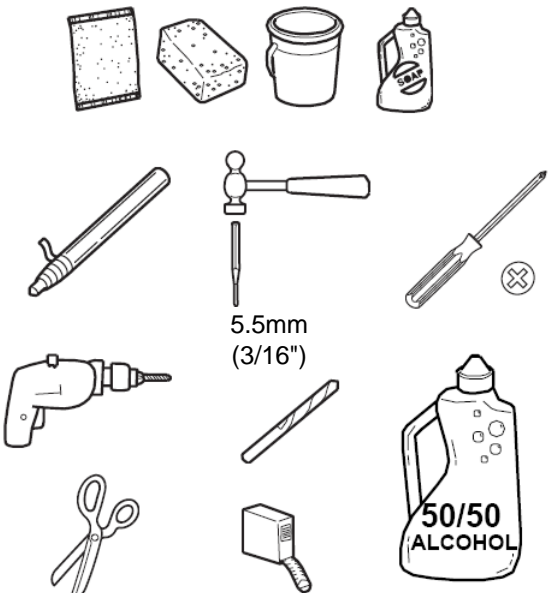
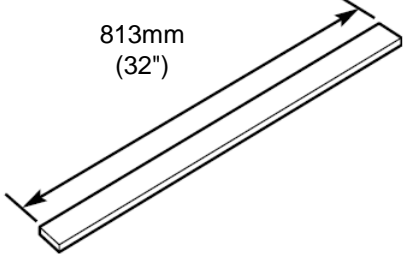

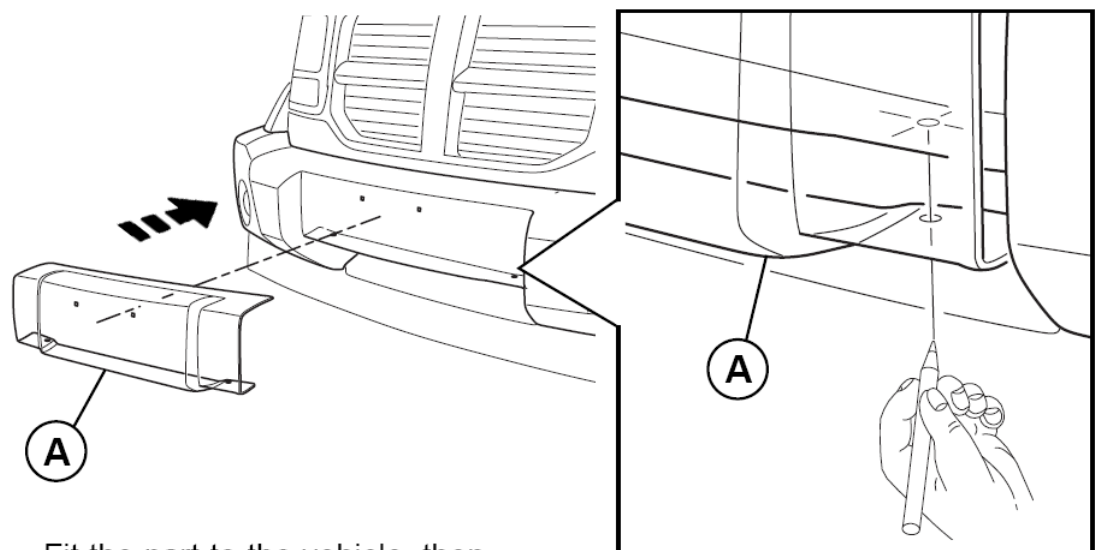
Fit the part to the vehicle, then using the part as a template, transfer the hole locations to the fascia to be drilled in step 3.

Repeat on other side.

1

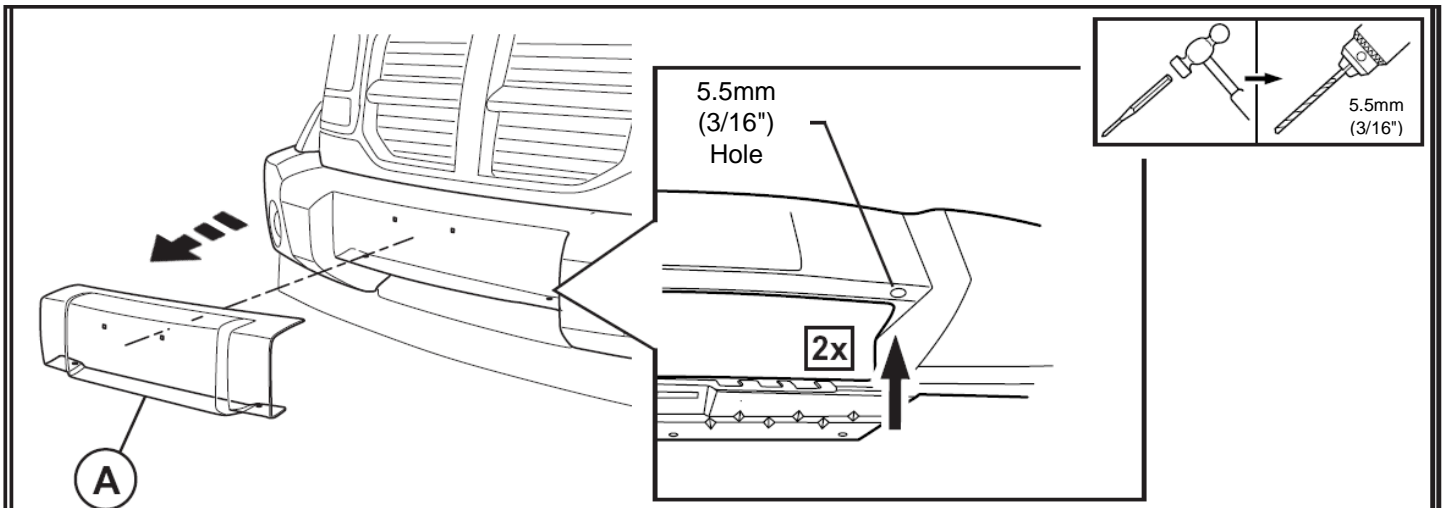

2

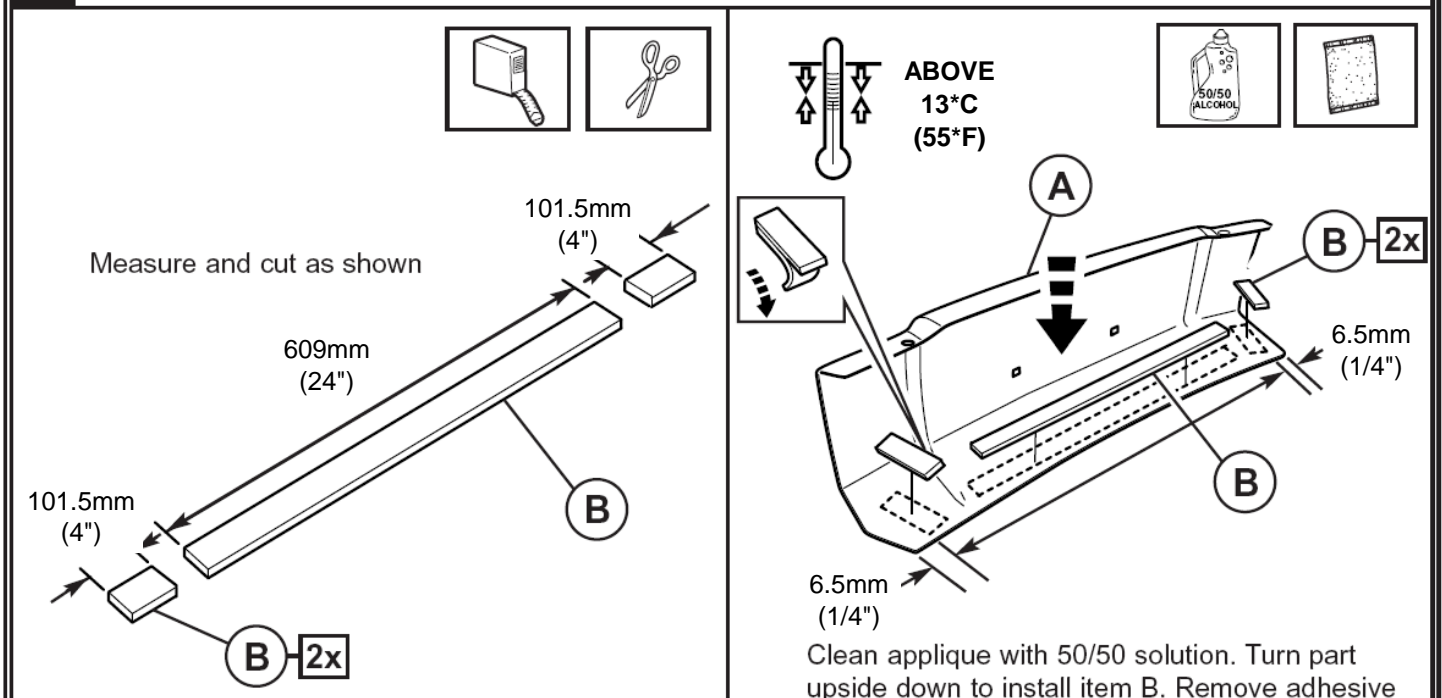

3

4

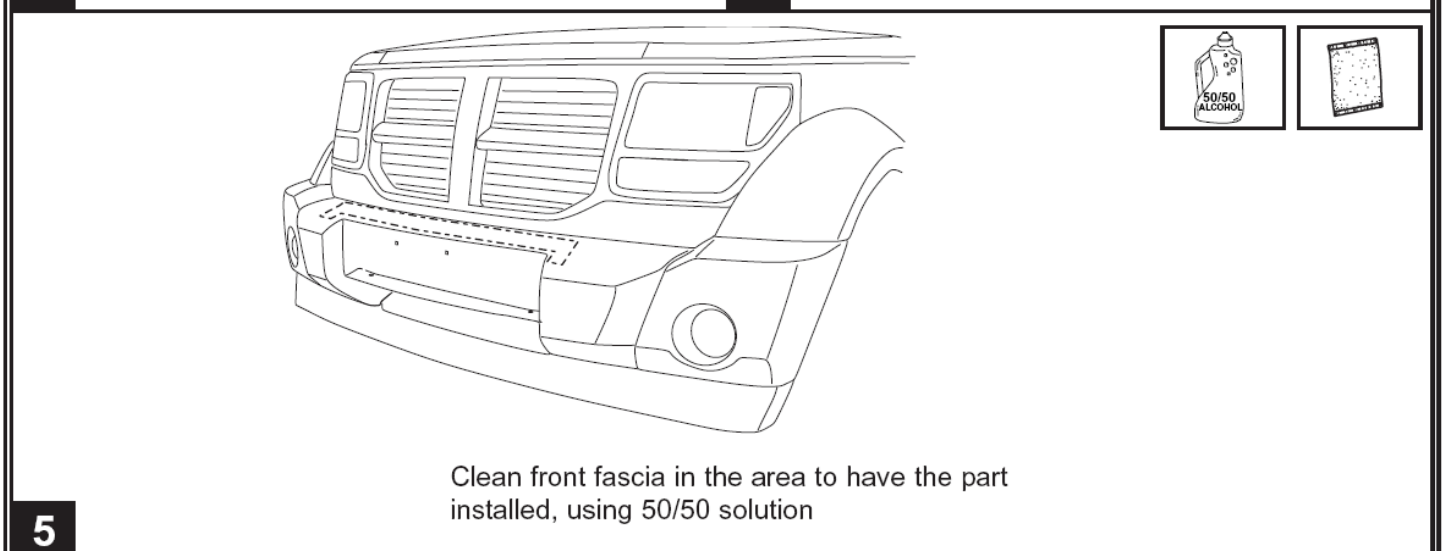

5

4

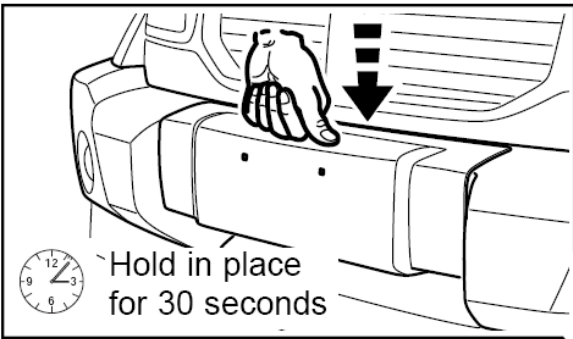

1

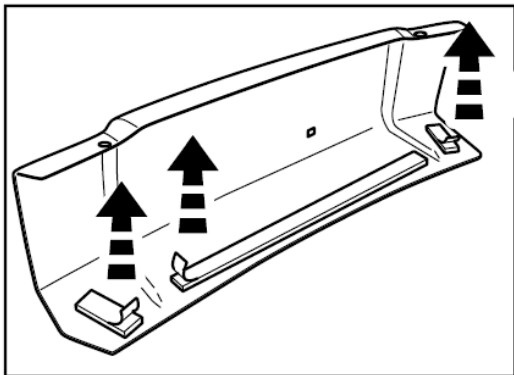

3

A

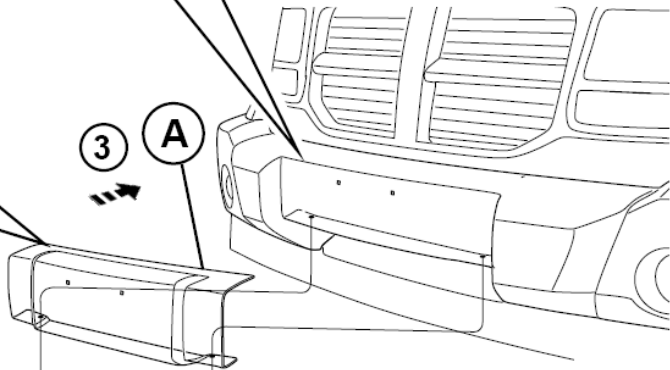

2

C 2x

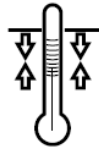

ABOVE
13°C
(55°F)

Note: 1) Remove the film from 3m adhesive fasteners. 2) Insert and hold in place the pushpin fasteners and rotate the bottom of the part to align with holes in fascia and engage then pushpins. 3) Carefully rotate part upward taking care not to allow the 3m adhesive to touch the fascia. 4) Press in place for 30 seconds when the part is rotated fully rearward.

6

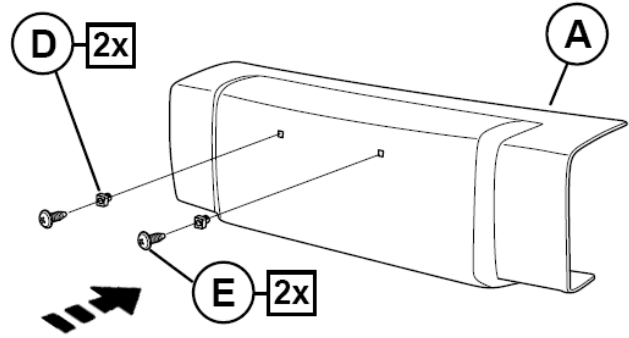

If required by state mandates for Front License Plates.

7