

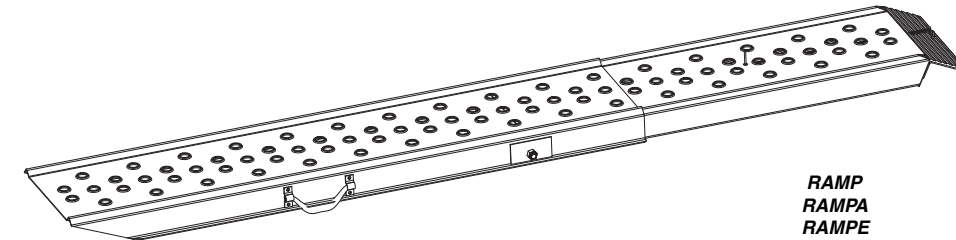

# 1000 POUND FOLDING RAMP

## Genuine Accessories



RAMP  
RAMPA  
RAMPE

A

X1

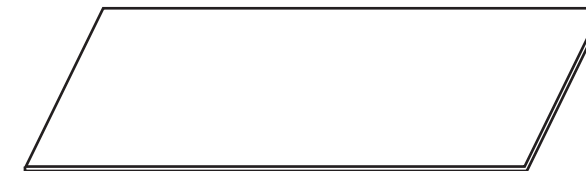

RAMP PAD  
COJÍN DE LA RAMPA  
GARNITURE DE RAMPE

B

## Tools Required / HERRAMIENTAS NECESARIAS / OUTILS NECESSAIRES



### **WARNING**

- RAMP MAY BREAK OR SLIDE IF NOT PROPERLY SECURED OR MISUSED. AVOID SLACK IN SAFETY CHAINS WHEN ATTACHING RAMPS TO THE LOADING SURFACE.
- WHEN LOADING OR UNLOADING FROM A VEHICLE, MAKE SURE EMERGENCY BRAKE IS ON, VEHICLE IS IN PARK (ENGINE OFF) WITH WHEELS BLOCKED.
- DO NOT OVERLOAD RAMPS. MAXIMUM DISTRIBUTED LOAD CAPACITY IS 1000 LBS PER RAMP. KEEP RAMPS PARALLEL AND LOAD CENTERED. DO NOT PARK LOAD ON RAMP FOR AN EXTENDED PERIOD OF TIME.
- RAMPS MUST BE CLEAN, DRY AND FREE OF GREASE, MUD, AND OTHER MATERIAL PRIOR TO USE.
- DO NOT RIDE EQUIPMENT ON RAMP. STAND TO SIDE WHEN LOADING, USE A WINCH WHEN NECESSARY AND KEEP BODY CLEAR IN CASE LOAD OR RAMPS SHIFTS/BREAKS.
- DO NOT PARK EQUIPMENT ON RAMP OR USE AS A JACK FOR CHANGING OIL, OR VEHICLE MAINTENANCE.
- NOT INTENDED FOR LOADING AUTOMOBILES, TRUCKS, PERSONS OR AS A HANDICAP ACCESS.
- DO NOT ALTER RAMPS OR USE OTHER THAN INDICATED IN THESE WARNINGS AND ACCOMPANYING INSTRUCTIONS. USE ONLY ON FIRM, LEVEL SURFACE.
- NOT INTENDED FOR USE ON TRAILERS. LOADING SURFACE MUST BE BETWEEN 28" AND 40" OFF THE GROUND. RAMP MUST BE SECURED TO THE LOADING SURFACE.

I-10449

© DAIMLERCHRYSLER



# 1000 POUND FOLDING RAMP

Genuine Accessories

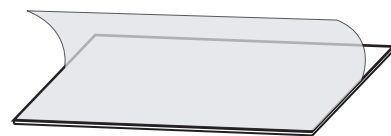
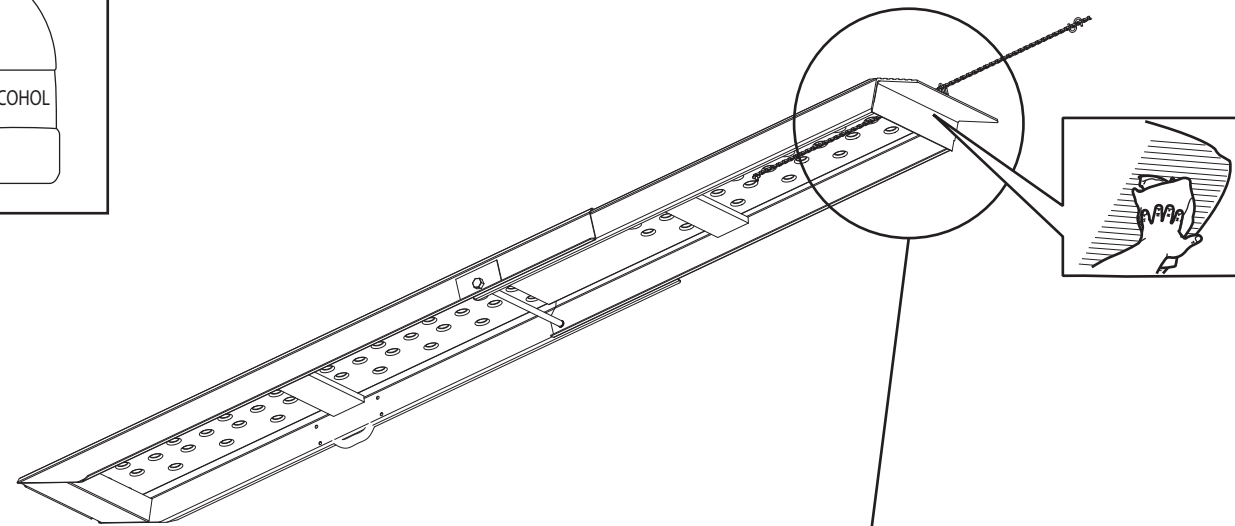

B

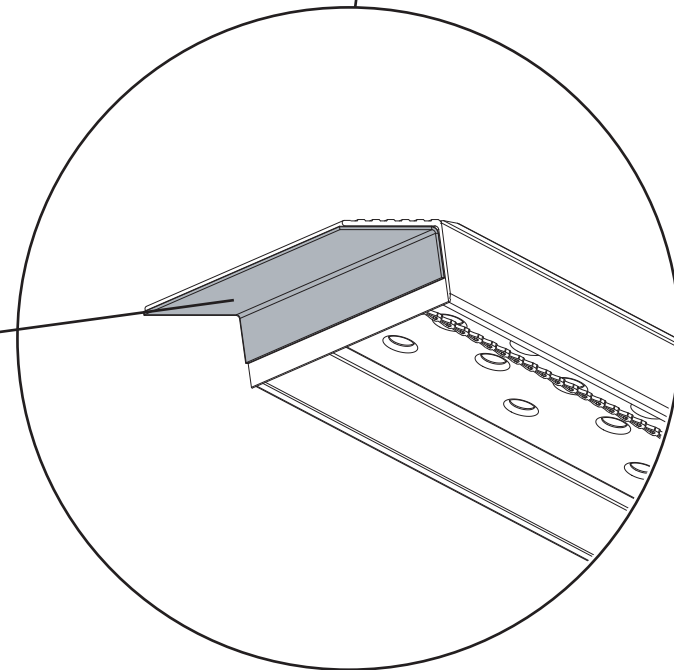

1



# 1000 POUND FOLDING RAMP

Genuine Accessories

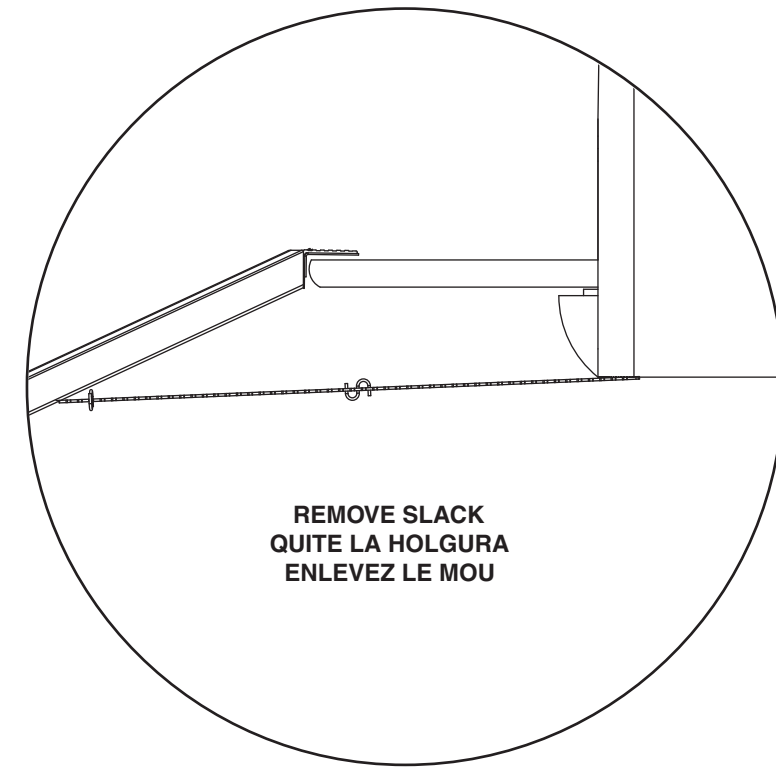
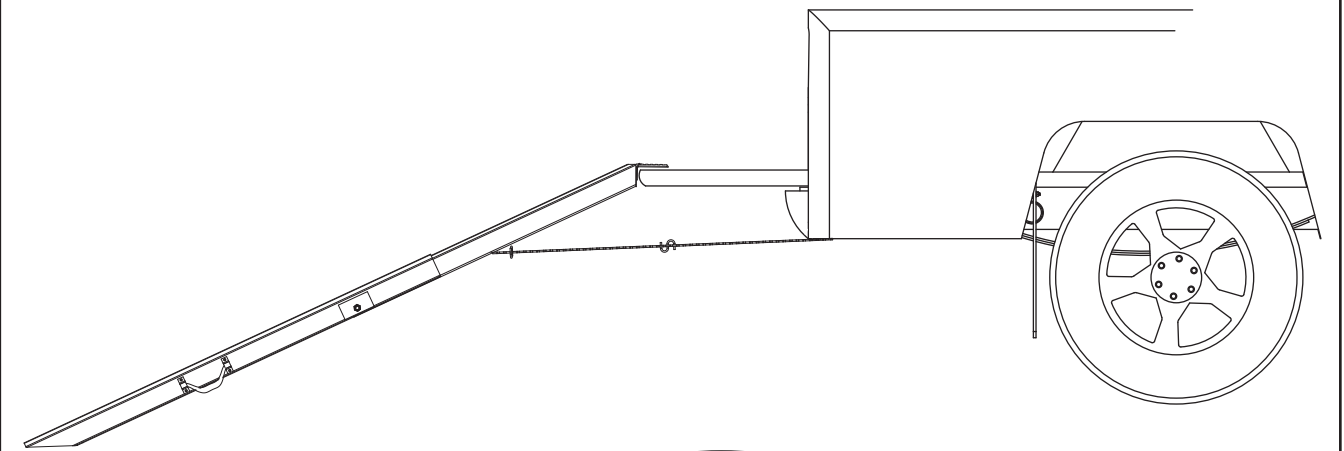

REMOVE SLACK  
QUITTE LA HOLGURA  
ENLEVEZ LE MOU

2