

CHALLENGER MOPAR STRIPE KIT

- KIT # 82212430 Mopar Blue Stripes (JBM)
- KIT # 82212431 Silver Metallic Stripes (CA1)
- KIT # 82212432 Flame Red Stripes (PR4)



GRAPHIC APPLICATION INSTRUCTIONS

Note:

- Wash hands prior to installation or use alcohol wipe.
- Vehicle and decal temperature should be between 70° F and 90° F.
- Leave vehicle in warm facility for 5 hours after application.
- DO NOT wash car for 5 days after installation.
- DO NOT apply in direct sunlight.
- Apply in a dust-free environment.
- Use a generous amount of solution.

Soap/Water Solution:

In a spray atomizer, mix the following:

- 5 ml (1 tsp) liquid soap, (lanolin-free)
- 1 litre (1 qt) of water



TOOLS REQUIRED

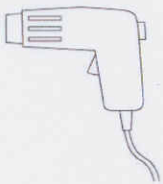

Heat Gun
(If needed)

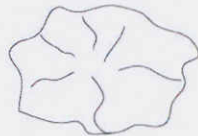

Clean Lint-Free
Cloth



Pin

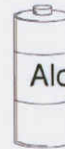

100%
Isopropyl
Alcohol

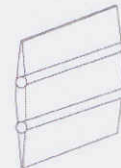

Squeegee



Spray
Bottle

CHALLENGER MOPAR DECAL INSTRUCTIONS

- 1. DEFECT REMOVAL :** Remove any dirt nibs or defects in the paint that would result in objectionable read-through defects after decal is applied.
- 2. BODY SURFACE:** Body surface temperature must be a minimum of 70°F during decal application to ensure conformability and initial adhesive bond.
- 3. ALCOHOL WIPE:** Wipe the body surface to which the decals will be applied with a clean, lint-free cloth moistened with isopropyl alcohol to remove contaminants.
- 4. DRY WIPE:** Wipe the same body surfaces as in step 3 with a clean, dry lint-free cloth to remove remaining haze.
- 5. DOOR DECAL LINER REMOVAL:** Lay decal paper liner side up on flat, clean surface. Slowly remove paper liner in a 180° direction, keeping part as flat as possible. Avoid finger contact with decal adhesive surface. Spray exposed adhesive and the door surface with the wetting solution.

INSTALL DOOR DECAL FIRST

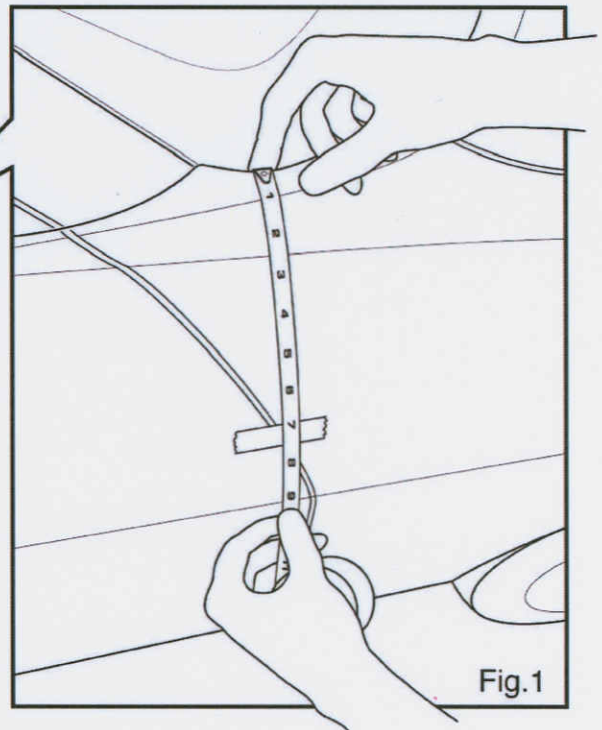
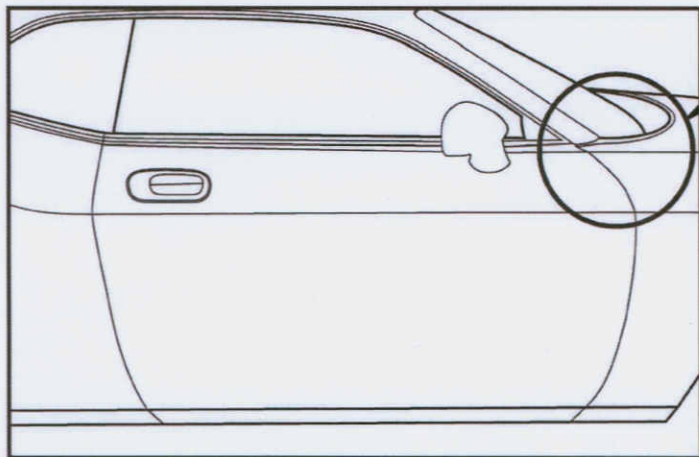

Fig.1

6. DOOR DECAL POSITIONING: With a flexible measuring tape, measure from top of fender and place a piece of masking tape 7.5 in. down, (Fig.1). Hold the premask area of the part and position to body using paper premask locators. First locate the premask to the door handle opening. Then locate upper edge of premask to the masking tape near the front of the door, (Fig.2). Do not pre-adhere decal to vehicle with hands. Keep decal as flat as possible. Do not allow the adhesive surface to become contaminated by touching clothing or floor, etc. **If the decal does not float into position**, add one to two more drops of liquid dish soap to the wetting solution and spray adhesive side again. Once decal is in position, spray the premask with the wetting solution. This will allow the squeegee to glide over the premask easier.

7. SQUEEGEE: Squeegee entire decal with a plastic squeegee. Start at the center and fan out to the edges using firm, overlapping strokes. Take extra care working the edge of the squeegee around the mirror seal.

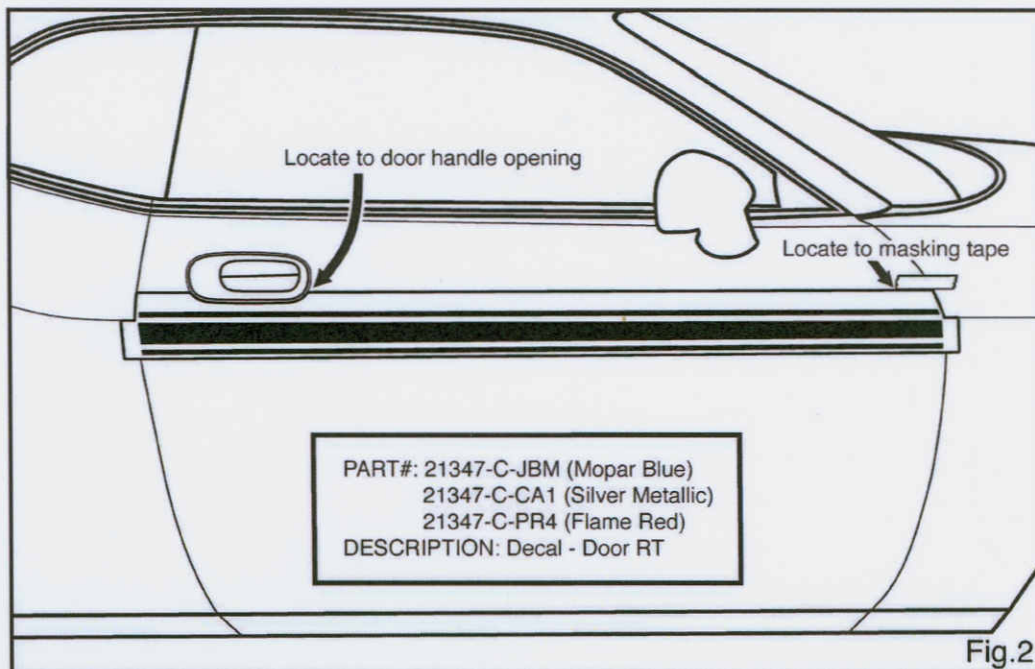
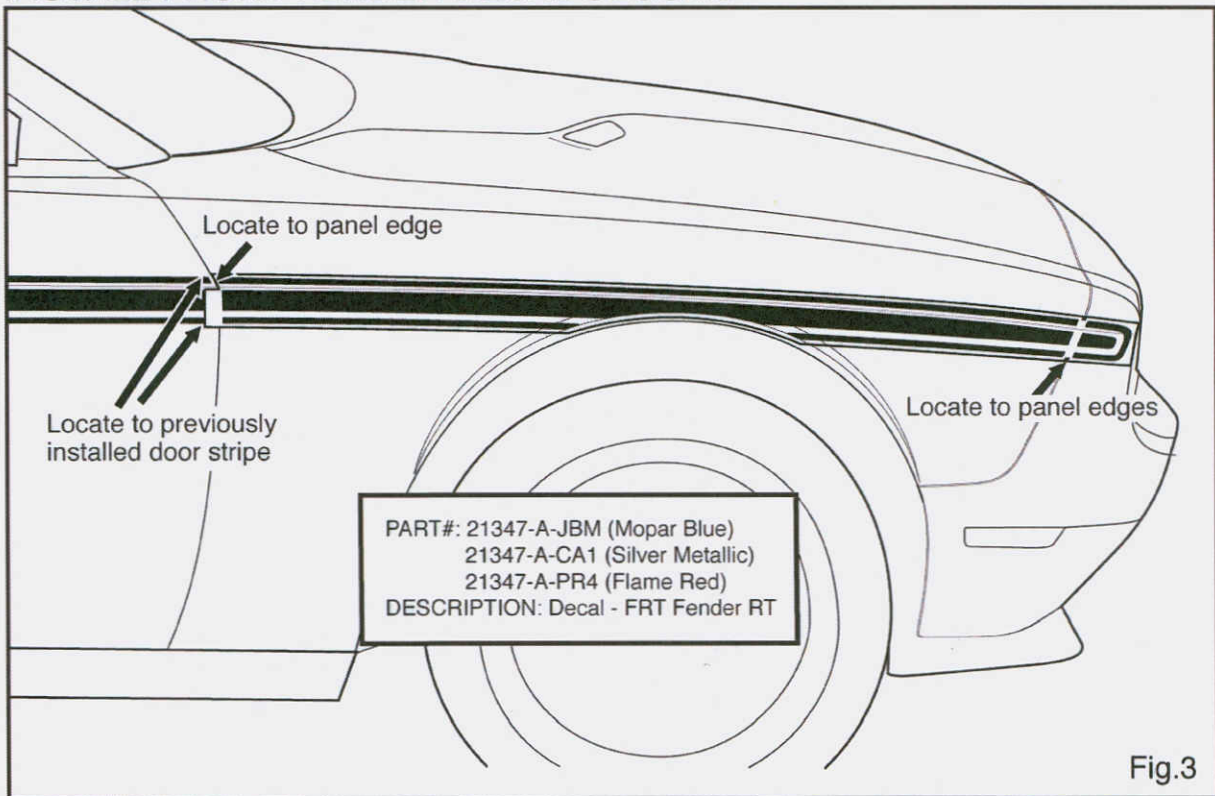

Fig.2

8. **PREMASK REMOVAL:** Slowly remove the premask in a 180° direction, (flat to surface). Do not snap it off or remove in a 90° direction, (perpendicular to the surface). Take extra care in the thin pointed areas. **If the decal comes up while removing the paper premask**, there may be too much soap in the wetting solution or the temperature may be below 70°F. Re-squeegee the entire decal, then wait a few minutes to allow the adhesion of the decal to increase before removing premask.
9. **RE-SQUEEGEE:** Squeegeeing after premask removal may be necessary in certain areas. Work bubbles out to the nearest edge or use air release tool or pin and re-squeegee that area to ensure proper adhesion.
10. **INSPECTION:** Dry off vehicle and inspect for any remaining bubbles.
11. **POST APPLICATION:** Allow the vehicle to remain 70°F for at least fifteen minutes before taking outside in freezing conditions. Do not power wash decal area for 72 hours.

INSTALL FRONT FENDER DECAL SECOND



12. **FRONT FENDER DECAL LINER REMOVAL:** Lay decal paper liner side up on flat, clean surface. Slowly remove paper liner in a 180° direction, keeping part as flat as possible. Avoid finger contact with decal adhesive surface. Spray exposed adhesive and the door surface with the wetting solution.
13. **FRONT FENDER DECAL POSITIONING:** Hold the premask area of the part and position to body using paper premask locators. First locate the feature in the premask to the previously installed door stripe and the panel edge, (Fig.3). Then locate front of premask to fender / fascia panel edges. Do not pre-adhere decal to vehicle with hands. Keep decal as flat as possible. Do not allow the adhesive surface to become contaminated by touching clothing or floor, etc. **If the decal does not float into position**, add one to two more drops of liquid dish soap to the wetting solution and spray adhesive side again. Once decal is in position, spray the premask with the wetting solution. This will allow the squeegee to glide over the premask easier.
14. **FOLLOW STEPS 7 THRU 11.**

INSTALL REAR FENDER DECAL THIRD

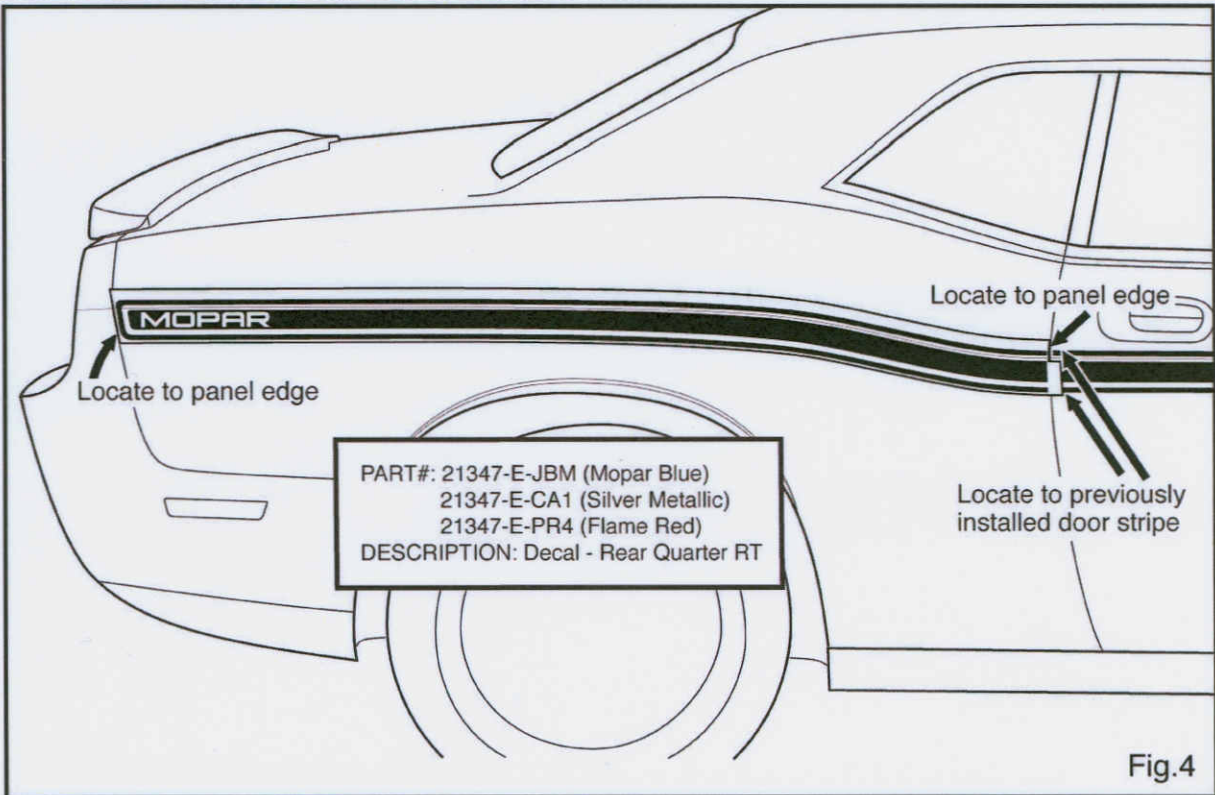

16. REAR FENDER DECAL LINER REMOVAL: Lay decal paper liner side up on flat, clean surface. Slowly remove paper liner in a 180° direction, keeping part as flat as possible. Avoid finger contact with decal adhesive surface. Spray exposed adhesive and the door surface with the wetting solution.

17. REAR FENDER DECAL POSITIONING: Hold the premask area of the part and position to body using paper premask locators. First locate the feature in the premask to the previously installed door stripe and the panel edge, (Fig.4). Then locate rear of premask to rear fender panel edge. Do not pre-adhere decal to vehicle with hands. Keep decal as flat as possible. Do not allow the adhesive surface to become contaminated by touching clothing or floor, etc. **If the decal does not float into position**, add one to two more drops of liquid dish soap to the wetting solution and spray adhesive side again. Once decal is in position, spray the premask with the wetting solution. This will allow the squeegee to glide over the premask easier.

18. FOLLOW STEPS 7 THRU 11.

19. REPEAT ON OTHER SIDE OF THE VEHICLE.