

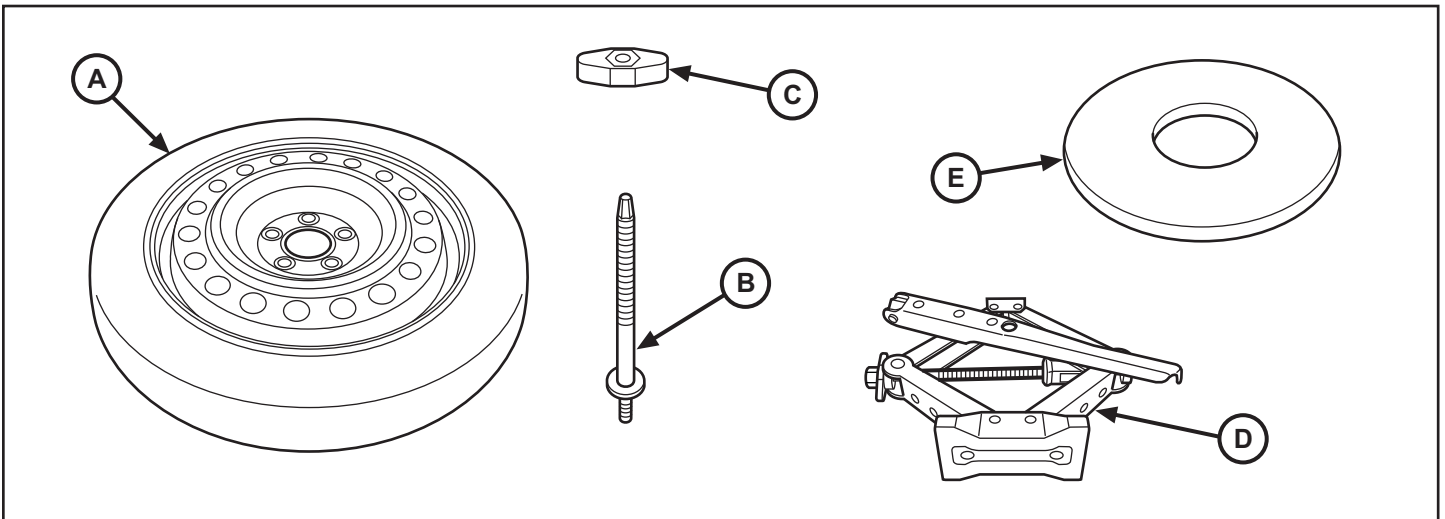

# Spare Tire

DODGE DART



CALL OUT	DESCRIPTION	QUANTITY
A	Spare Tire	1
B	Mounting shaft	1
C	Wing Nut	1
D	Jack Assembly	1
E	Cover Disk	1

TOOLS REQUIRED	
5.5mm Socket	Torque Wrench

## SPARE TIRE

1. Mounting locations shown.

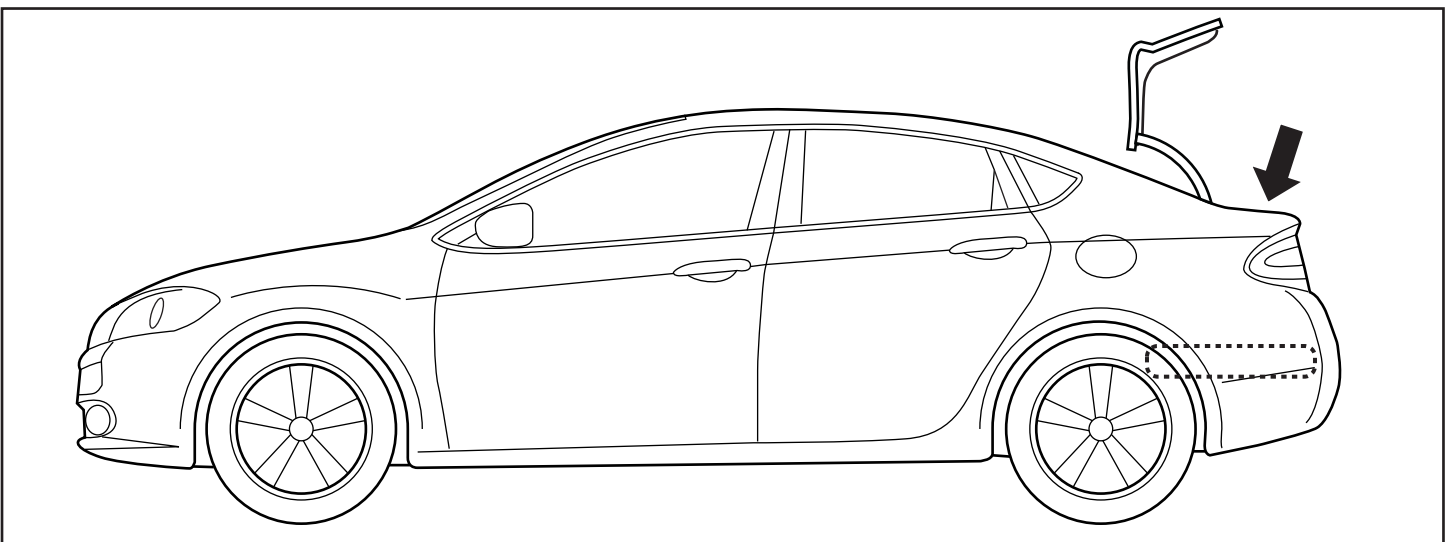

2. Open the trunk. Remove the floor access panel.

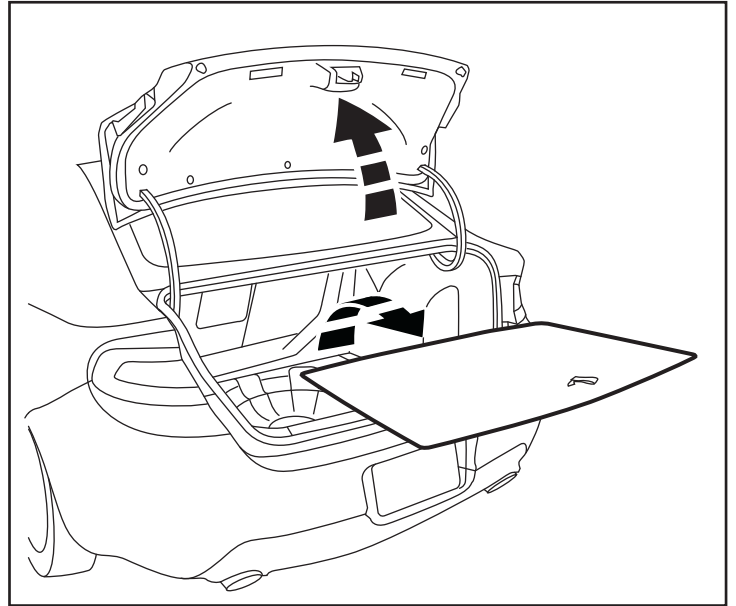

3. Thread the mounting shaft into the center base bracket. Using a 5.5mm socket and torque wrench, tighten shaft to 35 Nm (26 ft. lbs.).

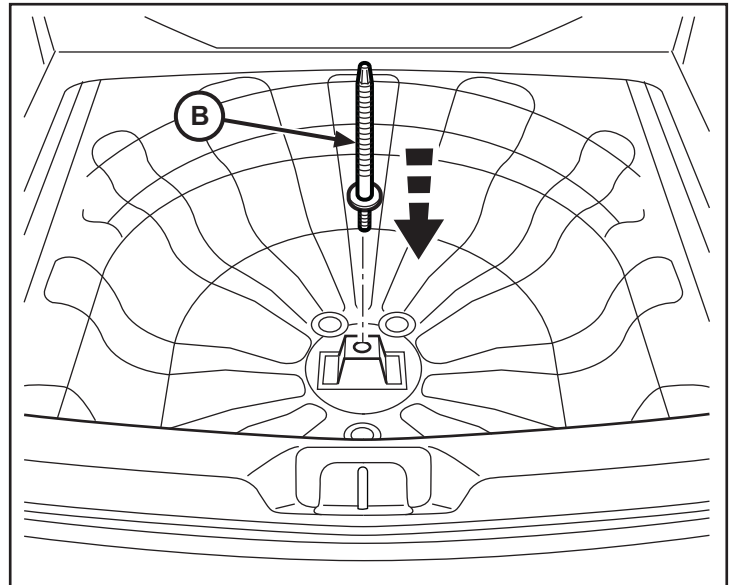

4. Place the spare tire into the trunk cavity making sure the mounting shaft comes up through the center of the tire.

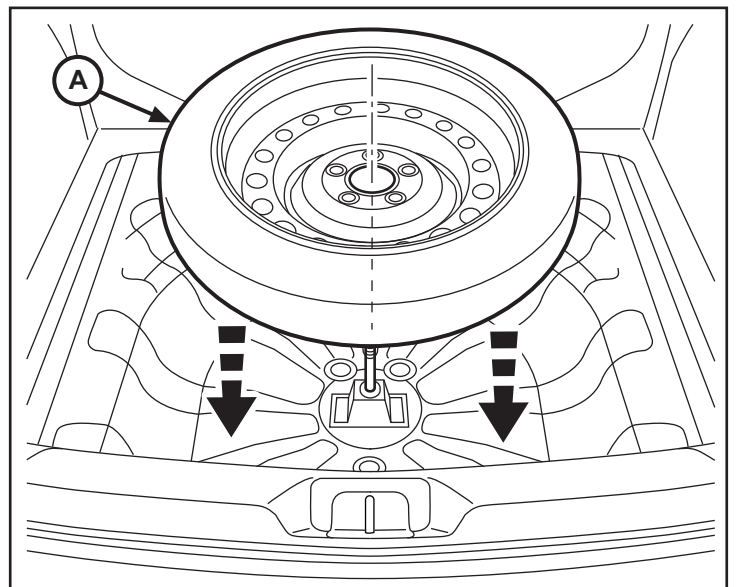

5. Carefully slide the jack assembly down over the mounting shaft and into the spare tire. Be sure the mounting shaft comes up through the center hole in the jack handle.

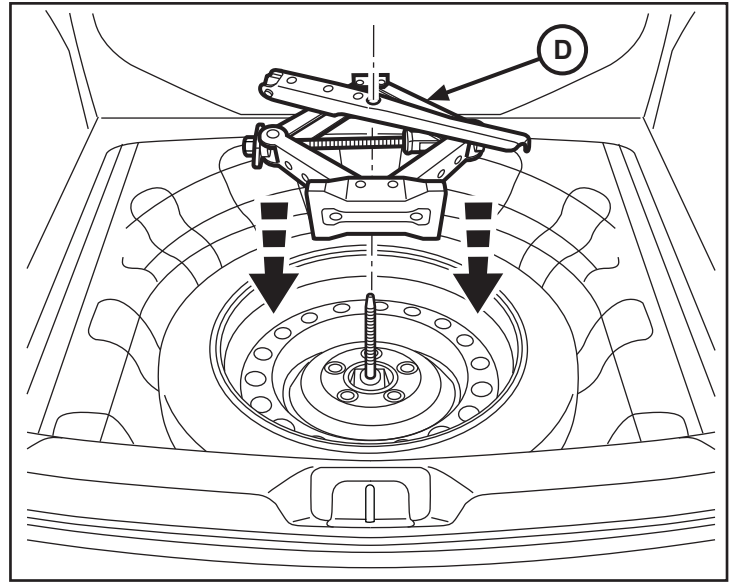

6. Place the protective cover disk into position over the jack.

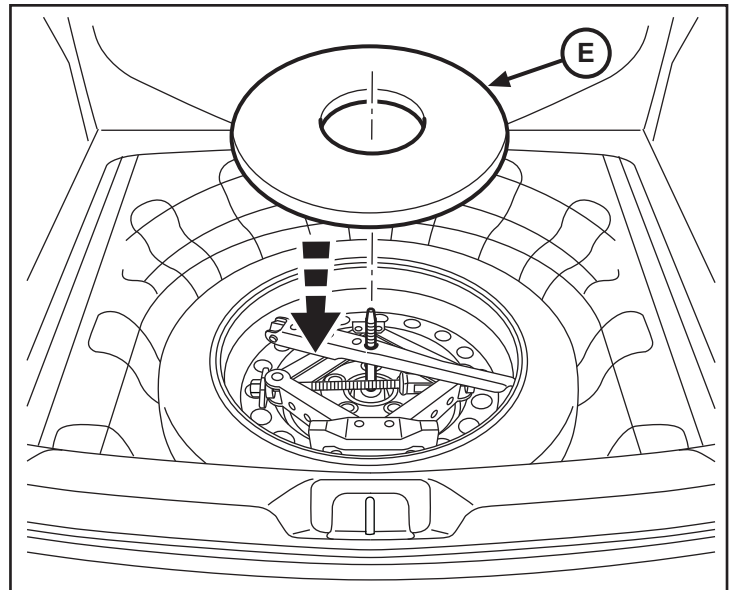

7. Firmly secure the spare tire and jack assembly with the wing nut. Do not over tighten.

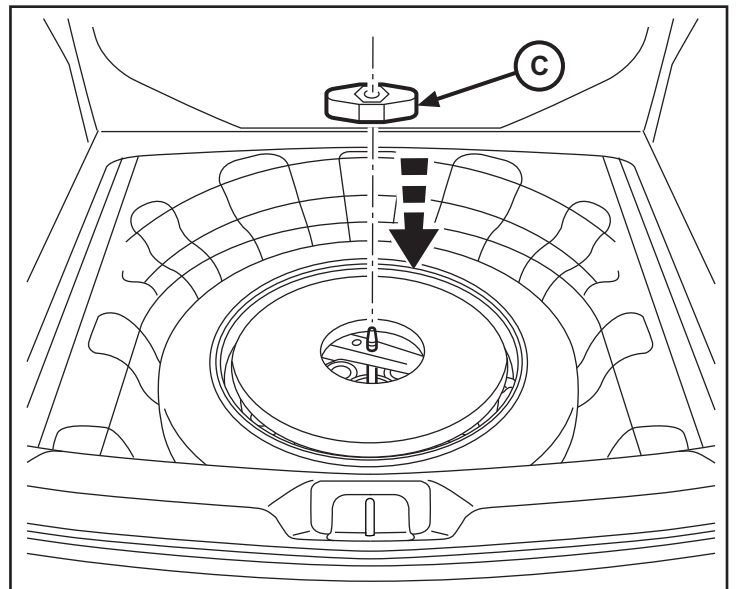

8. Reinstall the floor access panel inside the trunk.



# Pneu de rechange

DODGE DART

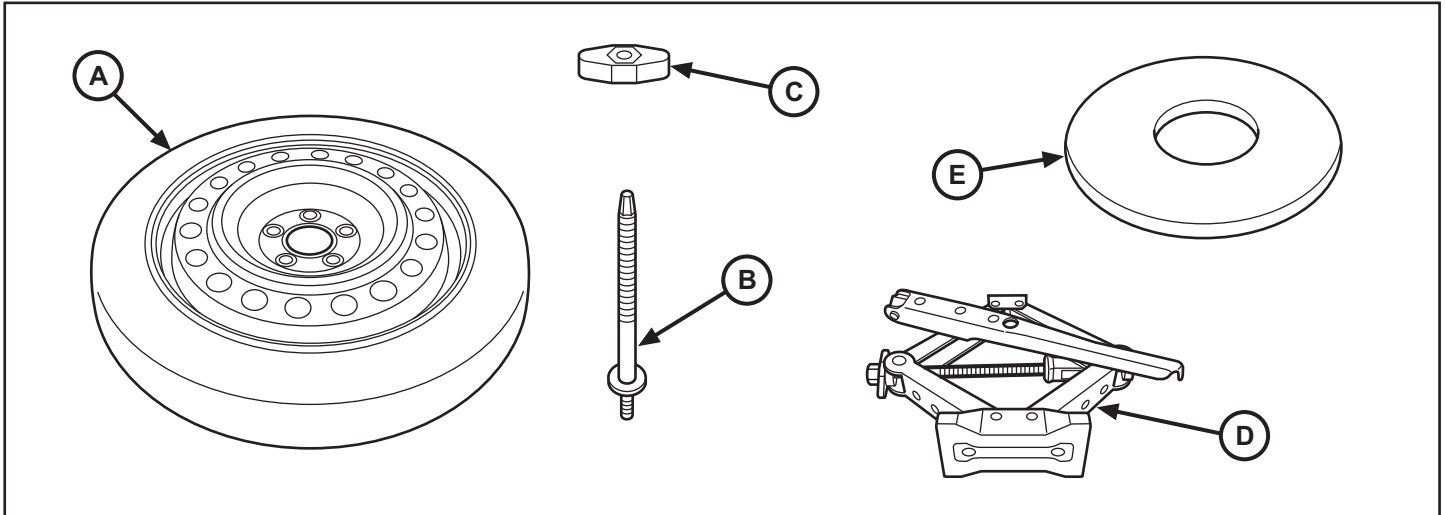

RÉFÉRENCE	DESCRIPTION	QUANTITÉ
A	Pneu de rechange	1
B	Tige de montage	1
C	Écrou à oreillettes	1
D	Ensemble de cric	1
E	Couvercle	1

OUTILS REQUIS	
Douille de 5,5 mm	Clé dynamométrique

## Pneu de rechange

1. Emplacement de montage indiqué.

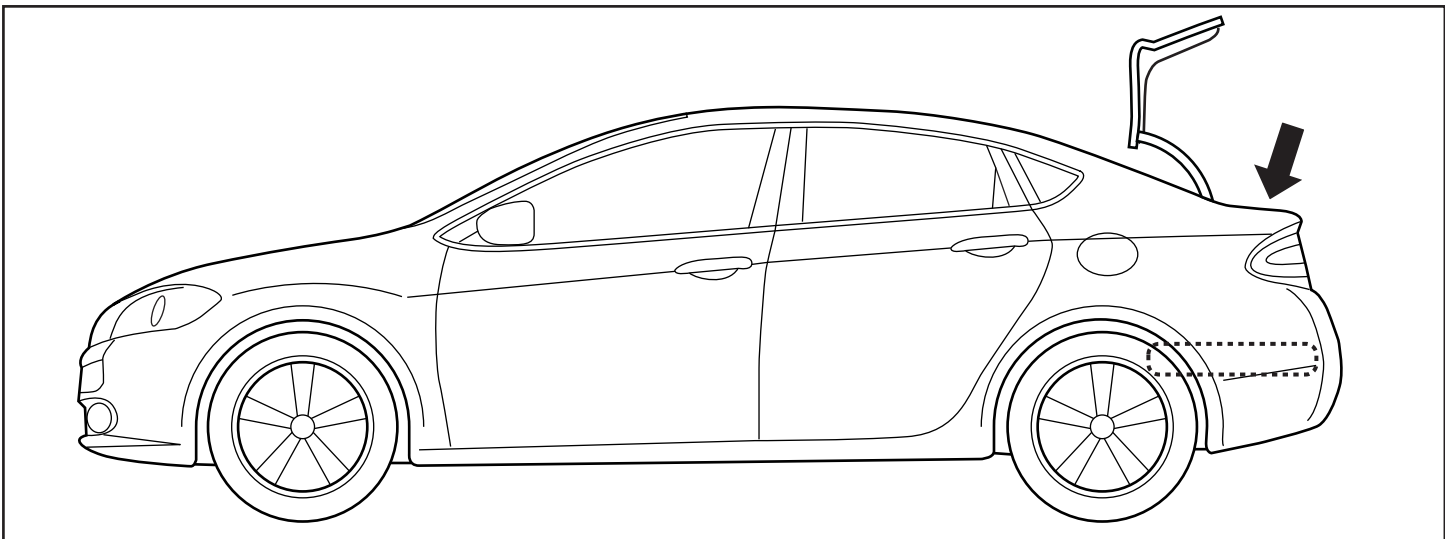

2. Ouvrez le coffre arrière. Déposez le panneau d'accès à la cavité sous le plancher.

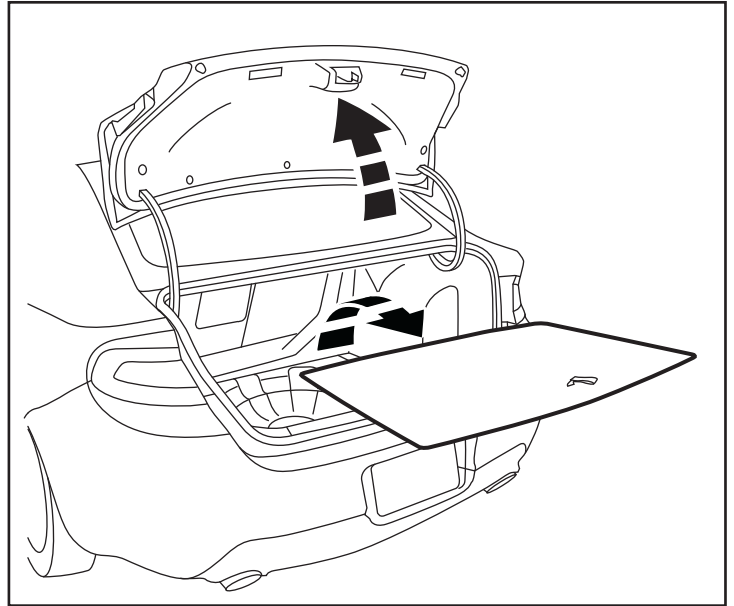

3. Vissez la tige de montage dans le support de la base centrale. À l'aide d'une douille de 5,5 mm et d'une clé dynamométrique, serrez la tige à un couple de 35 Nm (26 lb-pi).

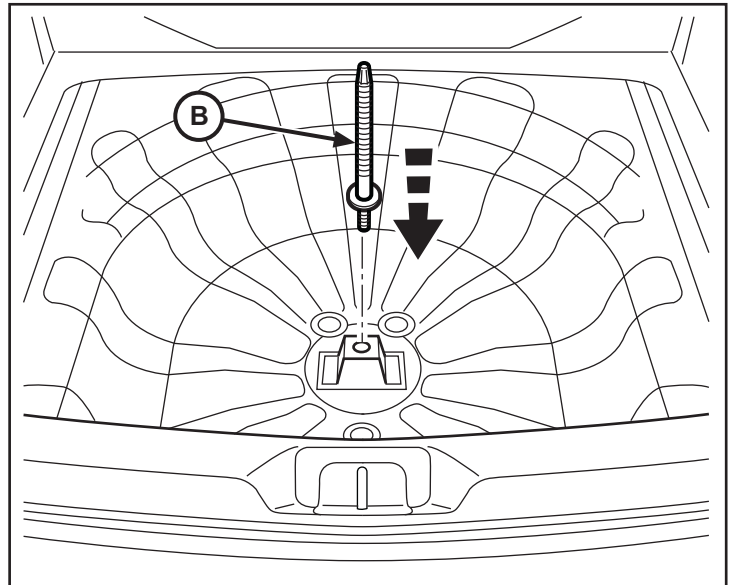

4. Placez le pneu de rechange dans la cavité en vous assurant de faire passer la tige de montage dans le centre de la jante.

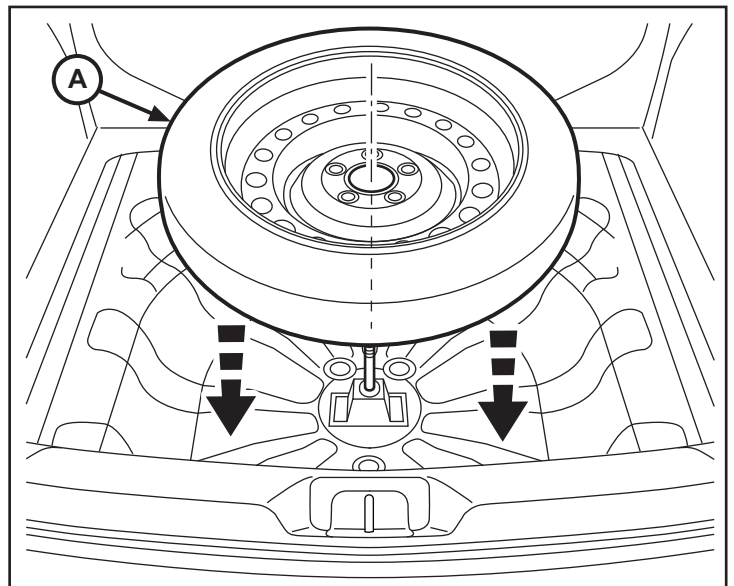

5. Insérez lentement le cric sur la tige de montage et dans la jante du pneu de rechange. Assurez-vous que la tige sort du trou central de la poignée du cric.

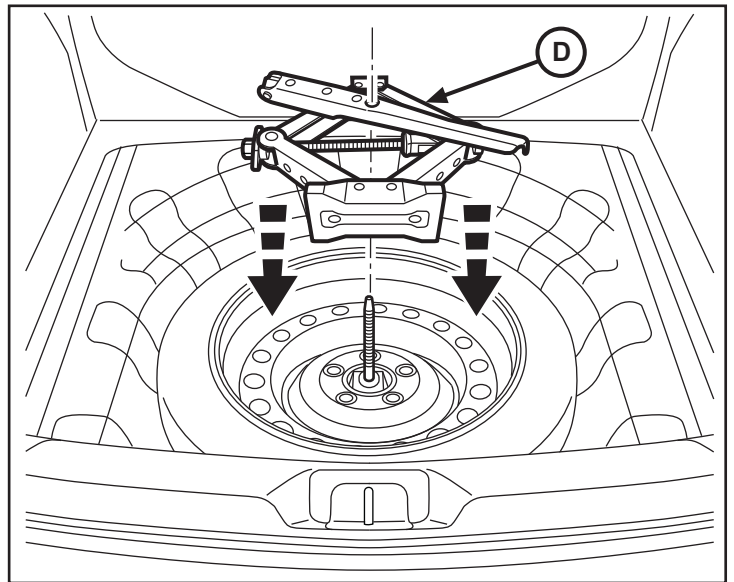

6. Placez le couvercle protecteur sur le cric.

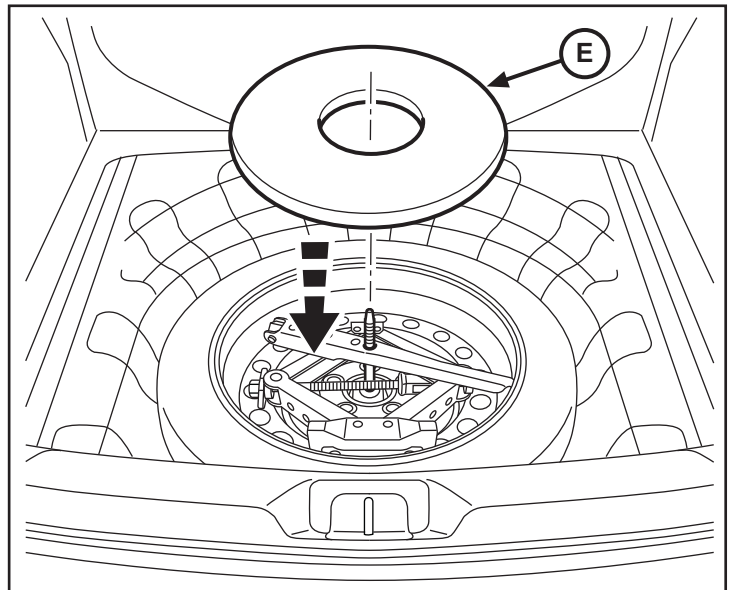

7. Serrez fermement l'assemblage pneu de rechange et cric à l'aide de l'écrou à oreillettes. Ne pas serrer outre mesure.

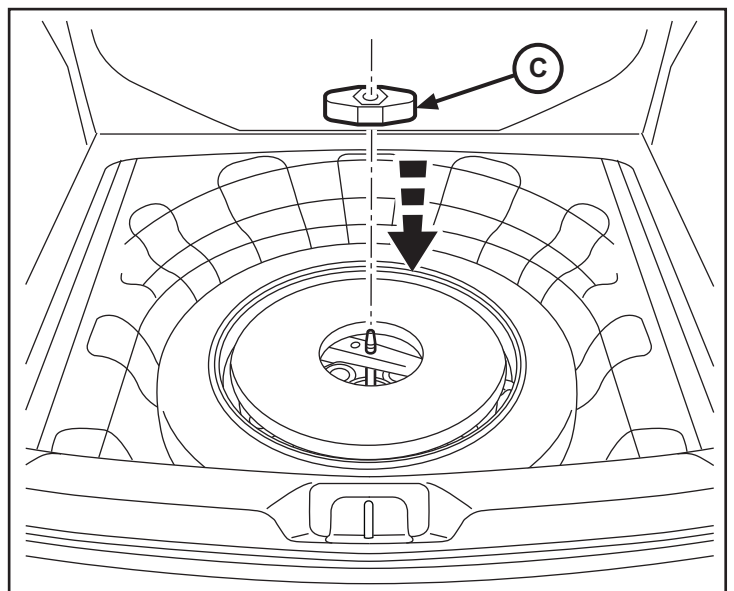

8. Reposez le panneau d'accès à la cavité sous le plancher du coffre.



# Neumático de repuesto

DODGE DART

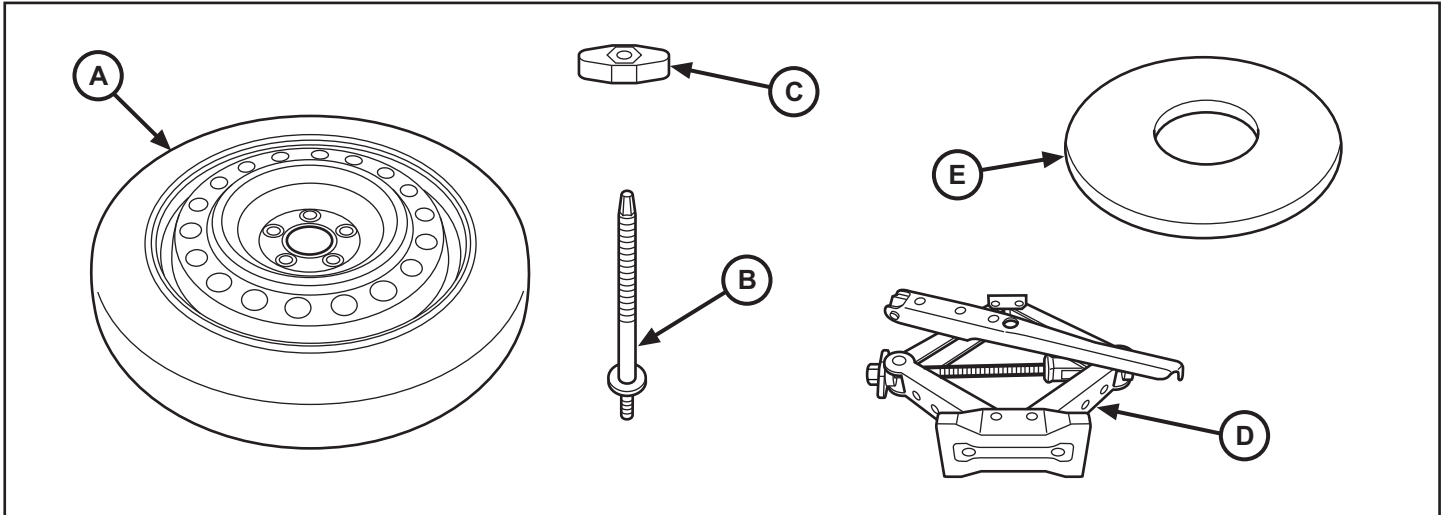

ELEMENTO	DESCRIPCIÓN	CANTIDAD
A	Neumático de repuesto	1
B	Eje de montaje	1
C	Tuerca mariposa	1
D	Conjunto de gato	1
E	Disco de protección	1

## HERRAMIENTAS NECESARIAS

Dado de 5.5mm

Torquímetro

## Neumático de repuesto

1. Imagen de la ubicación del montaje.

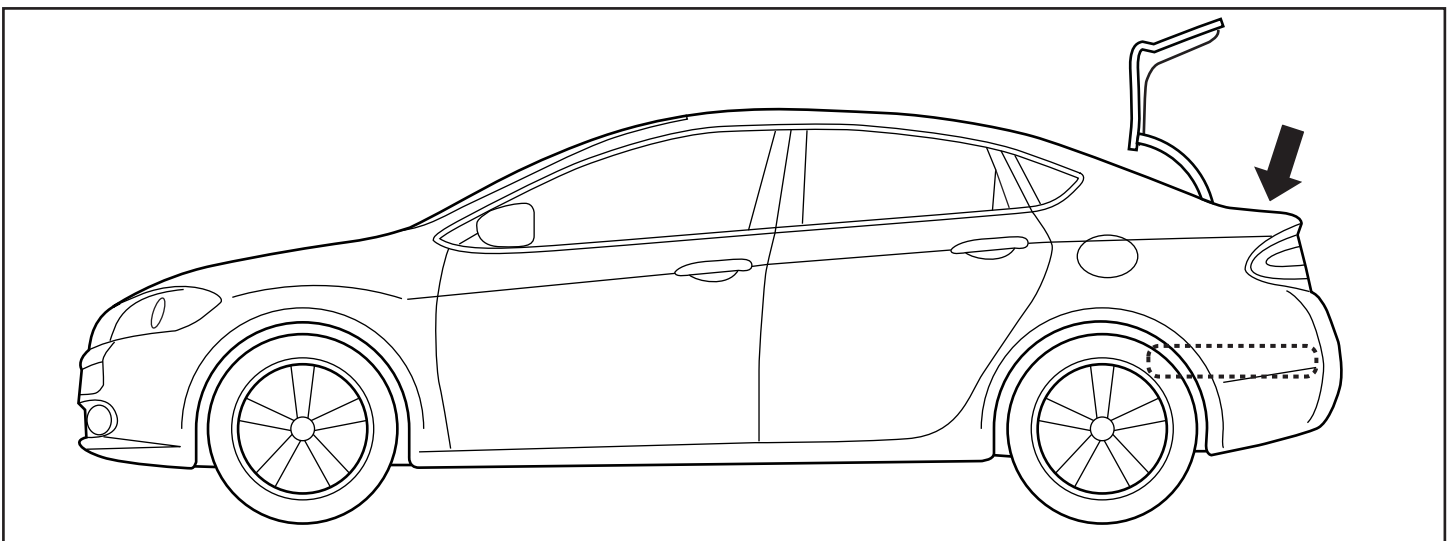

2. Abra el maletero. Quite el panel de acceso de piso.

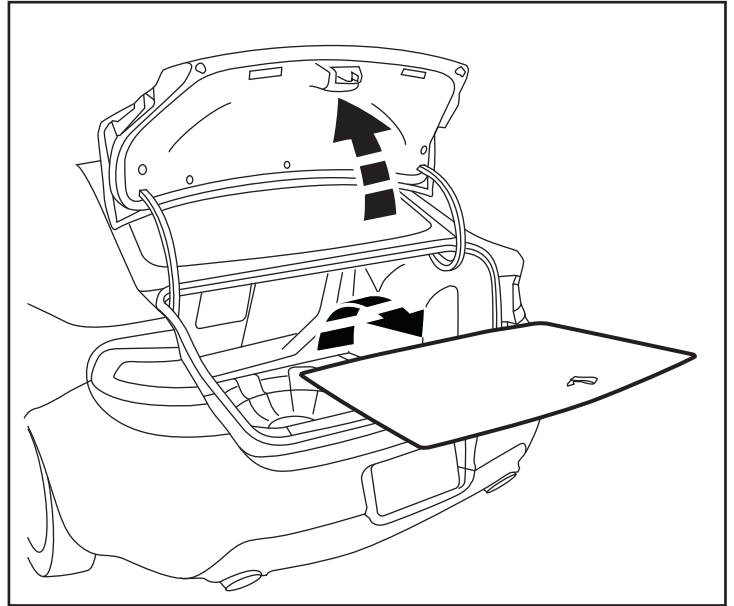

3. Enrosque el eje de montaje en el soporte de la base central. Use un dado de 5.5mm y un torquímetro para apretar el eje a 35 Nm (26 pies-lb).

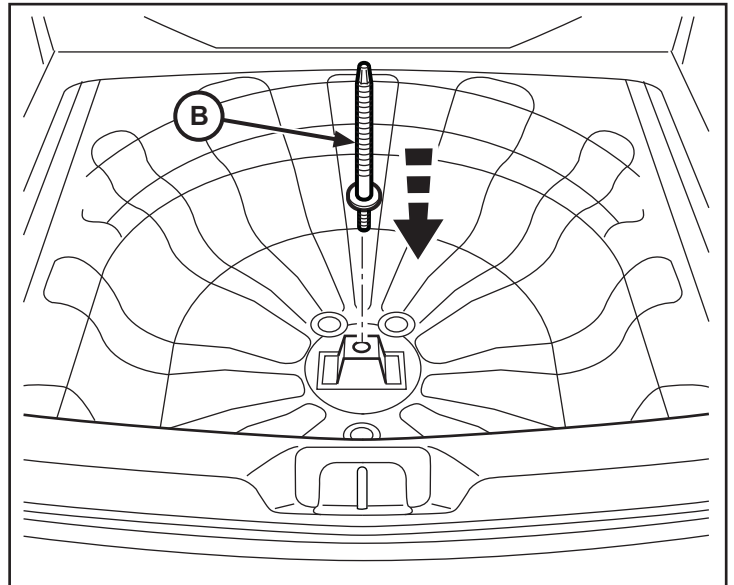

4. Coloque el neumático de repuesto en la cavidad de la cajuela cerciorándose de que el eje pasa a través del centro del neumático.

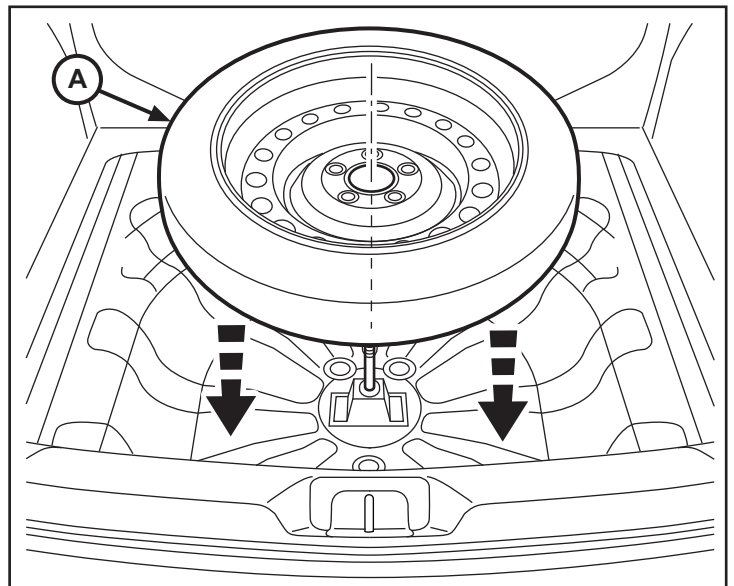



5. Deslice cuidadosamente el conjunto de gato sobre el eje de montaje y dentro del neumático de repuesto. Compruebe que el eje de montaje pasa por el hueco central en el mango del gato.

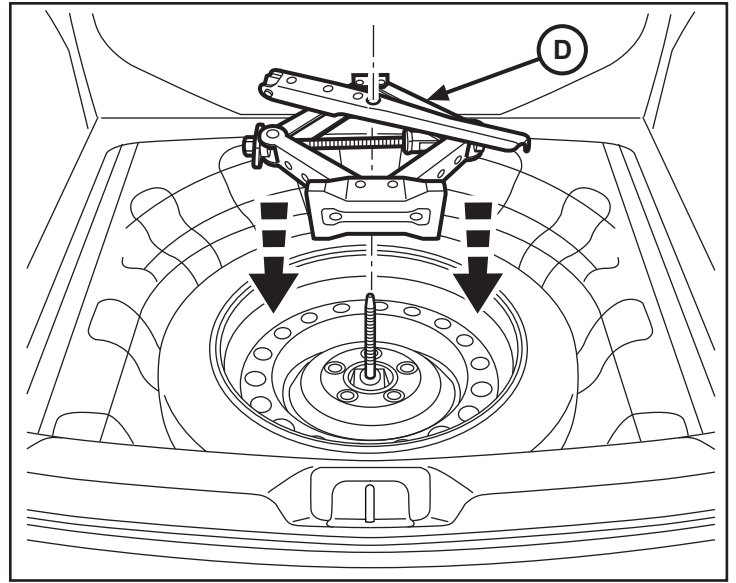

6. Coloque el disco protector en su lugar sobre el gato.

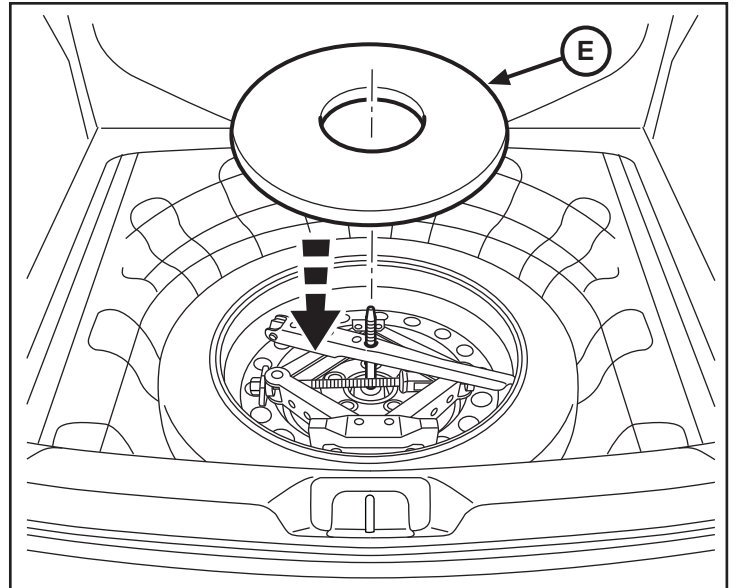

7. Sujete firmemente el neumático de repuesto y el conjunto de gato con la tuerca mariposa. No apriete demasiado.

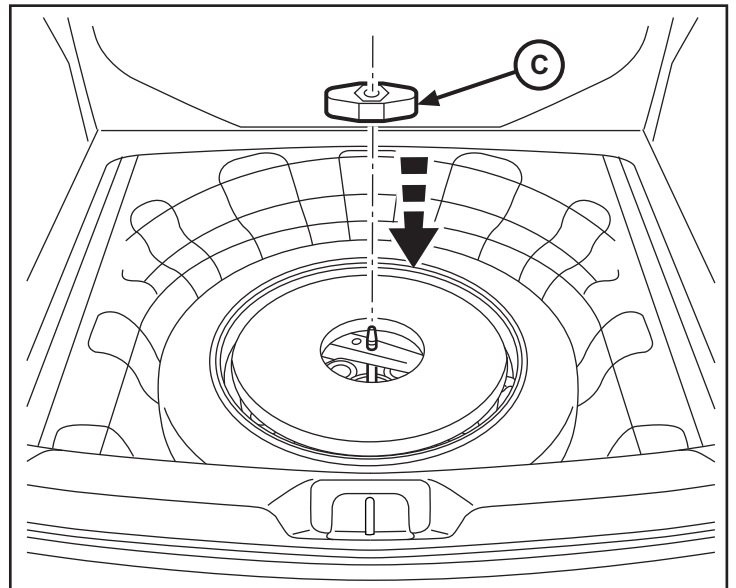

8. Reinstale el panel de acceso de piso dentro del maletero.