

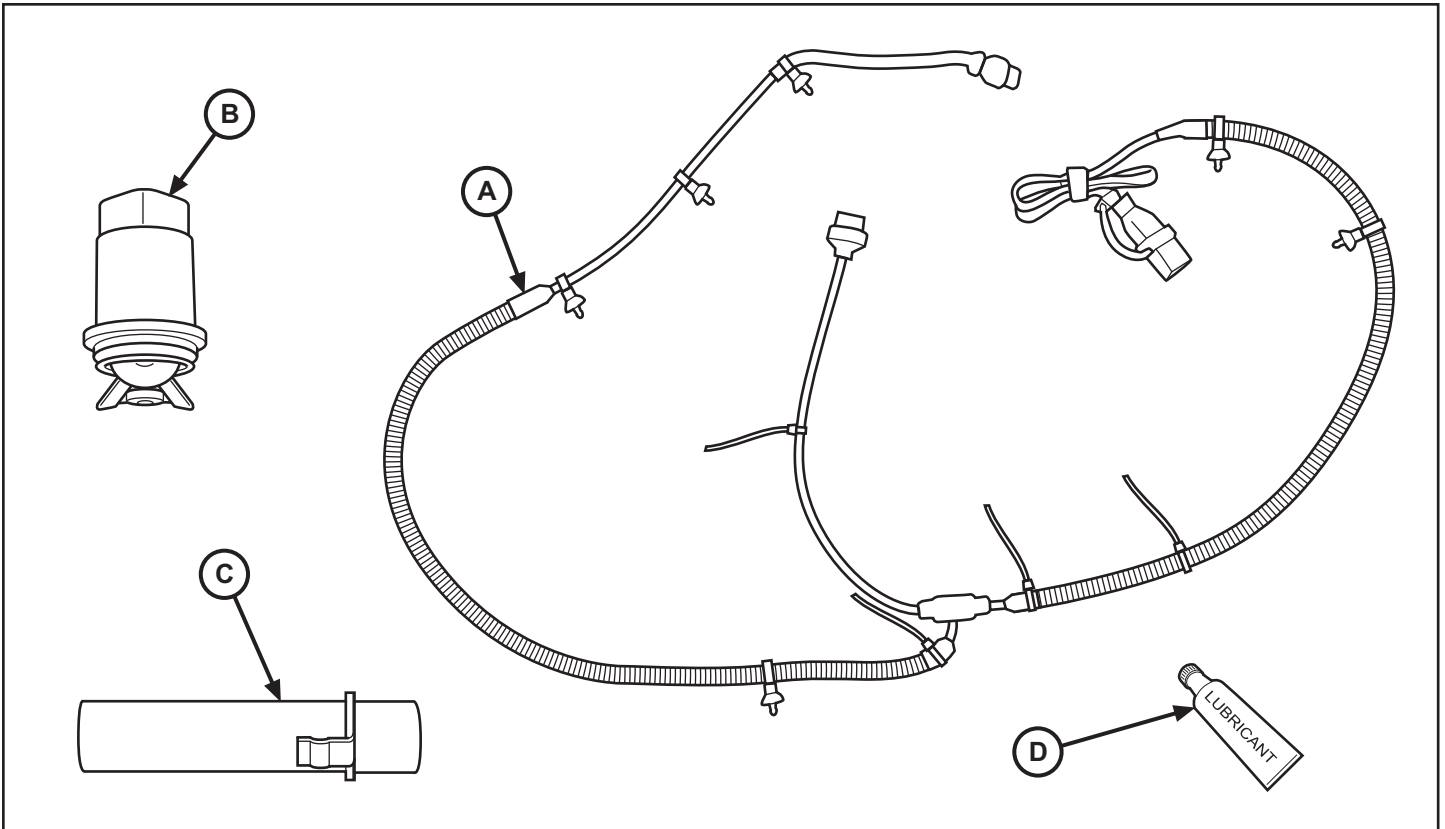

1.4L Automatic Engine Block Heater

www.mopar.com



CALL OUT	DESCRIPTION	QUANTITY
A	Connector Harness	1
B	Upper Heater Element	1
C	Lower Heater Element	1
D	Lubricant	1

TOOLS REQUIRED					
Trim Stick	Pry Tool	Hammer	Chisel	Torque Wrench	Wire Cutters

1. Open hood.

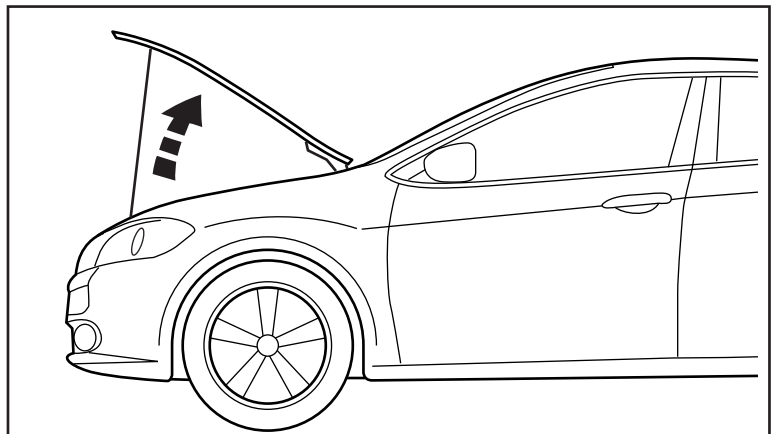

2. Use a pry tool to carefully remove the cover panel (1) from the top of the engine.

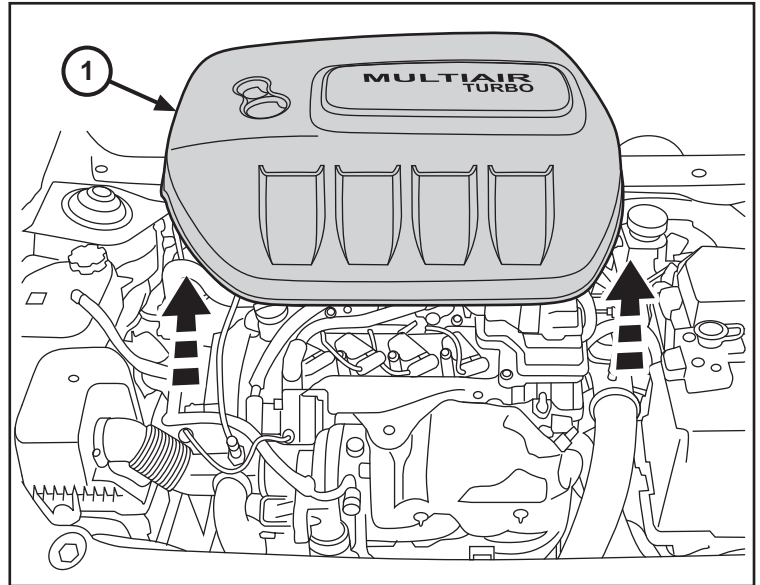

3. Carefully route both red plug ends of the Connector Harness (A) down through the back of the engine compartment as shown.

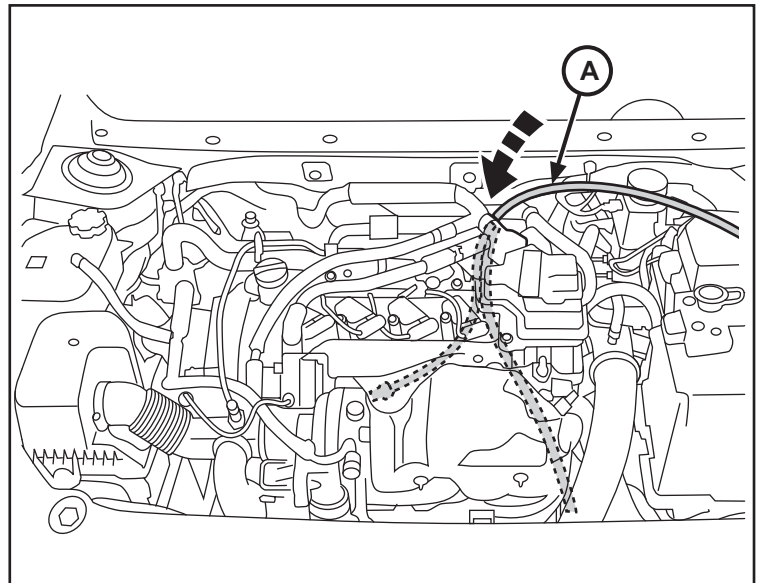

4. Raise vehicle.

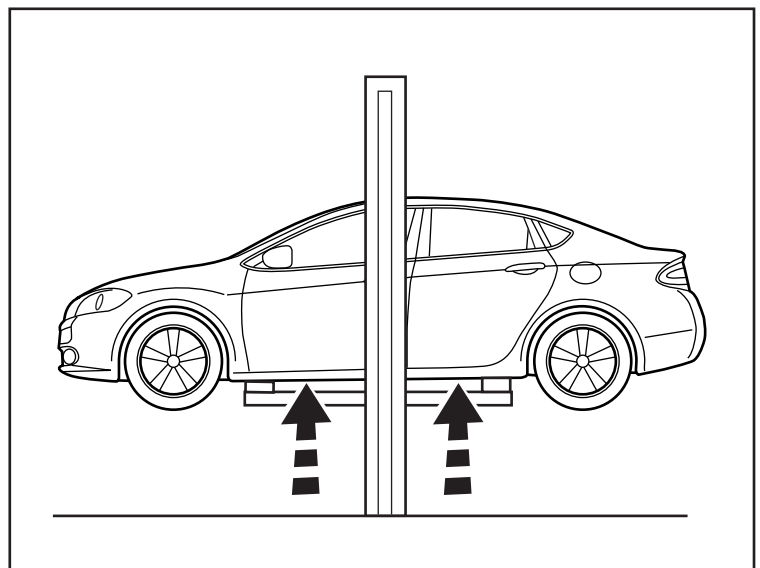

5. Remove twelve (12) fasteners from lower engine cover panel. Remove the panel.

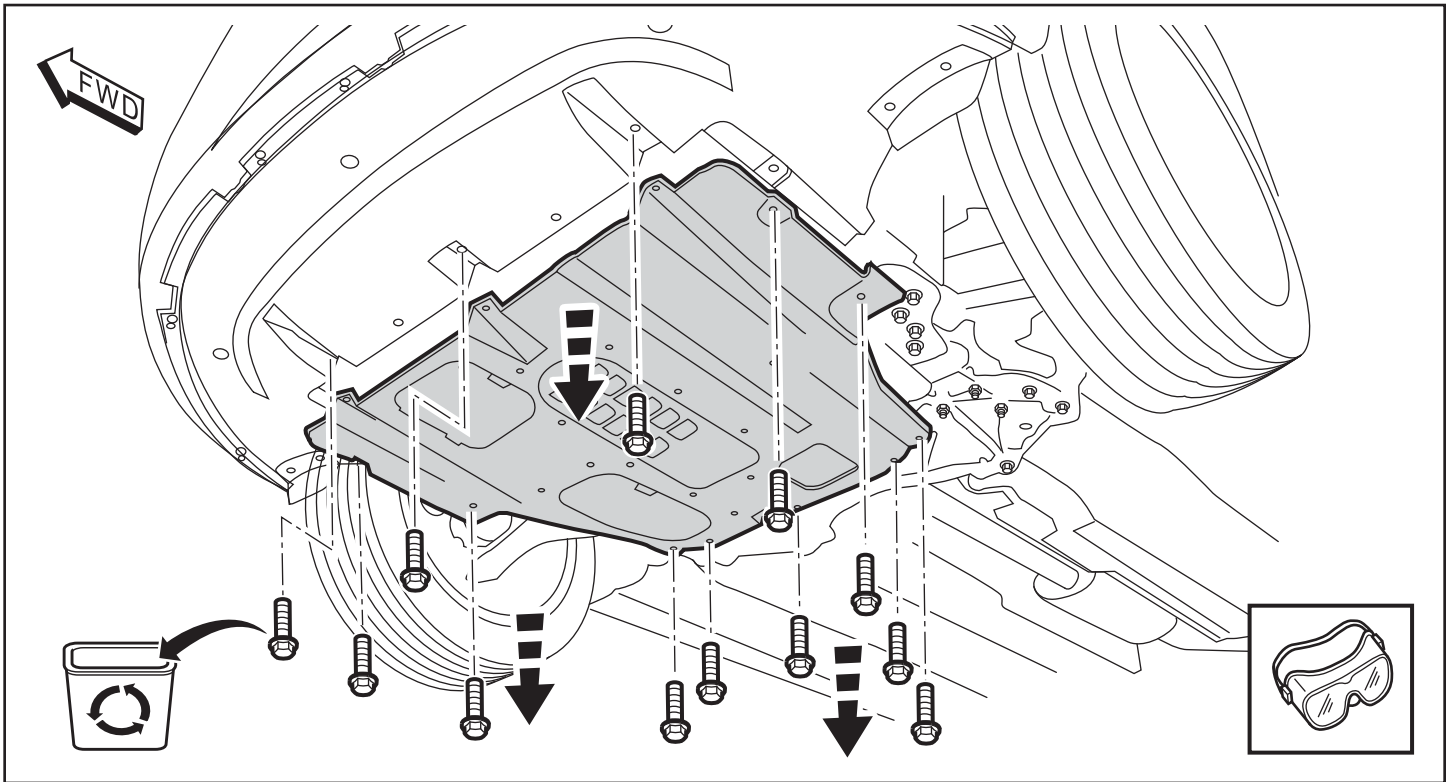

6. Purge coolant system according to factory specification for vehicle.

7. This reference illustration shows the mounting locations of the two heating elements (B) and (C) as well as the final routing of the Connector Harness (A) along the back of the engine.

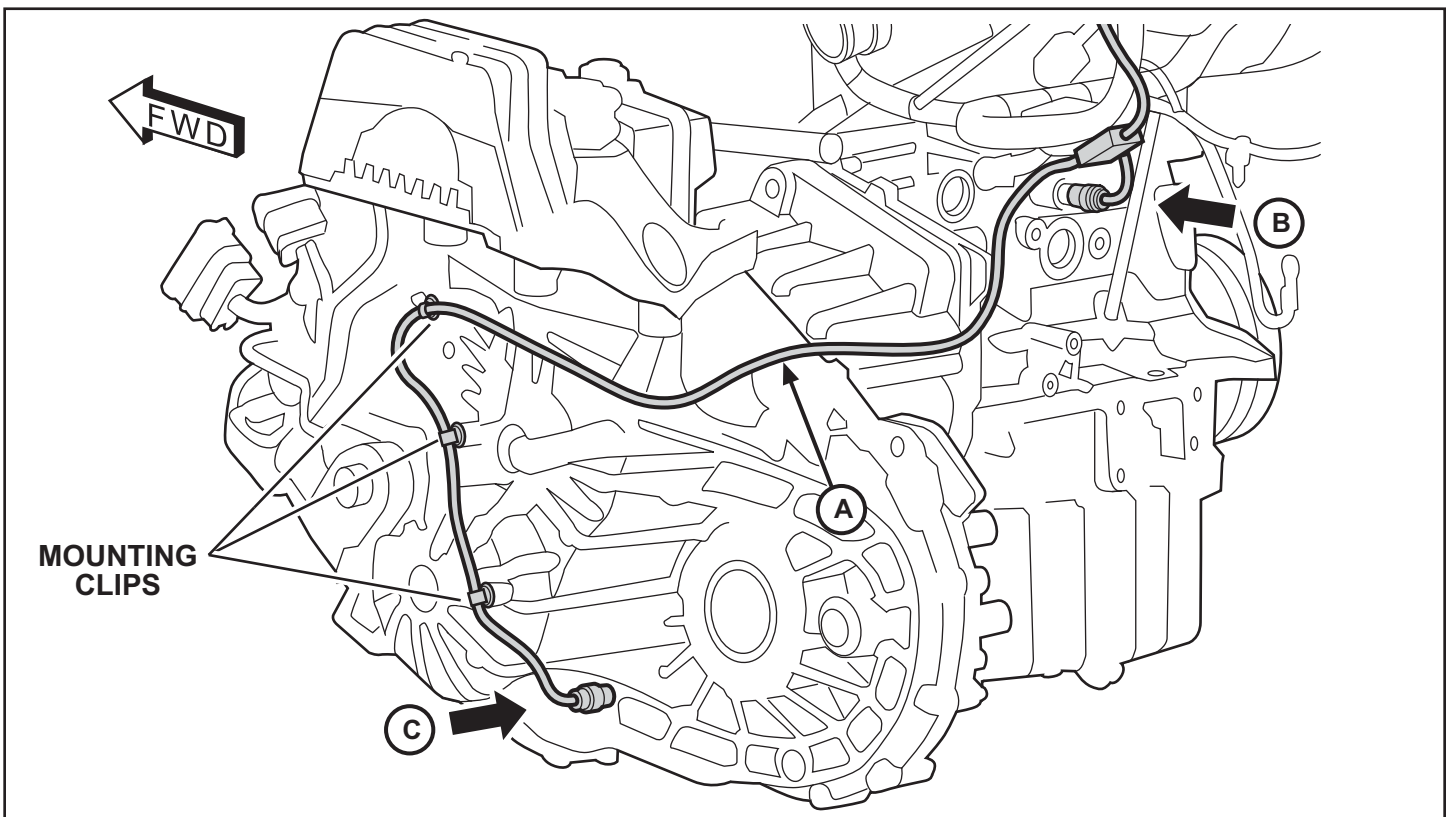

8. Looking up at the back of the engine from below, locate the two round plug caps just above the passenger side half-shaft (1).

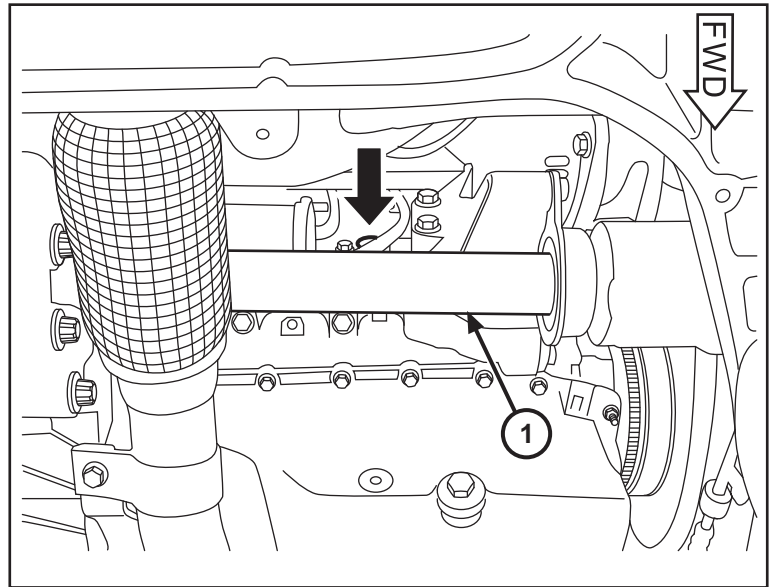

9. Carefully pry out the **TOP** plug cap (1) from the back of the engine block.

NOTE: Access to plug is limited. A hammer and chisel or large flathead screwdriver are recommended to dislodge it. Plug may be damaged during removal as it will not be re-used.

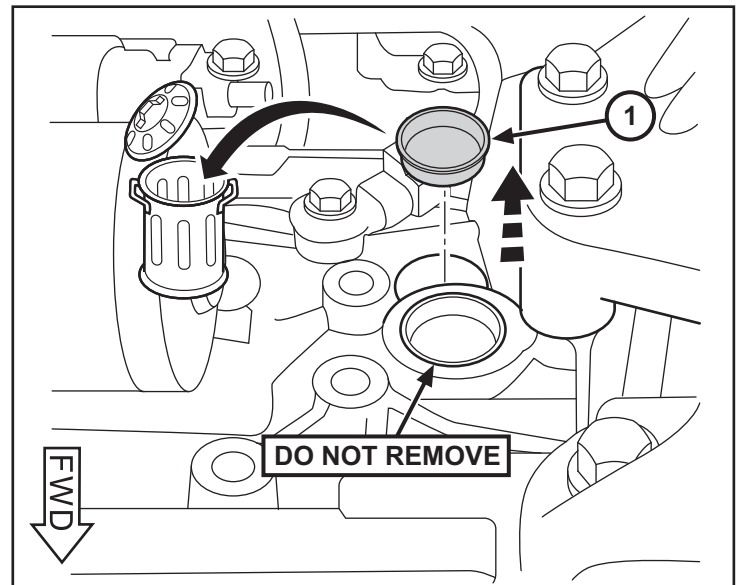

NOTE: This is an alternate view of the rear of the engine block. Hoses and other components are hidden to help clarify the location of the plug that needs to be removed.

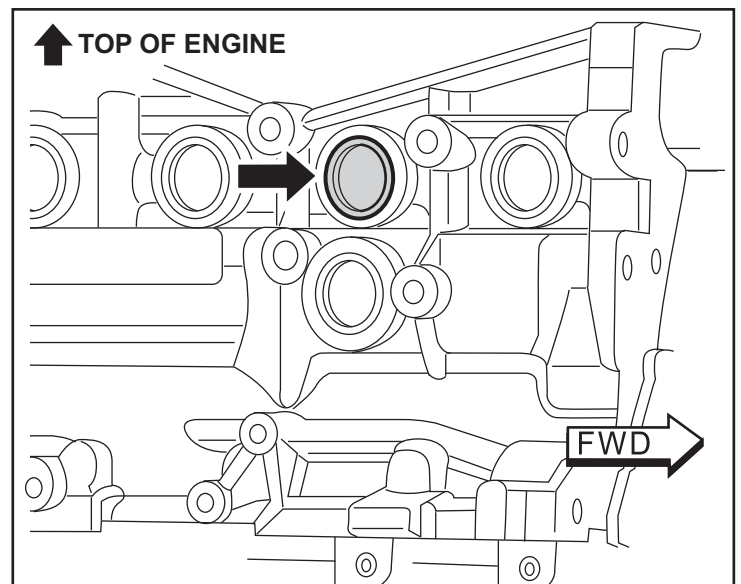

10. Insert Heater Element (B) into the opening.

NOTE: Be sure to apply lubricant (D) to the O-ring side of the heating element before inserting.

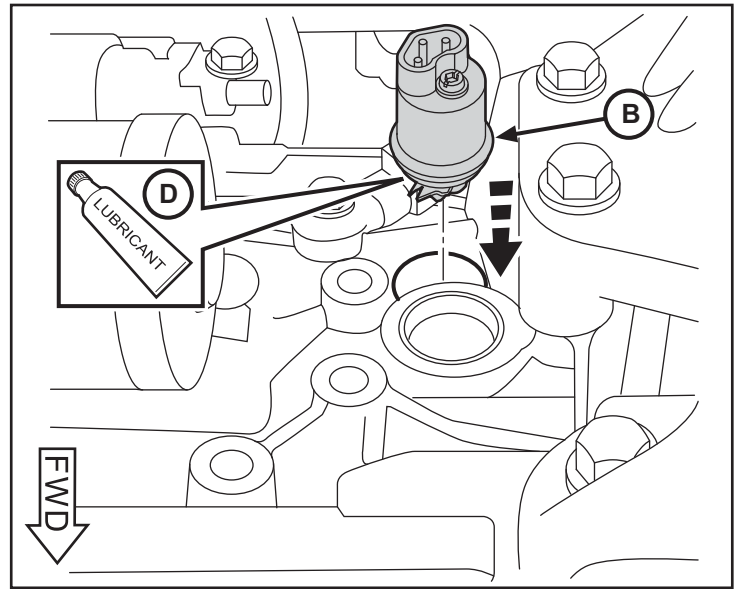
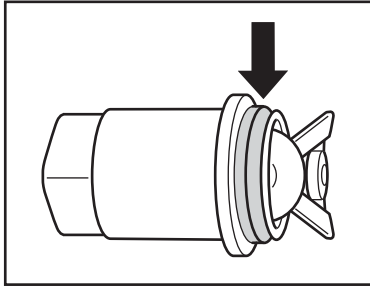

11. Position the Heater Element (B) so that the tightening screw (2) is on the bottom for easier access. Tighten the screw to 20 in-lb (+/- 2 in-lb) to secure the heater element in to the engine.

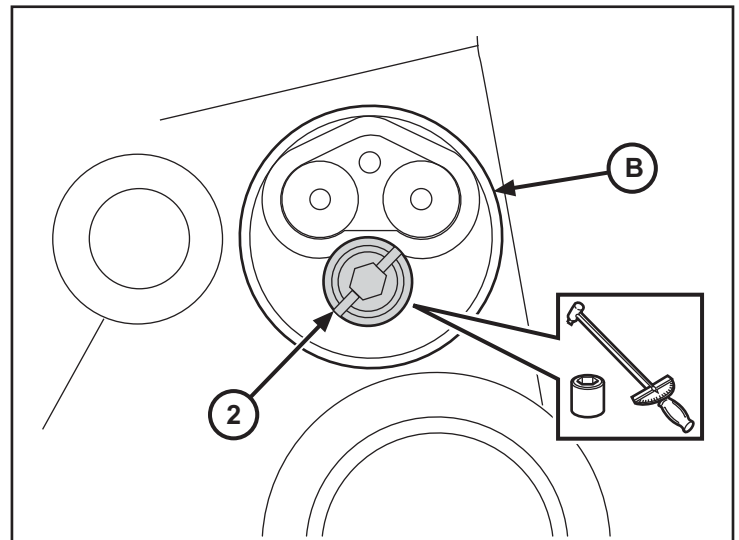

12. Connect the red plug end from the **shorter** section of the Connector Harness (A) into Heater Element (B).

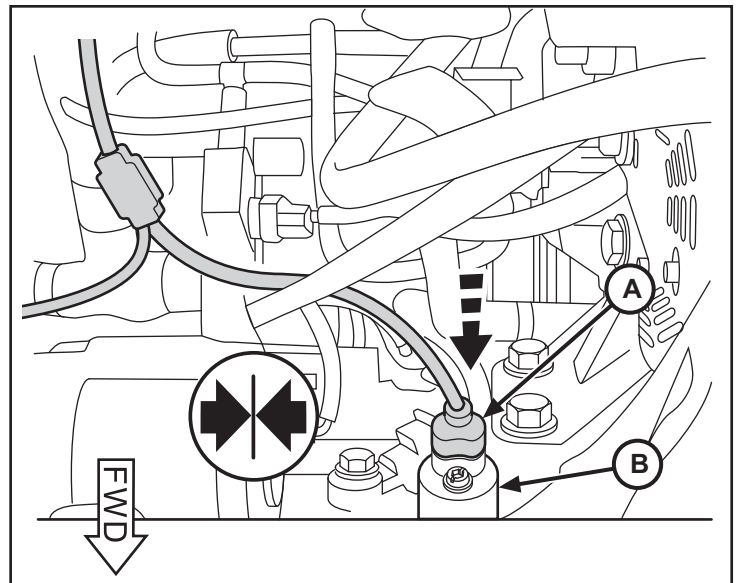

13. Route the Connector Harness (A) up along the hoses at the back of the engine as shown. Secure Connector Harness (A) along the hoses with the cable ties (3) provided on the harness.

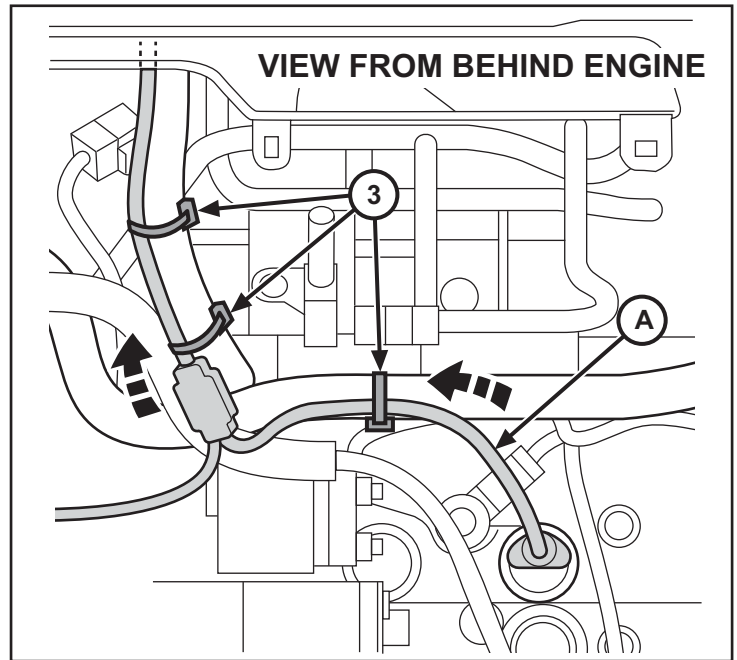

14. On the driver side, locate the round opening on the lower left side of the transmission near the driver shaft boot. Insert Heater Element (C) into the opening. Press in until the clip snaps into place.

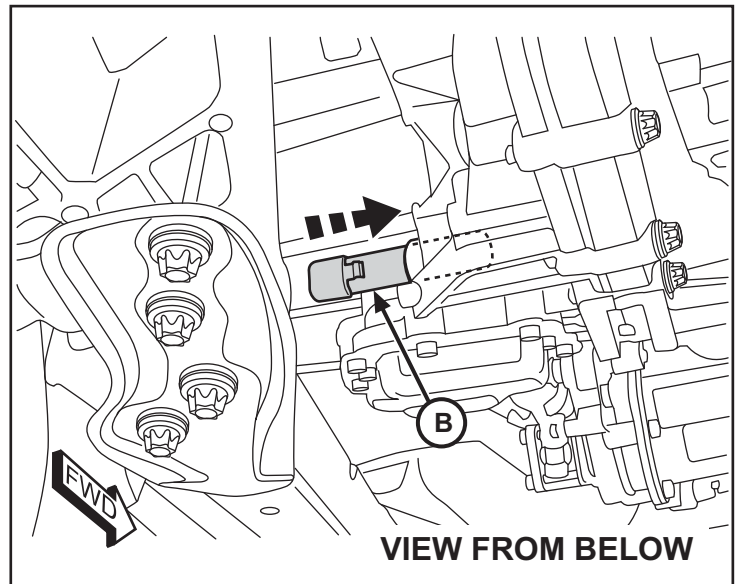

15. Route the **longer** section of the Connector Harness along the back of the engine. **See Fig 7 for reference.** Connect the red plug end of the Connector Harness (A) into the Heater Element (C)

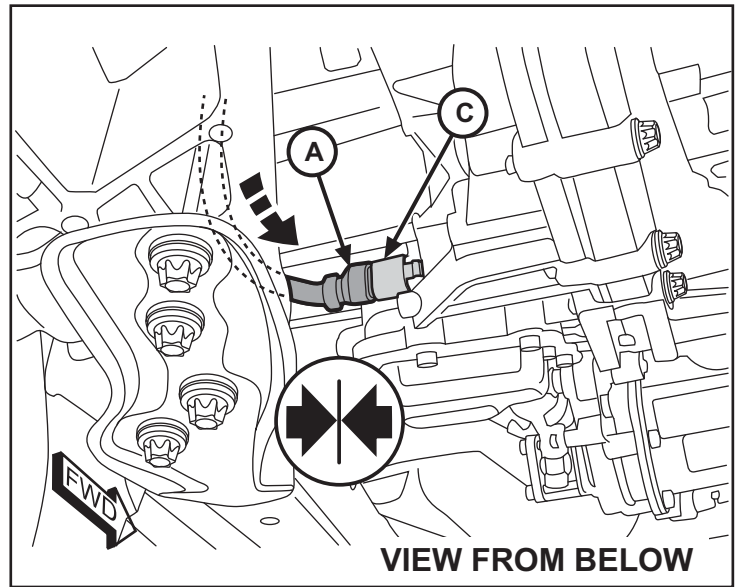

16. Secure the Connector Harness (A) by attaching the mounting clips (4) provided on the harness. Two of the locations are shown here on the driver side of the transmission. The third location is higher up along the harness and can not be seen in this view. **See Fig 7 for reference.**

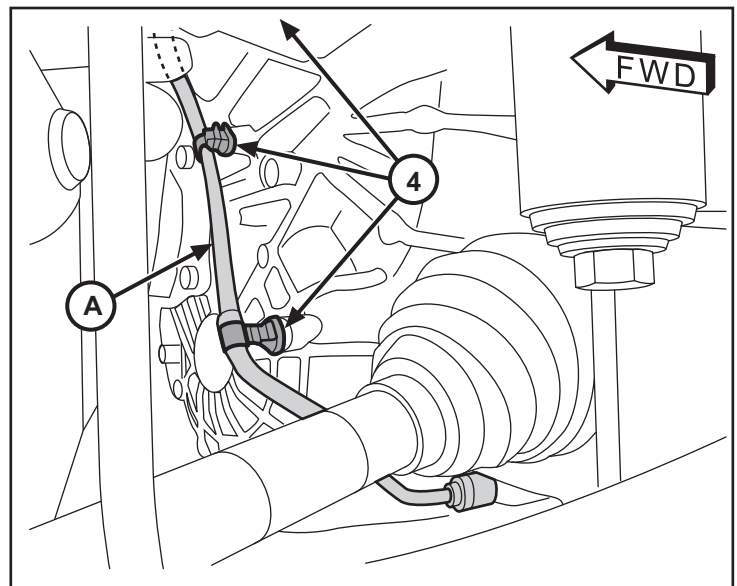

17. Lower the vehicle.

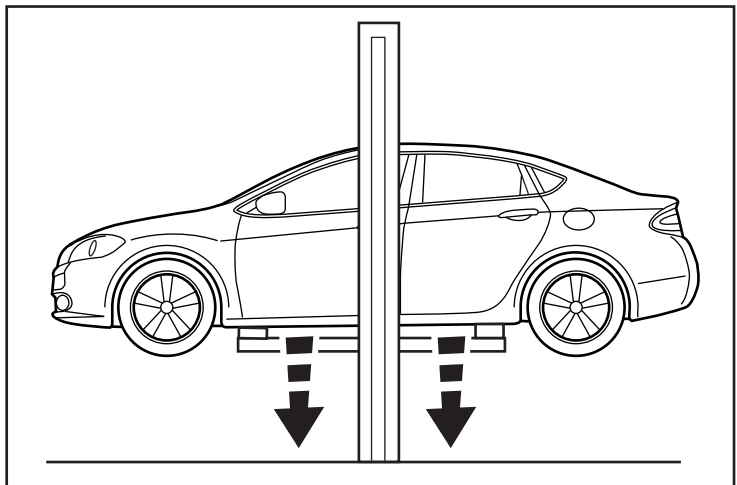

18. Route the Connector Harness (A) over towards the driver side of the engine compartment behind the fuse box as shown. Secure along the existing vehicle harness with cable tie (3) and mounting clips (4) provided on harness.

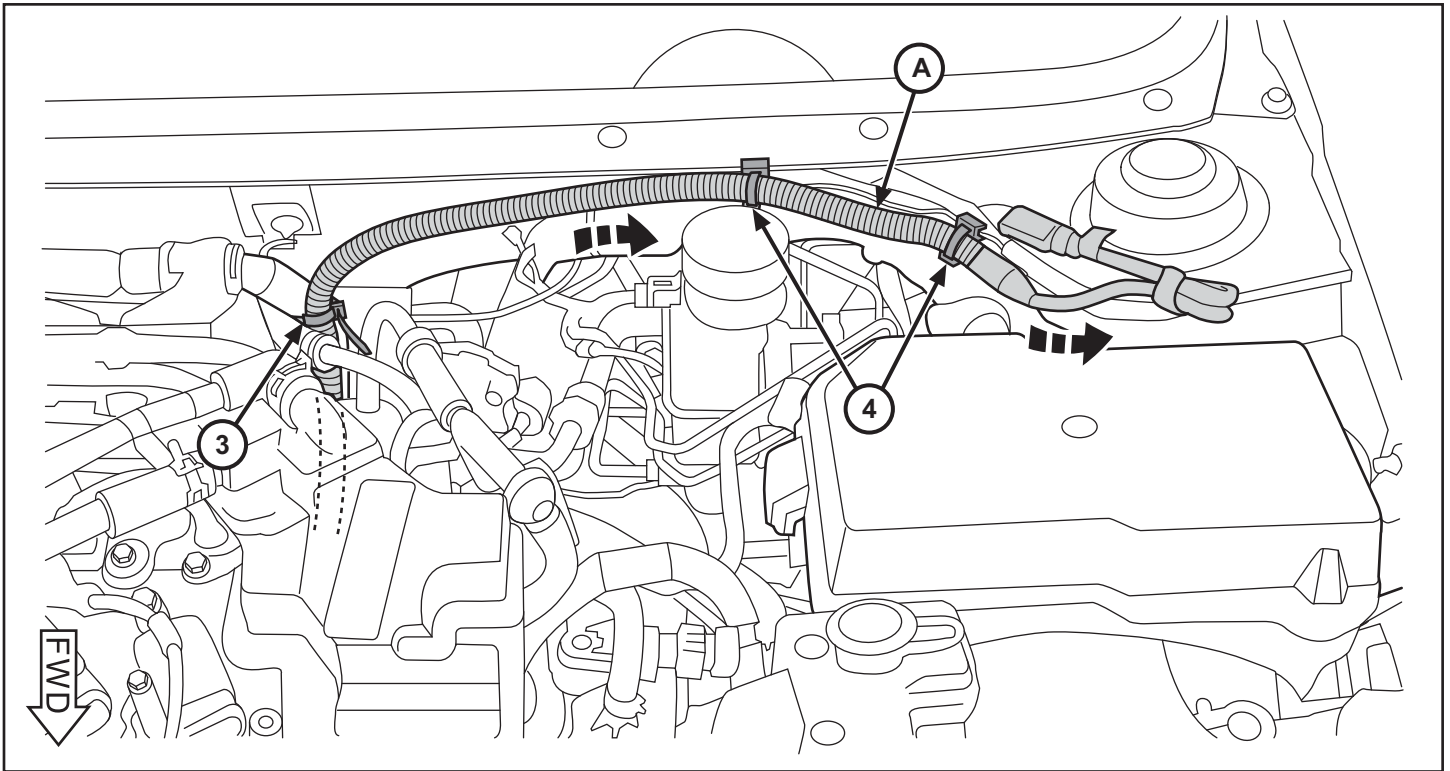

19. Check all connections and trim all cable ties.
20. **Refill coolant system** according to factory specification for vehicle.
21. Raise vehicle. **Reverse Step 5** to reinstall the lower engine panel.
22. Lower vehicle. **Reverse Step 2** to reinstall the engine cover.



Chauffe-bloc de moteur 1.4L à transmission automatique

www.mopar.com

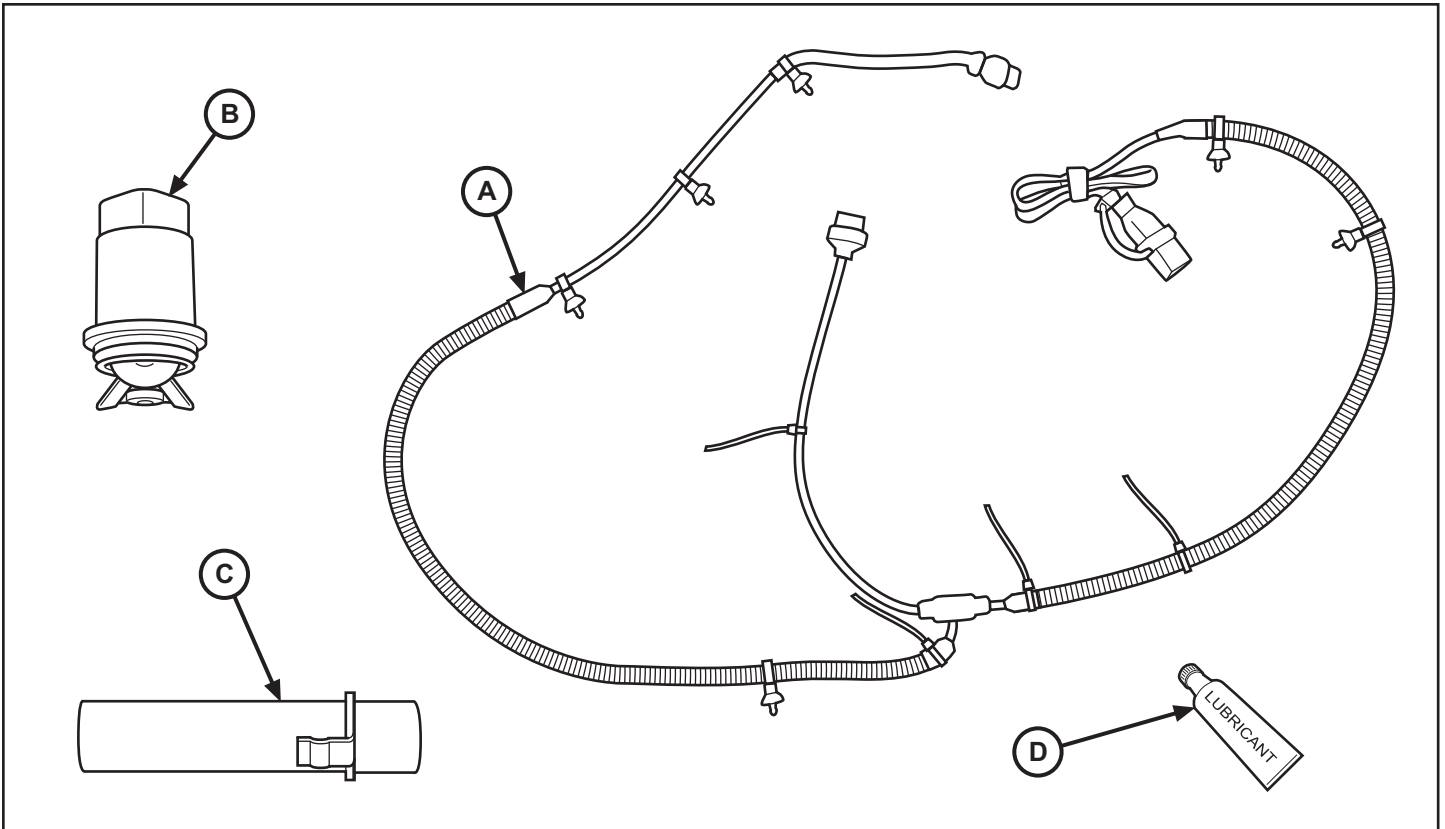

RÉFÉRENCE	DESCRIPTION	QUANTITÉ
A	Faisceau de connexion	1
B	Élément chauffant supérieur	1
C	Élément chauffant inférieur	1
D	Lubrifiant	1

OUTILS REQUIS

Outil pour garnitures	Outil levier	Marteau	Ciseau	Clé dynamométrique	Coupe-fils
-----------------------	--------------	---------	--------	--------------------	------------

1. Ouvrez le capot.

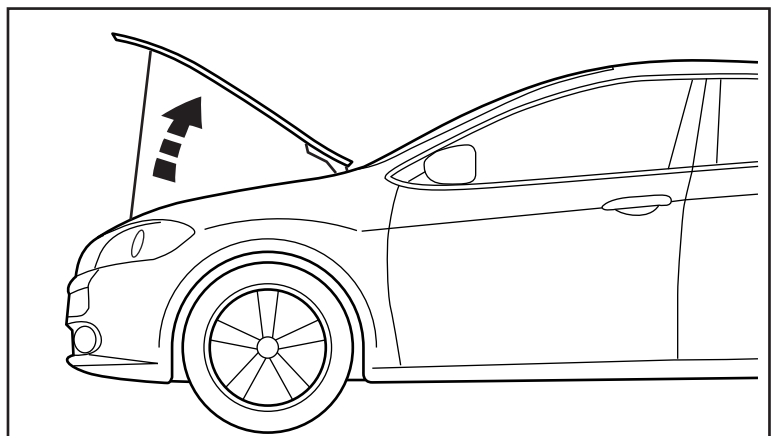

2. À l'aide de l'outil levier, déposez délicatement le panneau (1) du dessus du moteur.

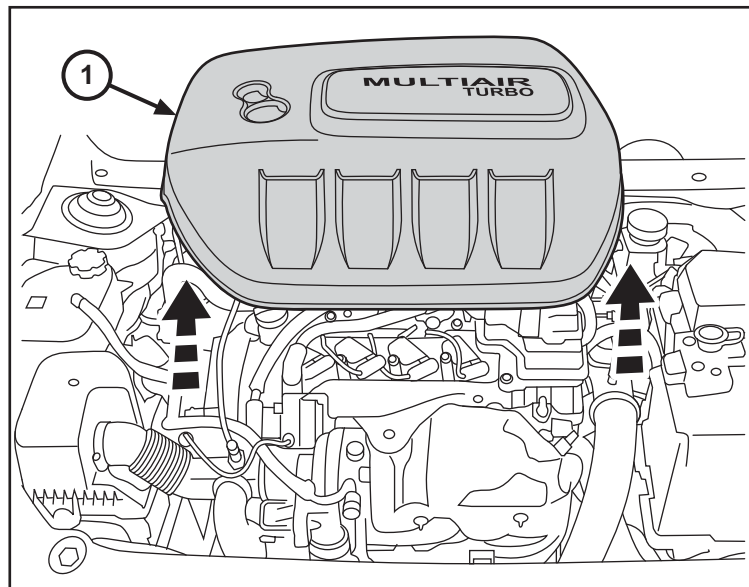

3. Acheminez soigneusement les deux connecteurs rouges d'extrémité du faisceau de connexion (A) vers le bas à l'arrière du compartiment moteur, comme montré.

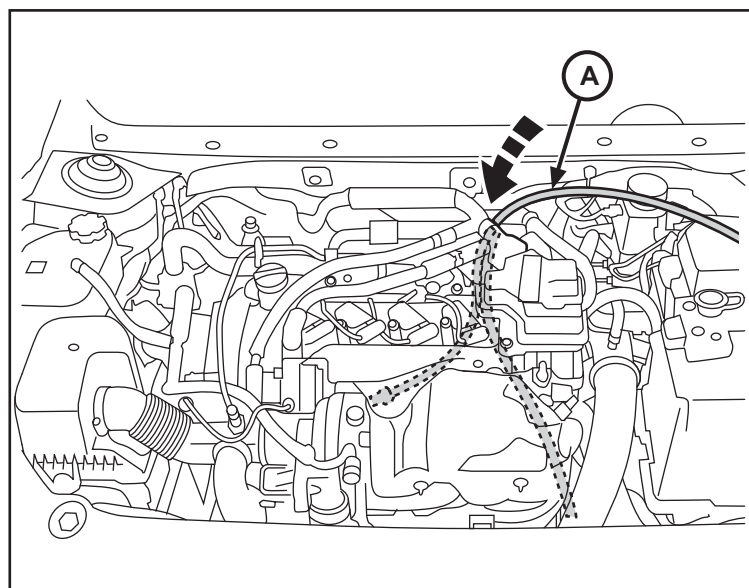

4. Élever le véhicule.

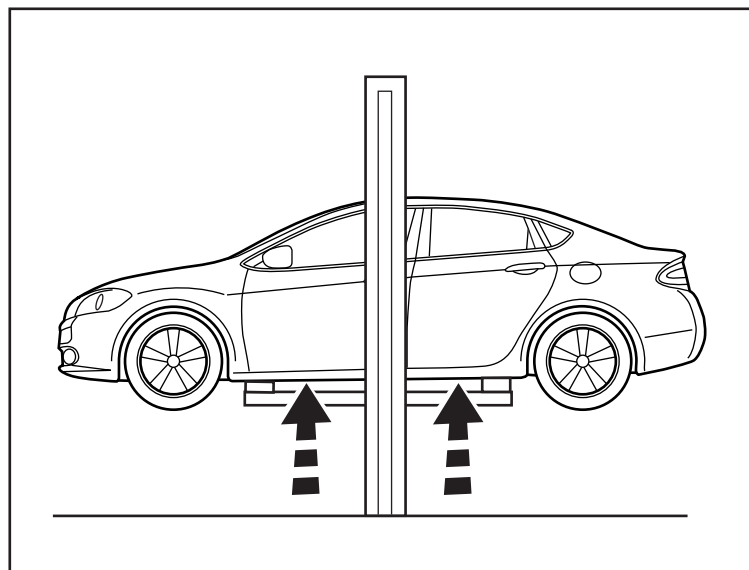

5. Déposez les douze (12) attaches du panneau sous le compartiment moteur et déposez le panneau.

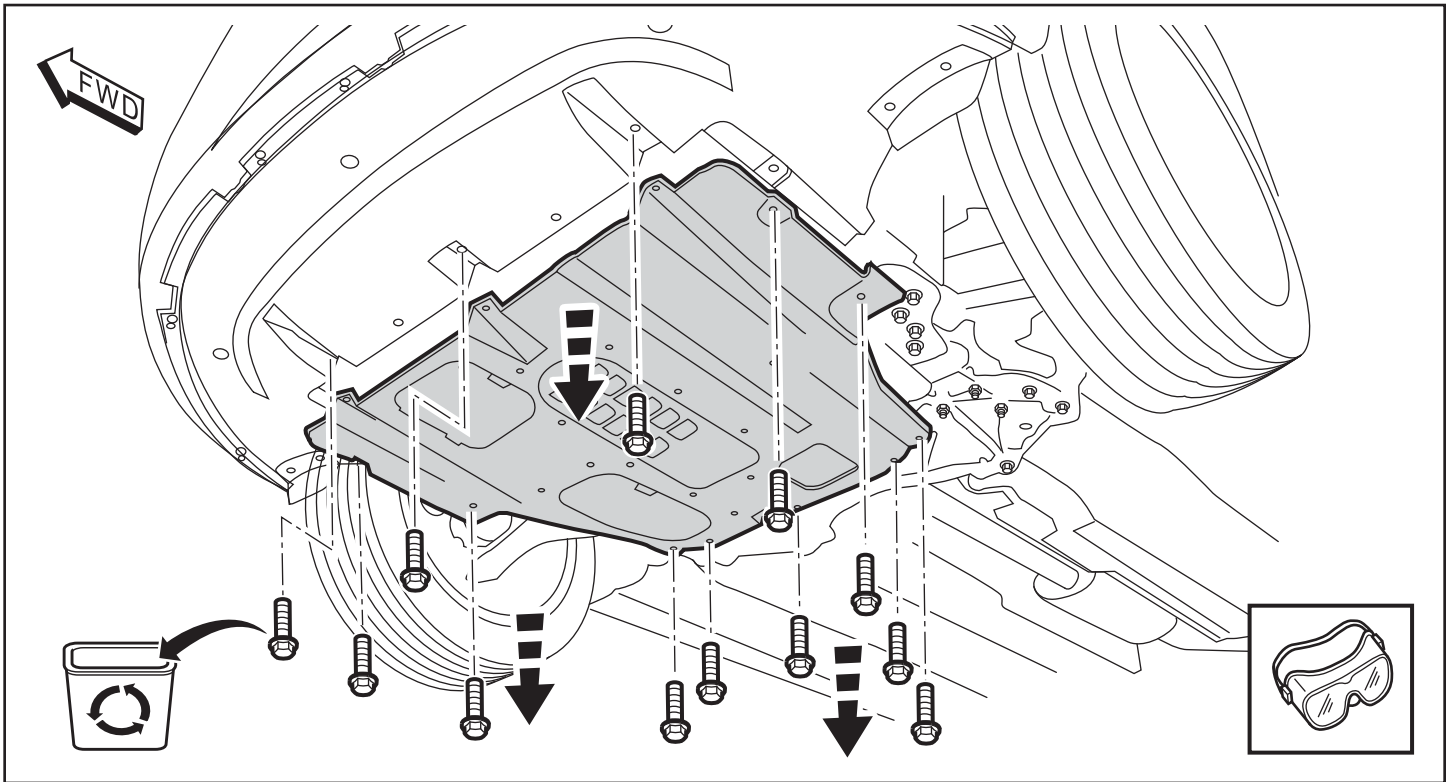

6. Purgez le système de refroidissement du véhicule selon les recommandations du fabricant.
7. Cette illustration de référence indique les emplacements de montage des deux éléments de chauffage (B) et (C) ainsi que la position finale du faisceau de connexion (A) à l'arrière du moteur.

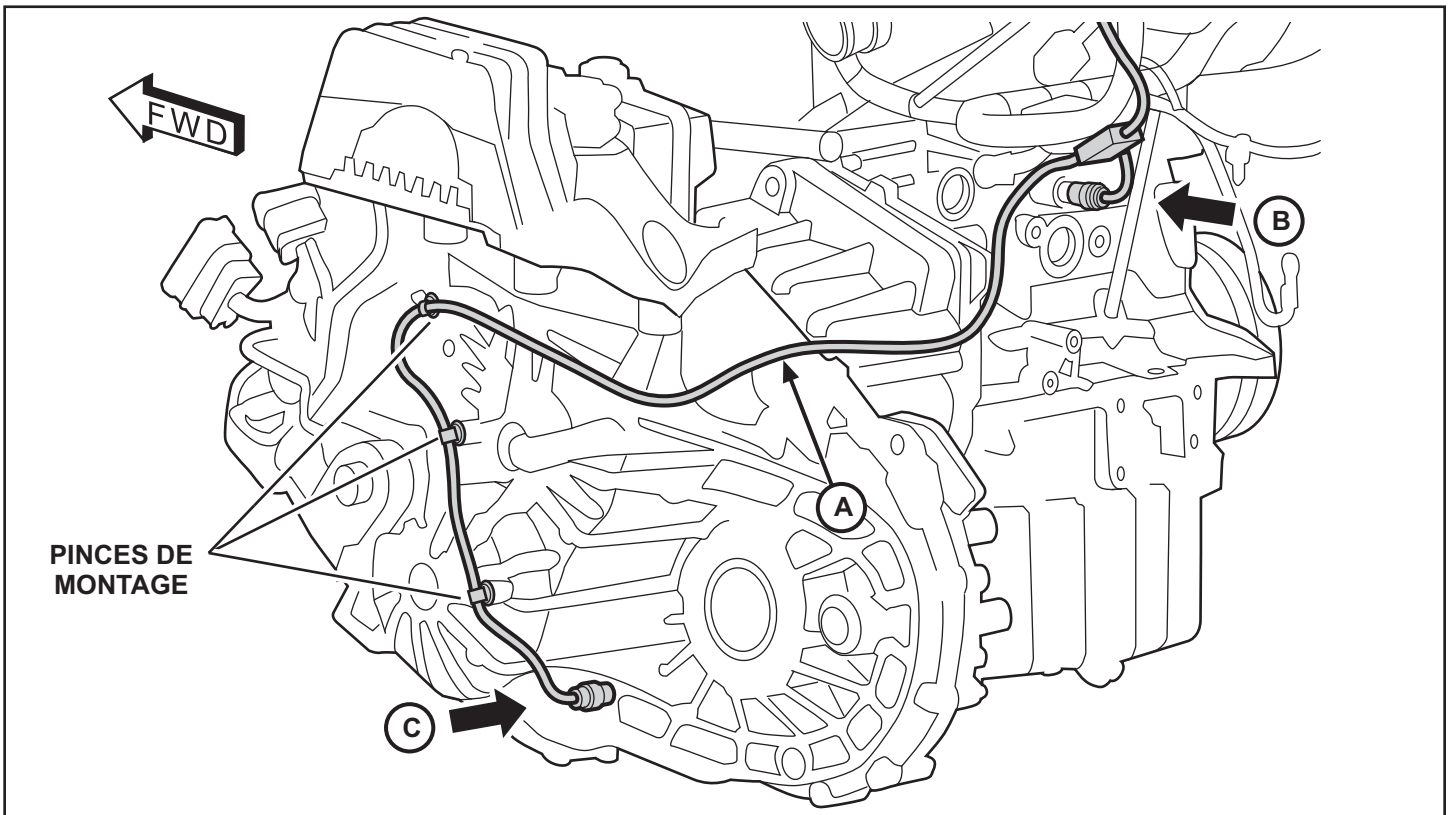

8. En regardant l'arrière du moteur par le dessous, localisez les deux bouchons ronds juste au-dessus de l'arbre court du côté passager (1).

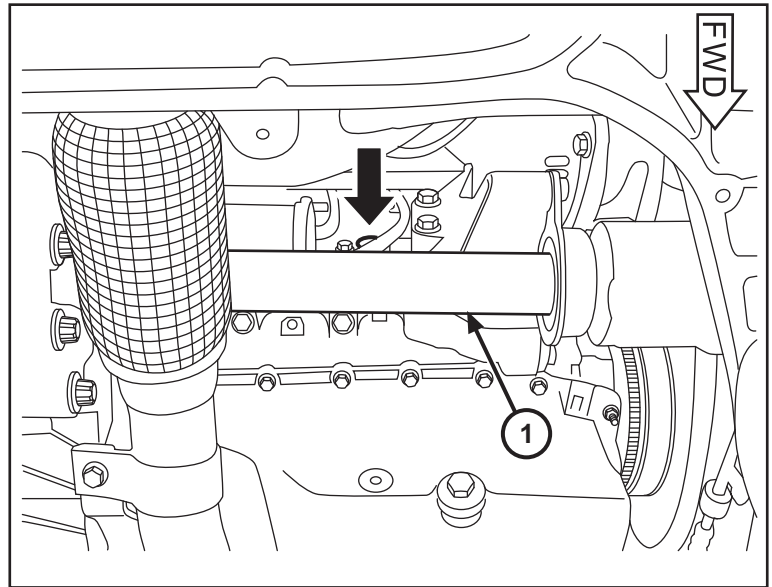

9. Extraire avec précaution le bouchon du **DESSUS** (1) à l'arrière du bloc moteur.

REMARQUE : L'accès au bouchon est limité. Un marteau et un ciseau ou un grand tournevis plat sont recommandés pour le déloger. L'endommagement du bouchon lors de sa dépose ne serait pas grave puisqu'il ne sera pas réutilisé.

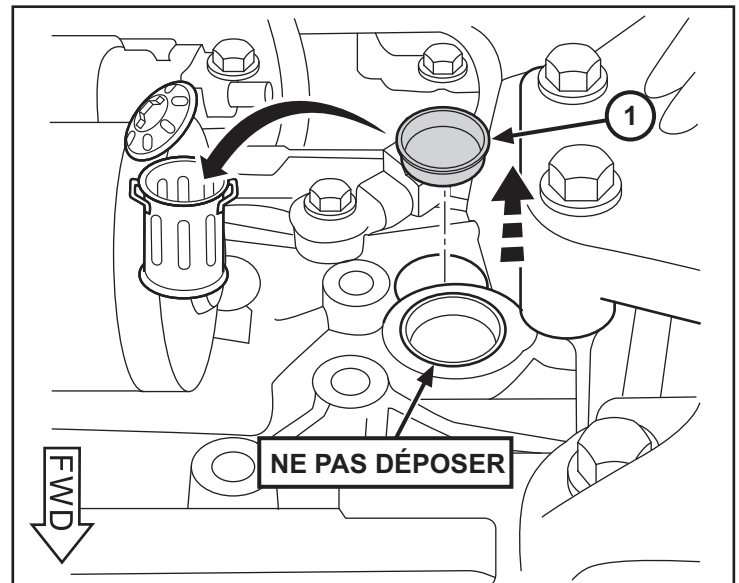

REMARQUE : Il s'agit d'une autre vue de l'arrière du bloc moteur. Les flexibles et les autres composants sont omis pour aider à préciser l'emplacement du bouchon qui doit être déposé.

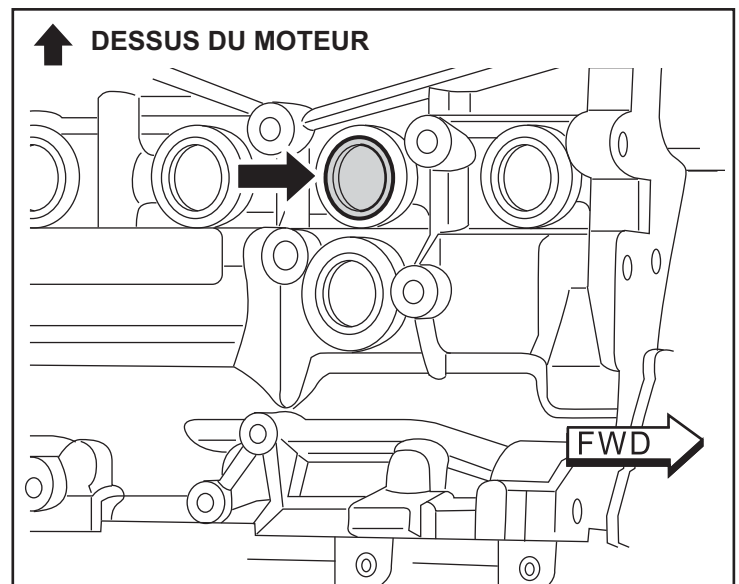

10. Insérer l'élément chauffant (B) dans l'ouverture.

REMARQUE : Veillez à appliquer du lubrifiant (C) sur le joint torique de l'élément chauffant avant de l'insérer.

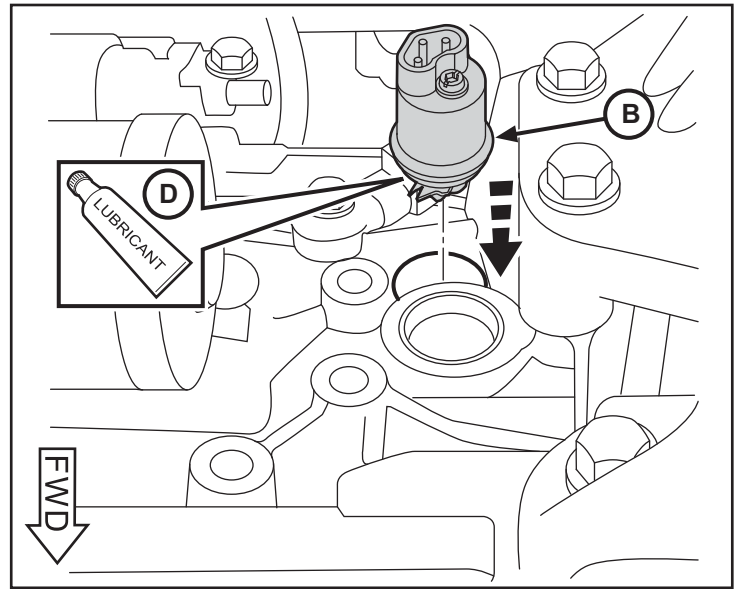
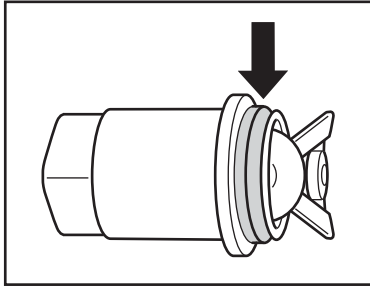

11. Afin d'en faciliter l'accès, positionner l'élément chauffant (B) de façon à ce que la vis de serrage (2) soit au bas. Serrer la vis à 2,25 N-m (20 lb-po.) [+ / - 0,23 N-m (+ / - 2 lb-po.)] pour fixer l'élément chauffant au moteur.

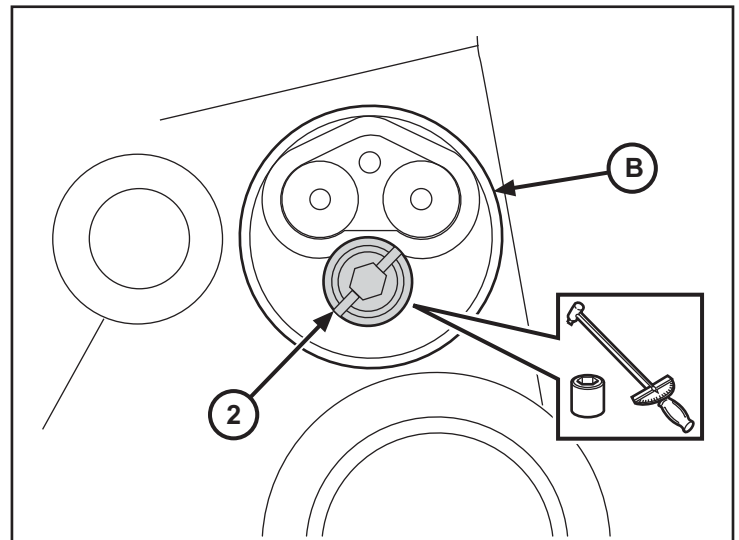

12. Brancher le connecteur rouge de l'extrémité de la partie la plus **courte** du faisceau de connexion (A) dans l'élément chauffant (B).

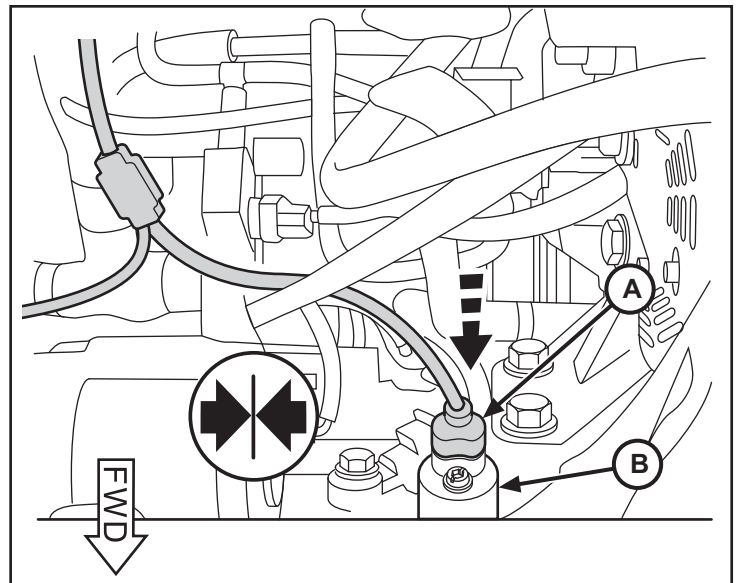

13. Acheminer le faisceau de connexion (A) le long des flexibles à l'arrière du moteur, comme montré. À l'aide des trois attaches serre-câble présentes sur le faisceau, fixer celui-ci le long des flexibles.

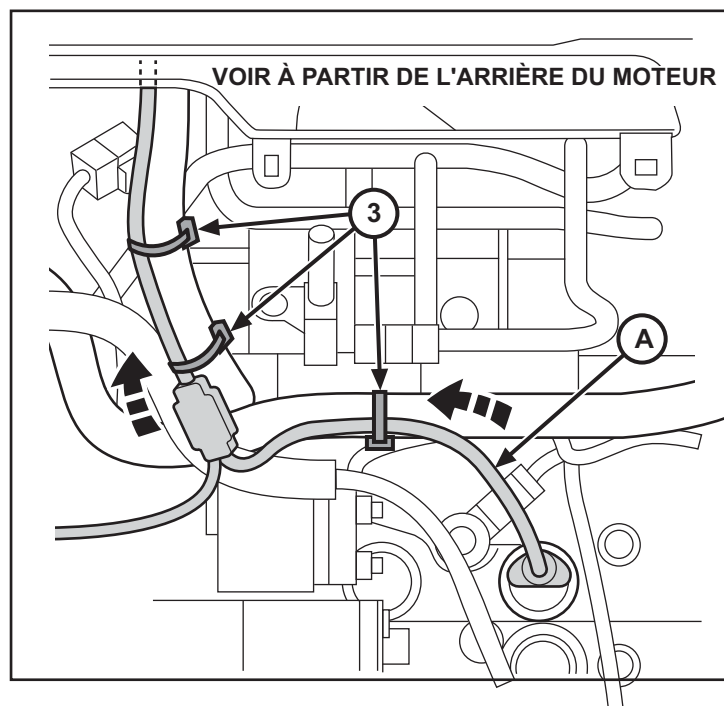

14. Du côté du conducteur, repérez l'ouverture ronde sur le côté inférieur gauche de la boîte de vitesses, près du soufflet pour joint universel. Insérer l'élément chauffant (B) dans l'ouverture. Appuyer sur l'élément jusqu'à ce que qu'il s'enclenche en place.

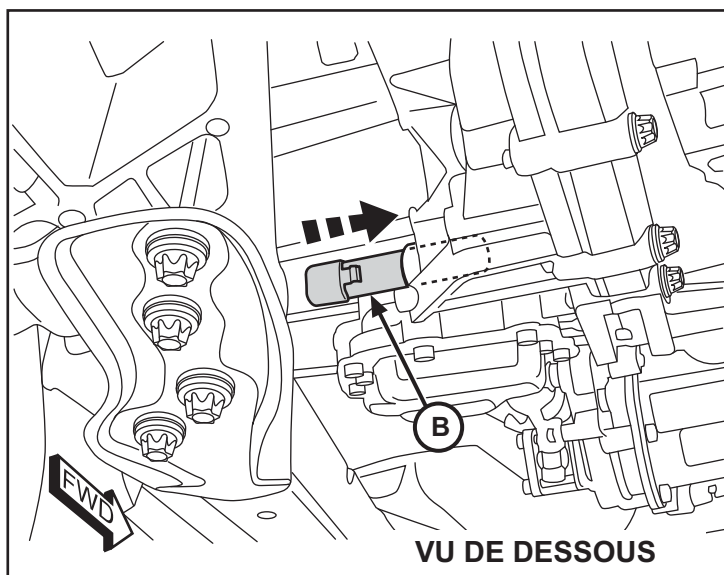

15. Acheminer la section la plus longue du faisceau de connexion à l'arrière du moteur. **Voir Fig. 7 pour référence.** Brancher le connecteur rouge de l'extrémité du faisceau de connexion (A) dans l'élément chauffant (C).

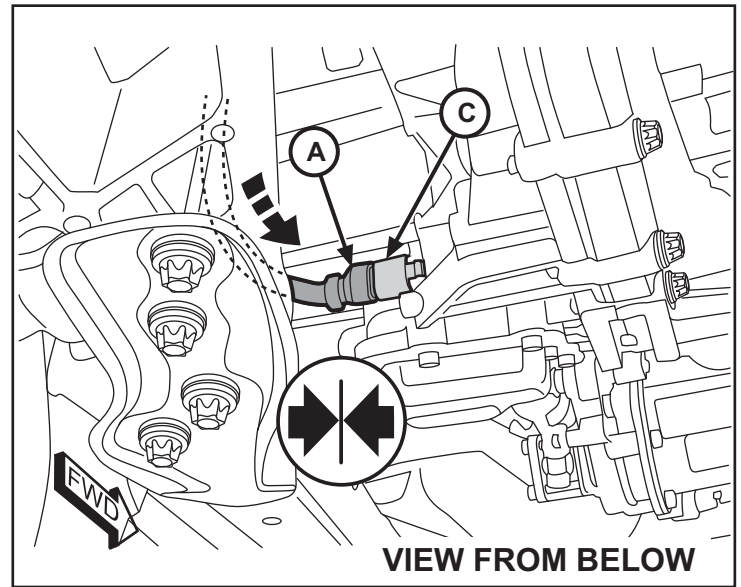

16. Fixer le faisceau de connexion (A) le long des flexibles avec les quatre (4) pinces de montage présentes sur le faisceau. Deux de ces emplacements sont montrés ici, côté conducteur de la boîte de vitesses. Le troisième emplacement est plus haut le long du faisceau et ne peut pas être montré dans cette vue. **Voir Fig. 7 pour référence.**

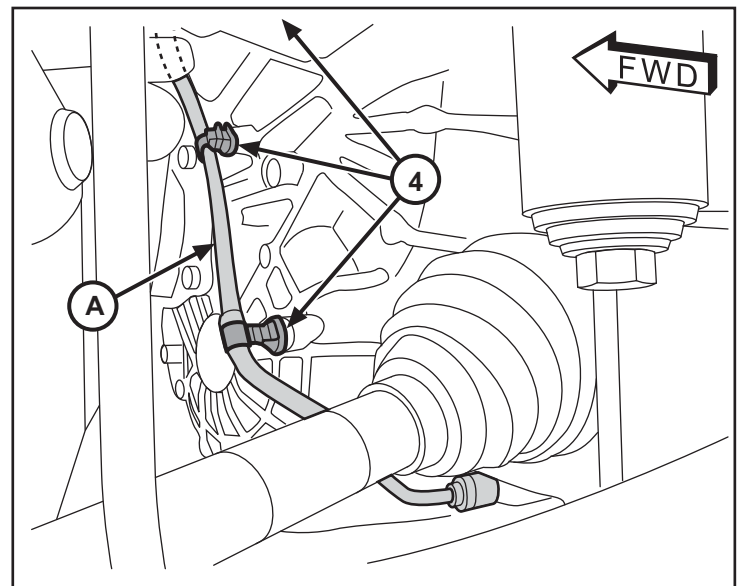

17. Abaisser le véhicule au sol.

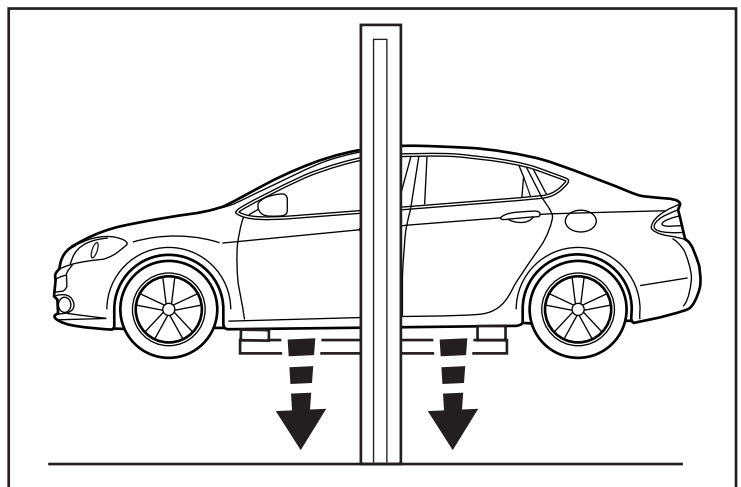

18. Comme illustré, acheminer le faisceau de connexion (A) vers le côté conducteur du compartiment moteur, derrière le boîtier de fusibles. À l'aide des trois (3) attaches serre-câble et quatre (4) pinces de montage présentes sur le faisceau, fixer le long du faisceau de câbles existant du véhicule.

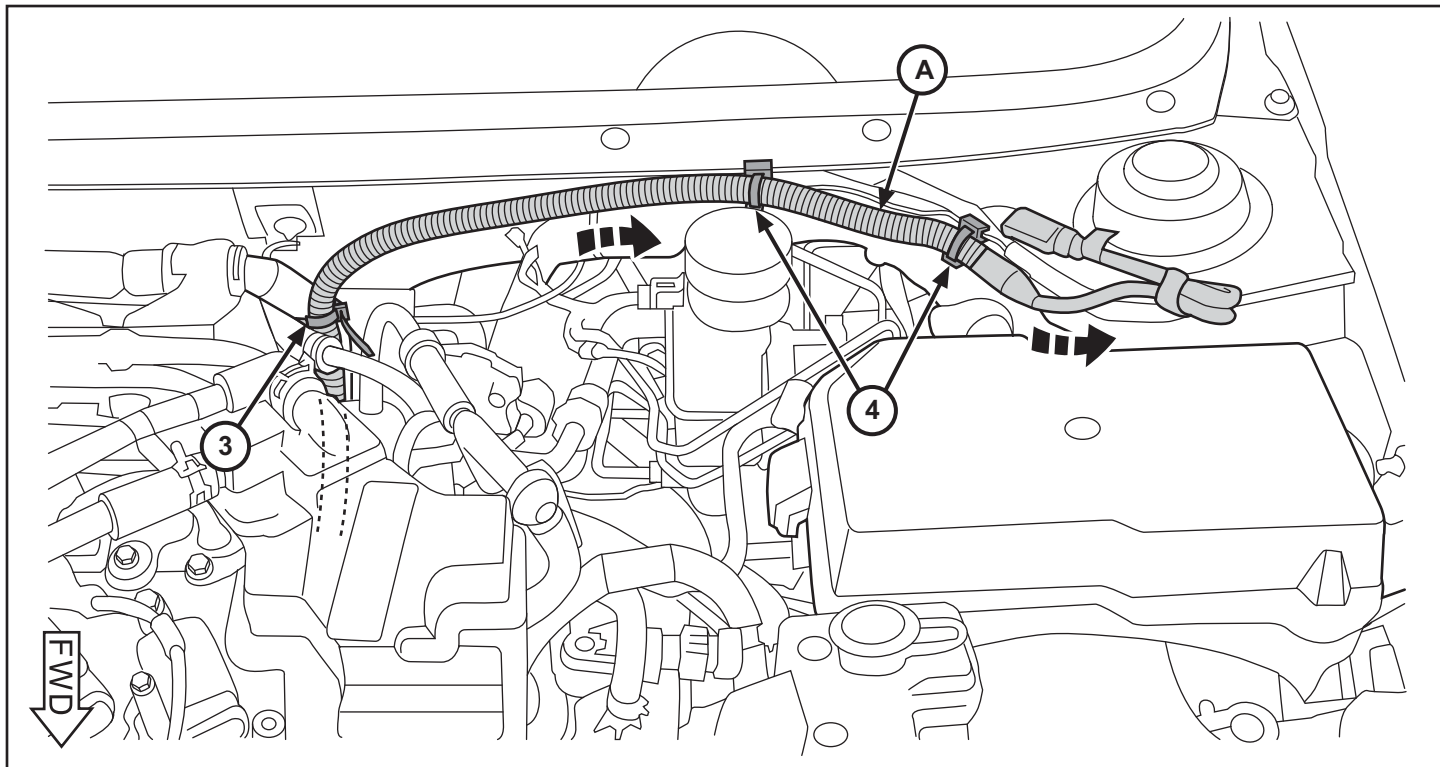

19. Contrôlez toutes les connexions et coupez l'excédent des attaches.
20. **Refaites l'emplissage du le système de refroidissement** du véhicule selon les recommandations du fabricant.
21. Élever le véhicule. **Inverser l'étape 5** pour reposer le panneau sous le moteur.
22. Abaisser le véhicule au sol. **Inverser l'étape 2** pour reposer le couvercle du moteur.



1.4L Calefactor automático de motor

www.mopar.com

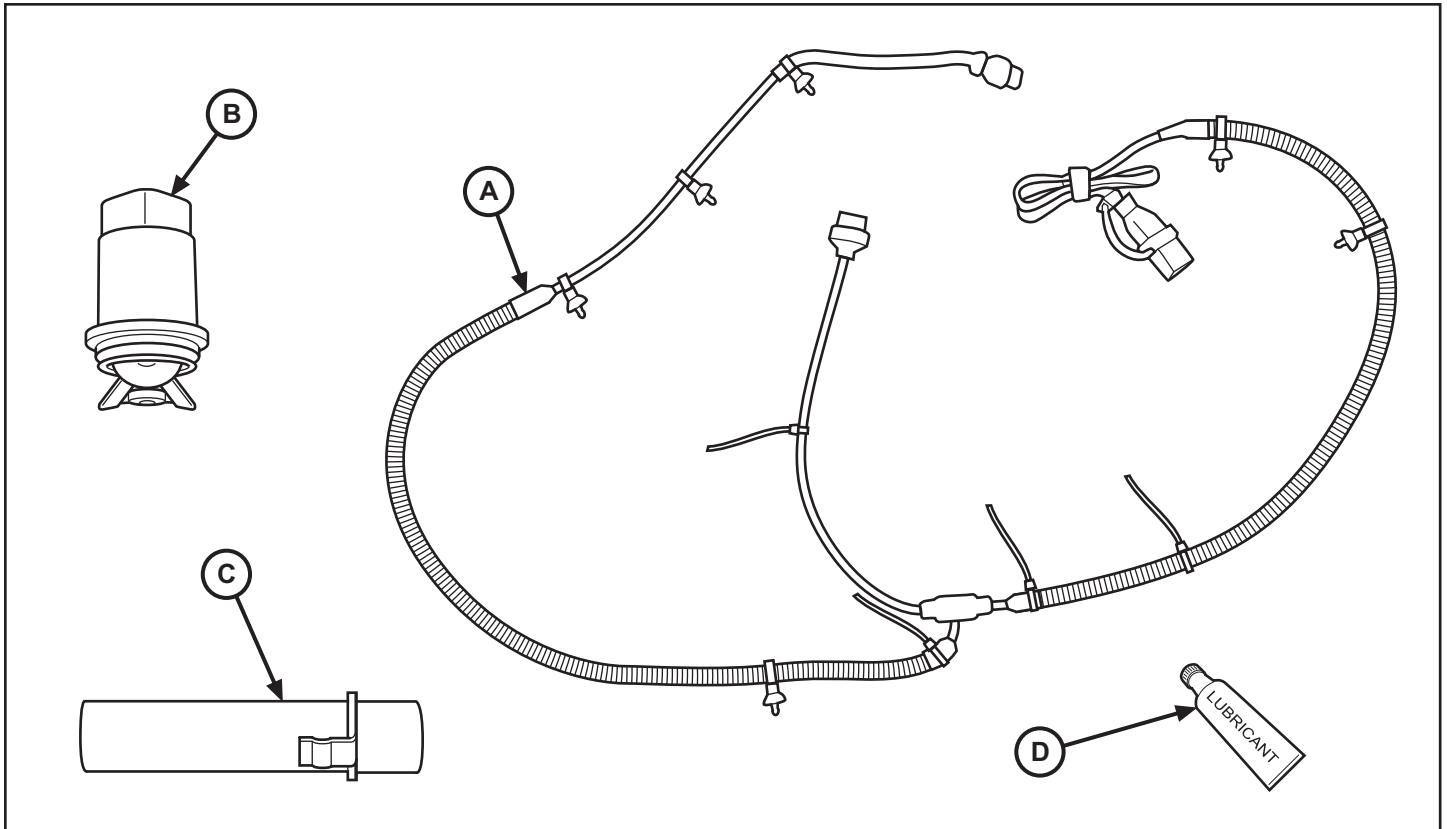

CLAVE	DESCRIPCIÓN	CANTIDAD
A	Arnés conector	1
B	Parte superior del calefactor	1
C	Parte inferior del calefactor	1
D	Lubricante	1

HERRAMIENTAS NECESARIAS

Espátula de plástico	Palanca	Martillo	Cinzel	Llave inglesa de torsión	Alicate de corte diagonal
----------------------	---------	----------	--------	--------------------------	---------------------------

1. Abra el toldo

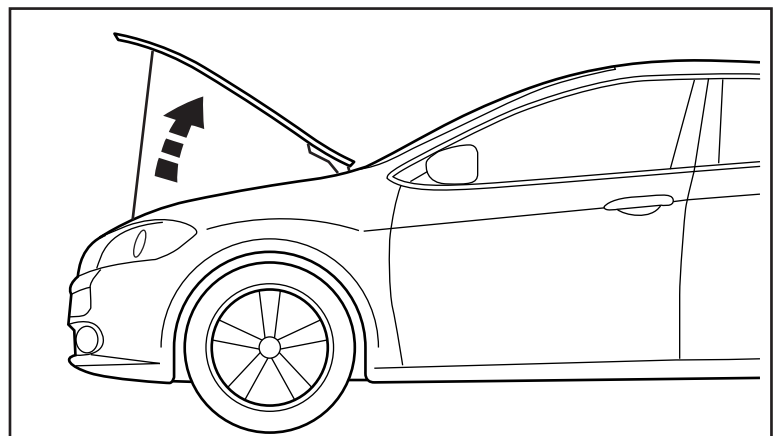

- Utilice una palanca para retirar cuidadosamente el panel superior (1) del motor.

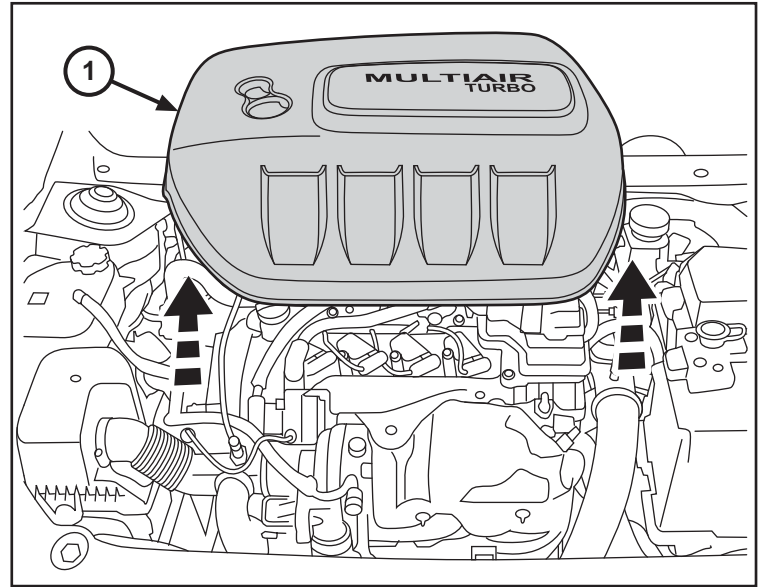

- Con cuidado coloque los extremos rojos del arnés conector (A) en la parte posterior del motor como muestra la imagen.

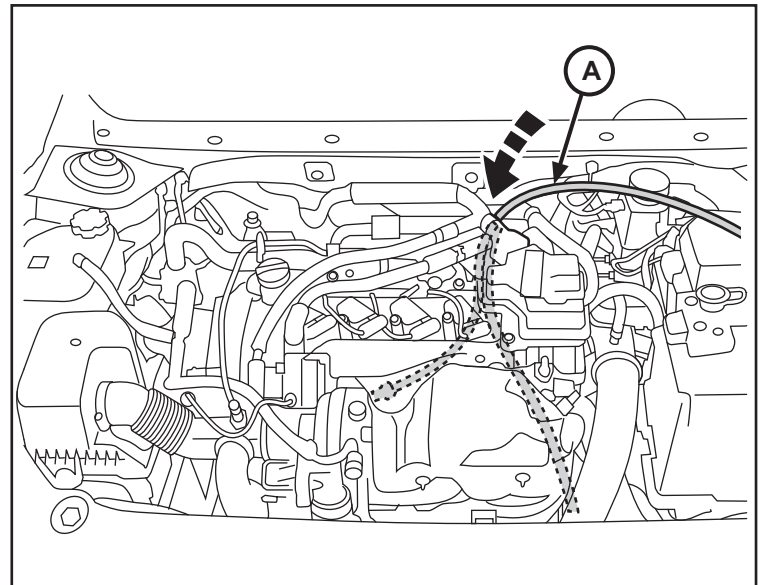

- Eleve el vehículo.

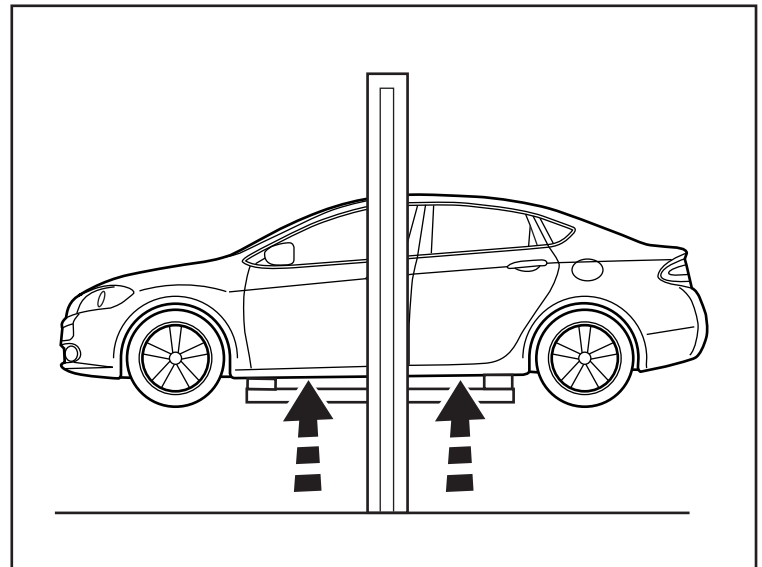

5. Desatornille los doce (12) sujetadores del panel inferior del motor. Retire el panel.

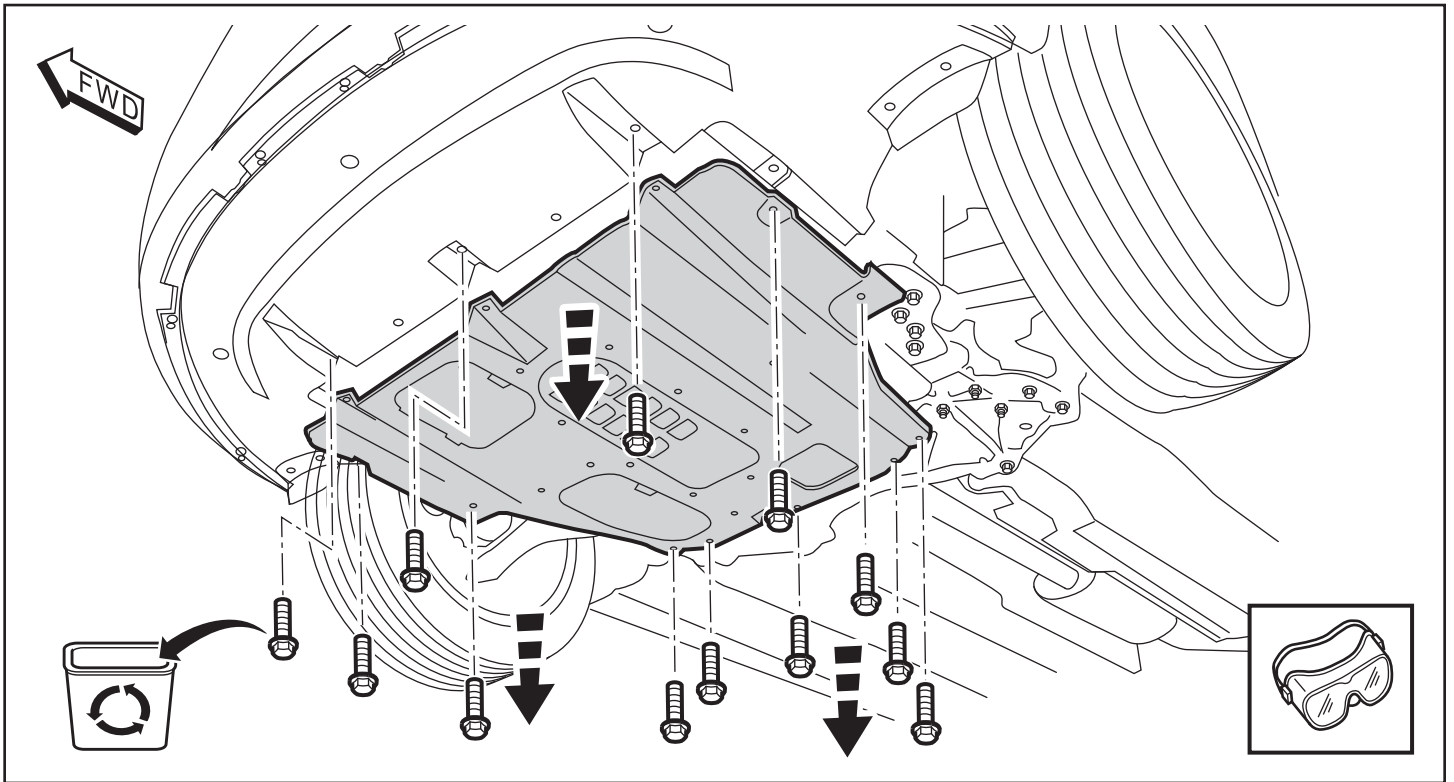

6. Purgue el sistema de enfriamiento conforme a las especificaciones de fábrica del vehículo.

7. Esta ilustración muestra las ubicaciones para el montaje de los dos elementos de calefacción (B) y (C), así como la ubicación final del arnés conector (A) en la parte posterior del motor.

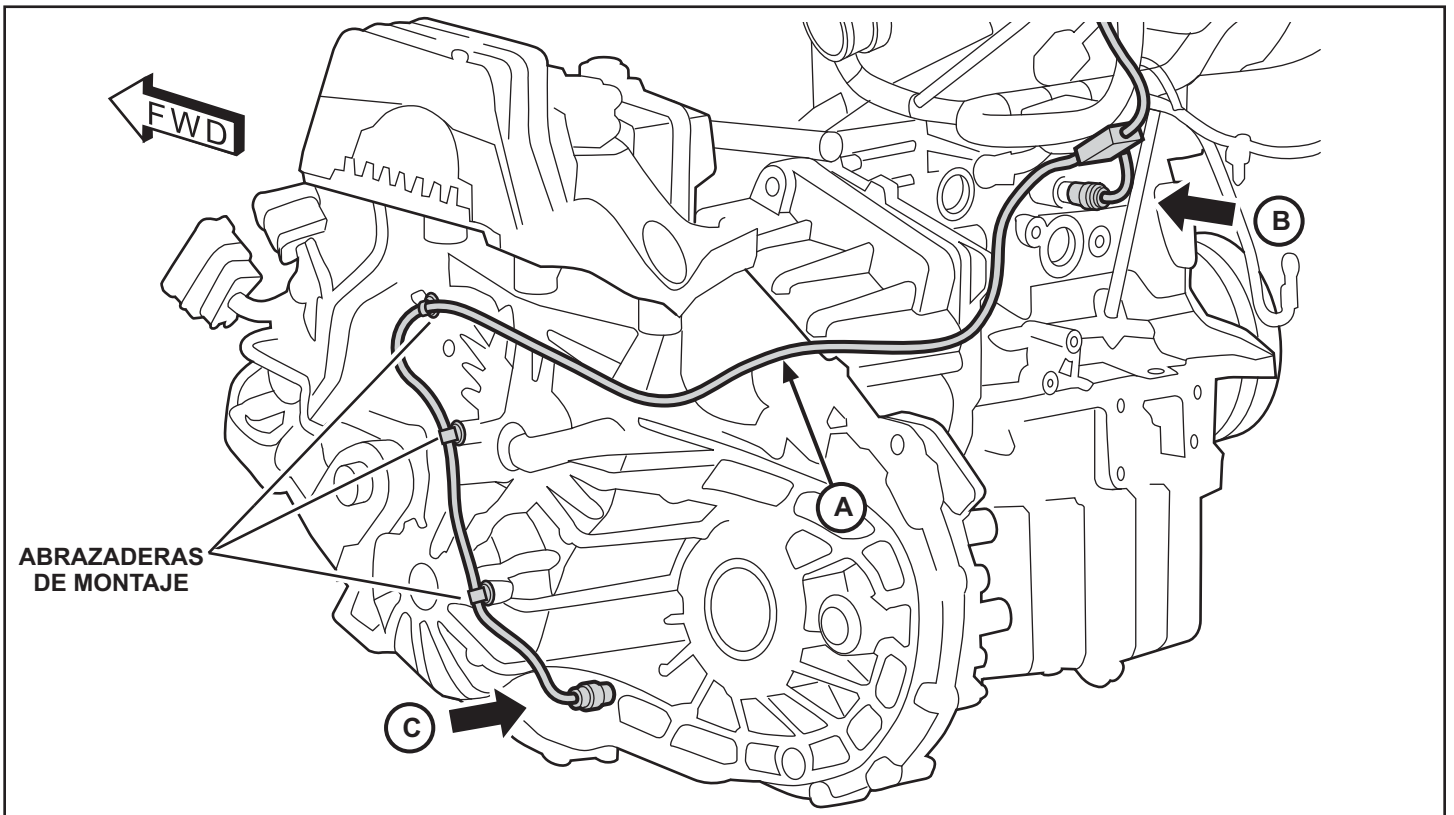

8. Mirando de abajo hacia arriba la parte posterior del motor, localice las dos tapas redondas justo sobre el eje del lado del pasajero (1).

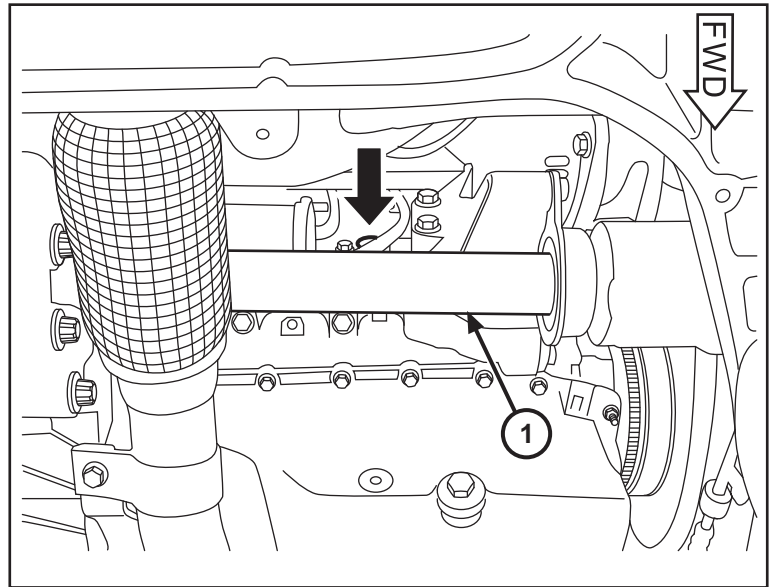

9. Con cuidado retire el tapón **SUPERIOR** (1) de la parte trasera del motor.

NOTA: El acceso al tapón es difícil. Se recomienda utilizar un martillo y un cincel o destornillador grande plano para aflojarlo. No importa dañar el tapón para retirarlo, ya que no será utilizado de nuevo.

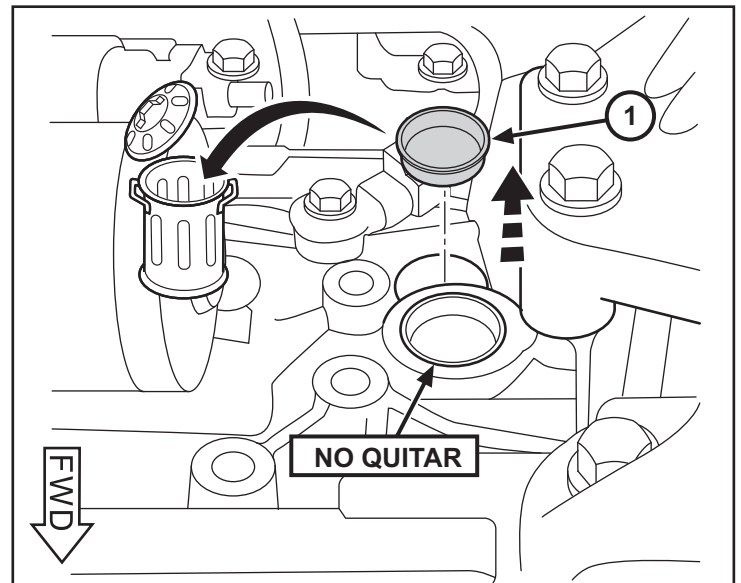

NOTA: Esta es otra vista de la parte posterior del motor. Las mangueras y otros elementos están ocultos para hacer más clara la ubicación de la tapa que debe ser retirada.

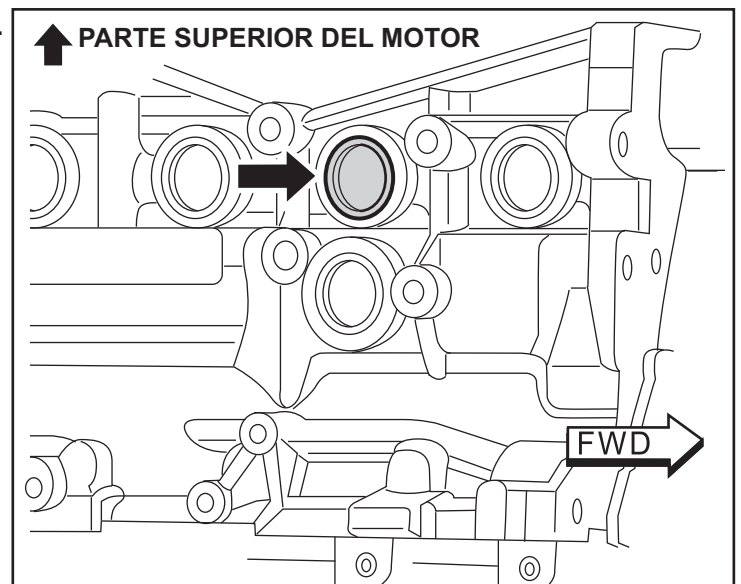

10. Inserte el calefactor (B) en la abertura.

NOTA: Asegúrese de aplicar lubricante (C) a la junta del calefactor antes de insertarlo.

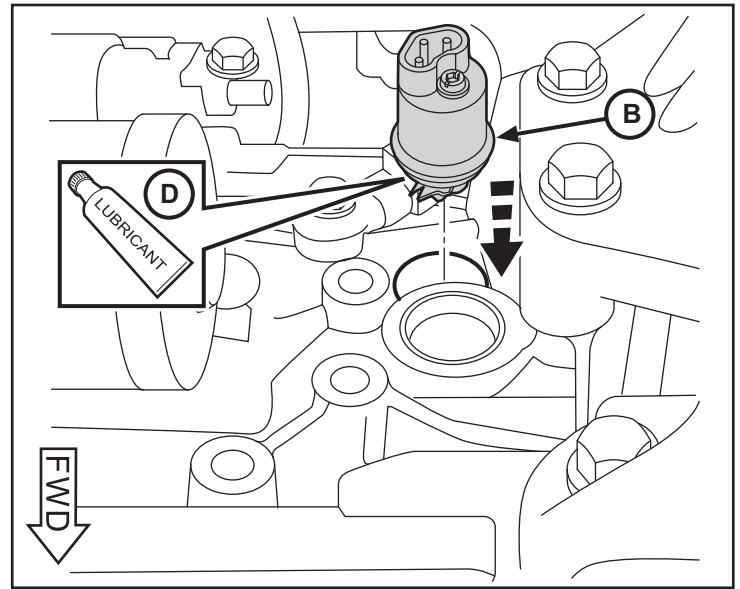
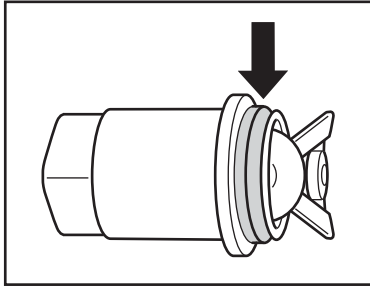

11. Coloque el calefactor (B) de manera que el tornillo de apriete (2) quede en la parte inferior para facilitar el acceso. Aplique al tornillo una presión de 20 pulgadas-libra (+/- 2 pulg.-lb) para fijar el calefactor al motor.

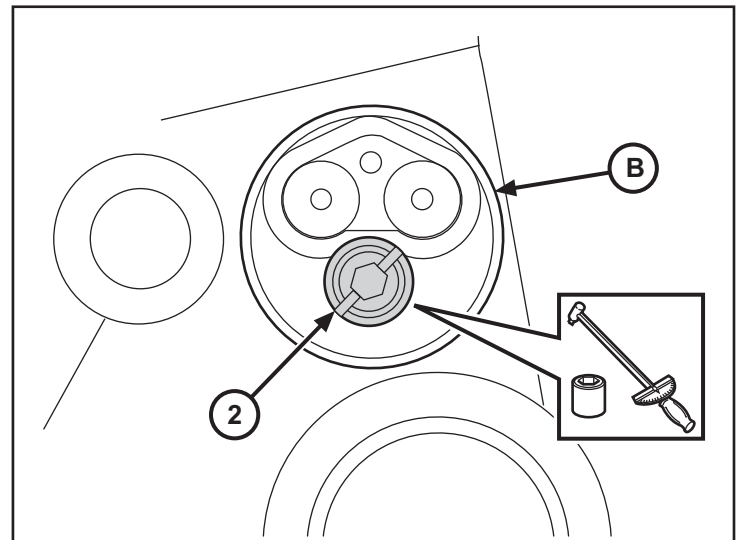

12. Conecte el enchufe rojo de la sección **más corta** del arnés conector (A) al calefactor (B).

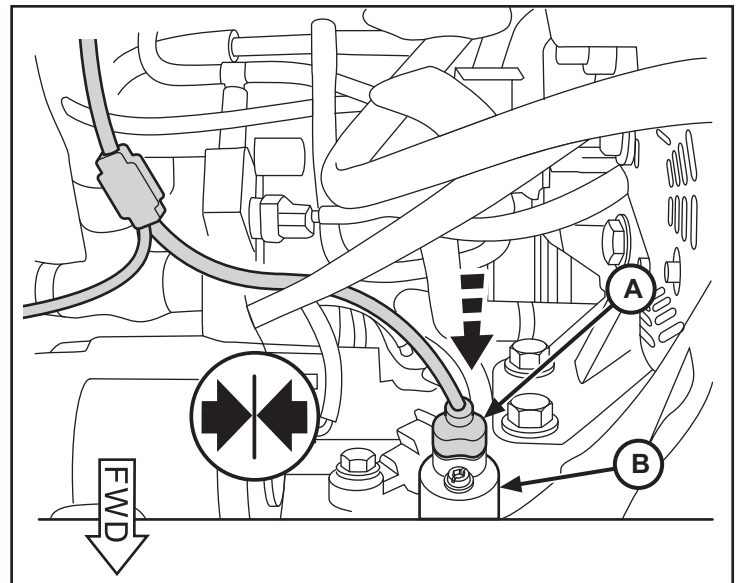

13. Coloque el arnés conector (A) a lo largo de las mangueras en la parte trasera del motor, como se muestra. Fije el conector del arnés (A) a lo largo de las mangueras con los sujetadores de cable (3) proporcionados con el arnés.

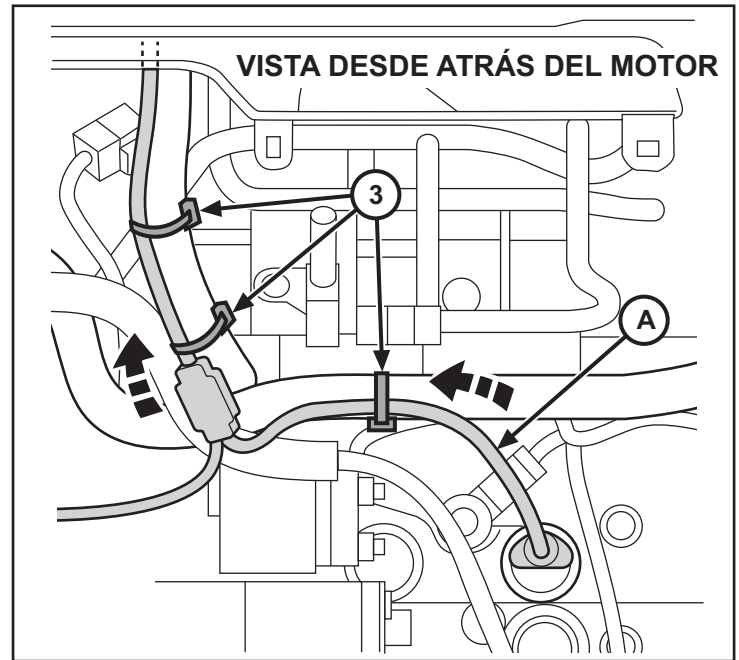

14. En el lado del conductor, localice la abertura redonda en la parte inferior izquierda de la transmisión cerca del eje. Inserte el calefactor (C) en la abertura. Presione hasta que el clip de encaje en su lugar.

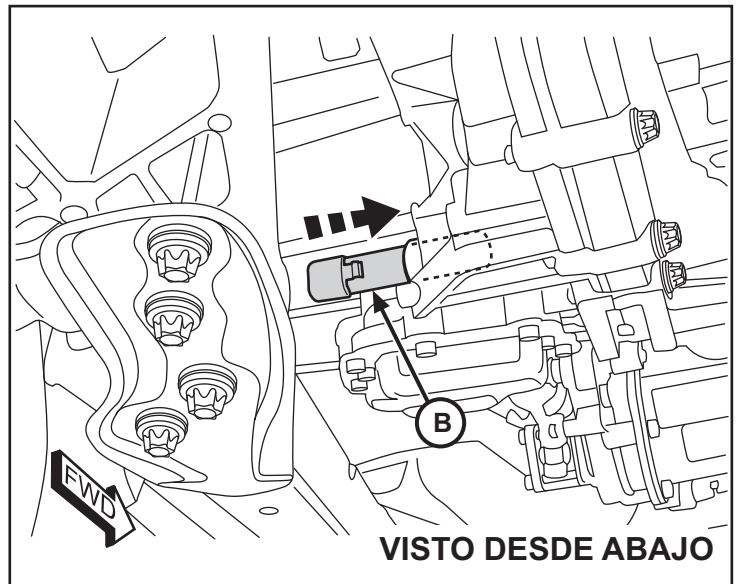

15. Coloque la sección **más larga** del arnés conector a lo largo de la parte trasera del motor. **Ver la figura 7 como referencia.** Conecte el enchufe rojo del arnés conector (A) al calefactor (C).

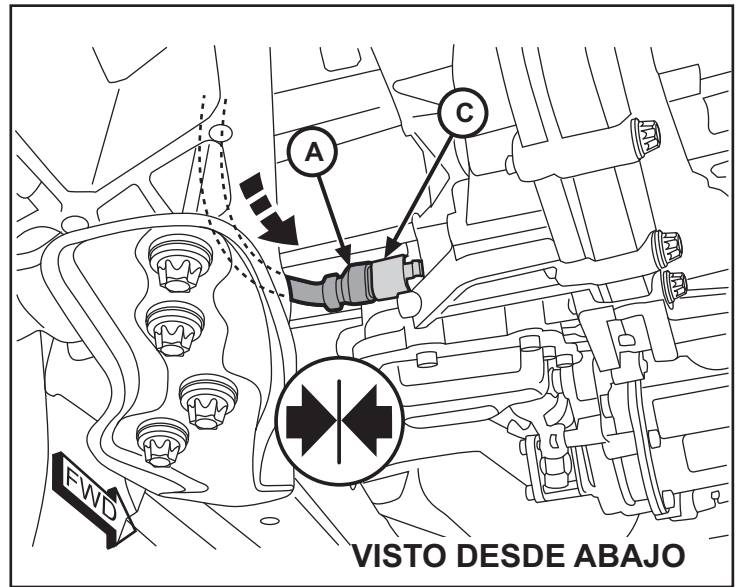

16. Fije el arnés conector (A) colocando las abrazaderas de montaje (4) proporcionadas con el arnés. Aquí se muestran dos de las ubicaciones en el lado del conductor de la transmisión. La tercera ubicación está más arriba del arnés y no puede verse en esta vista. **Ver la figura 7 como referencia.**

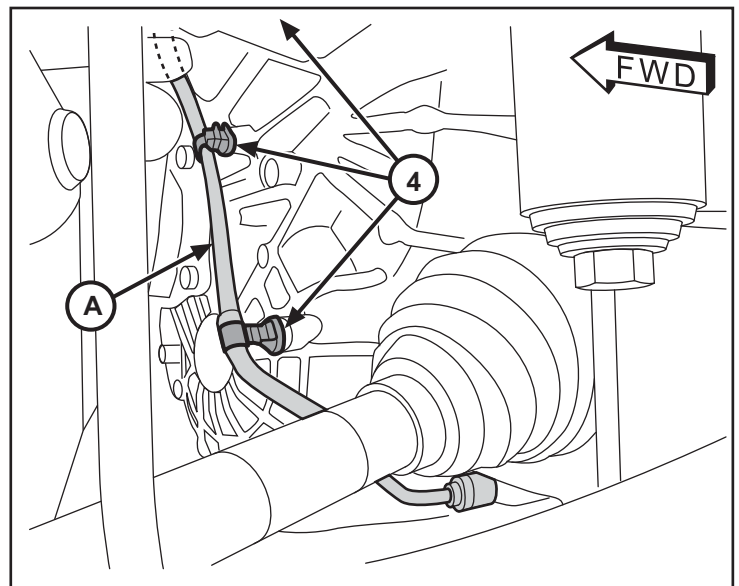

17. Baje el vehículo.

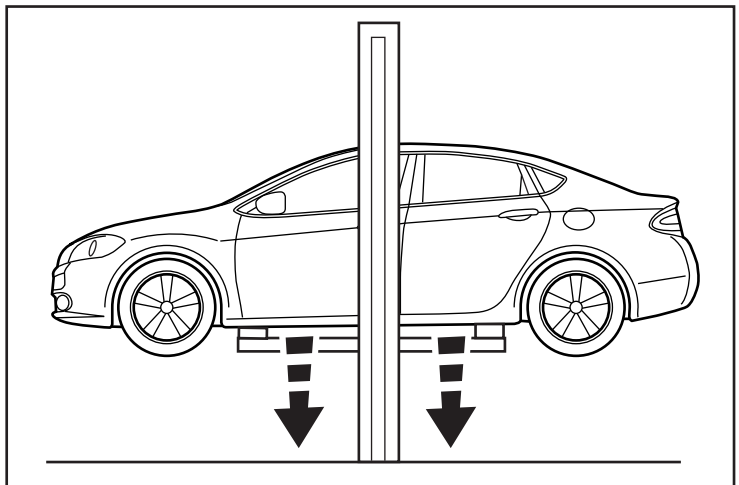

18. Coloque el arnés conector (A) en el lado del conductor del compartimiento del motor detrás de la caja de fusibles, como se muestra. Asegúrelo a lo largo del arnés del vehículo con los sujetadores de cable (3) y las abrazaderas de montaje (4) proporcionados con el arnés.

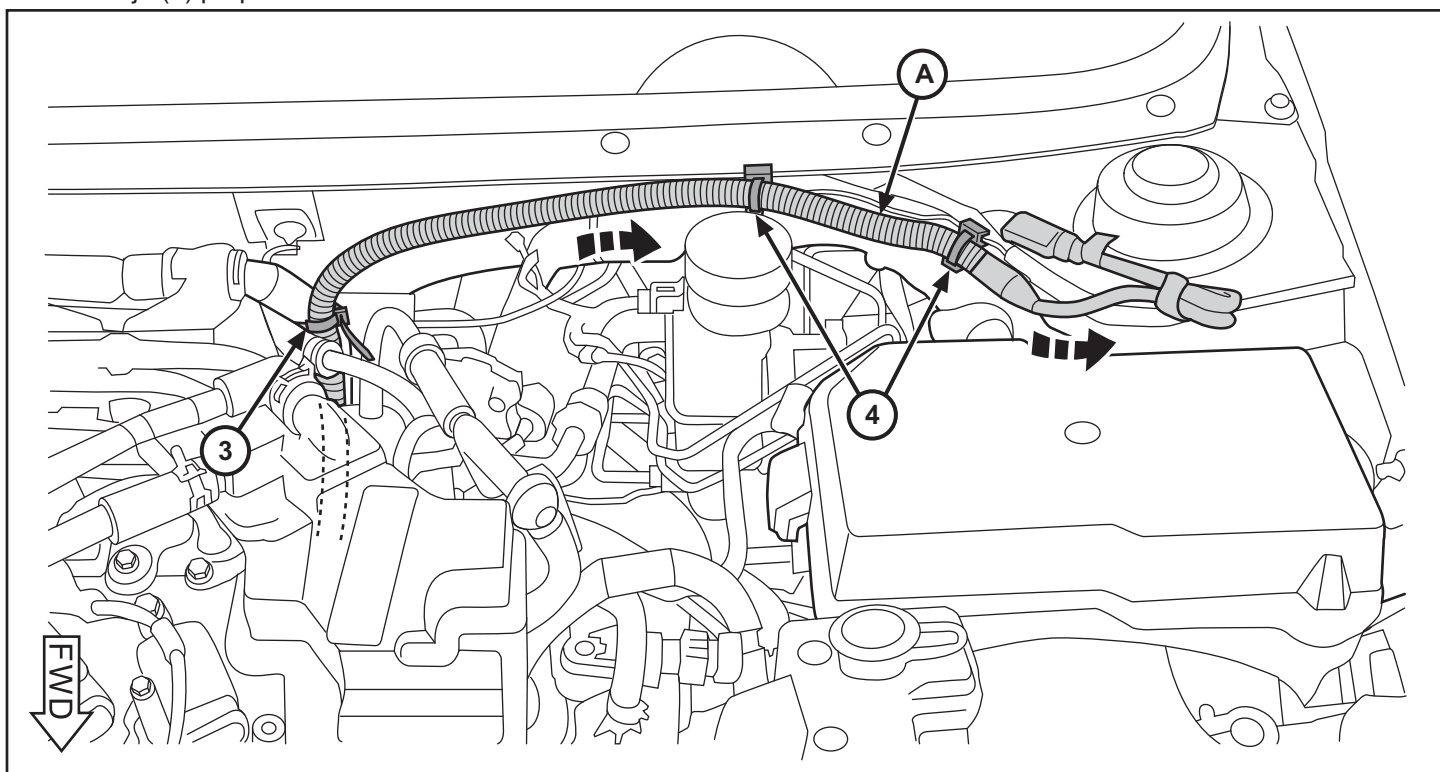

19. Revise todas las conexiones y recorte el excedente de los sujetadores de cable.
20. Rellene el sistema refrigerante conforme a las especificaciones de fábrica del vehículo.
21. Eleve el vehículo. Invierta el paso 5 para volver a instalar el panel inferior del motor.
22. Baje el vehículo. Invierta el paso 2 para volver a instalar el panel superior del motor.