

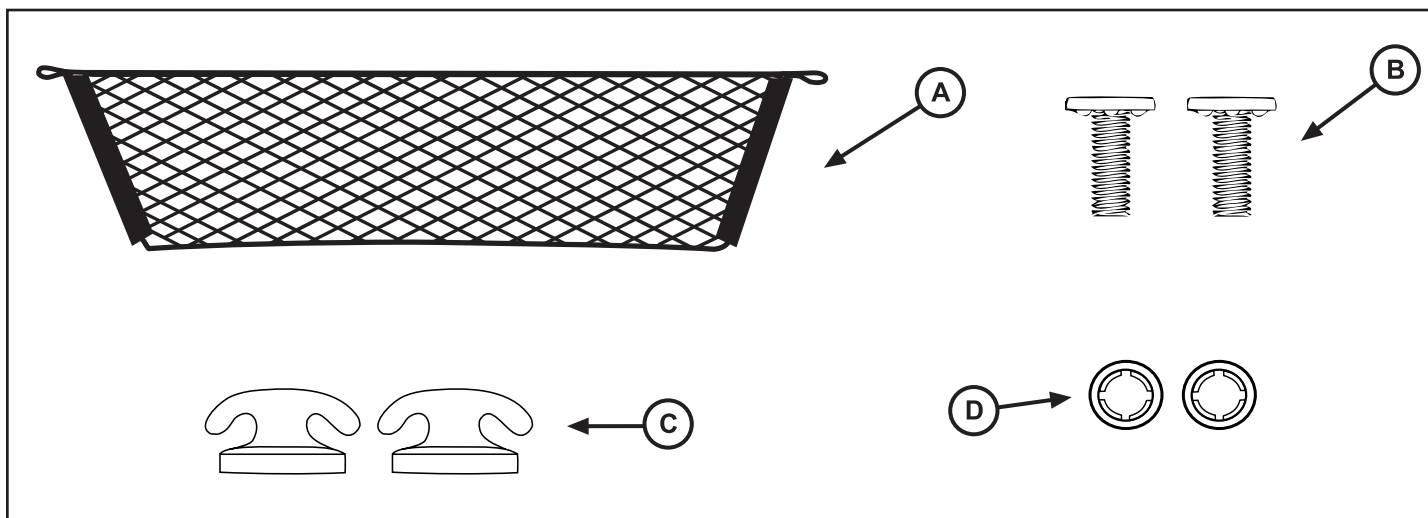

Cargo Net

DODGE DART



CALL OUT	DESCRIPTION	QUANTITY
A	Cargo Net	1
B	Weld Stud	2
C	T-Anchor	2
D	Plastic Washer	2

TOOLS REQUIRED		
	Clip Removal Tool	

CARGO NET

1. Mounting location shown.

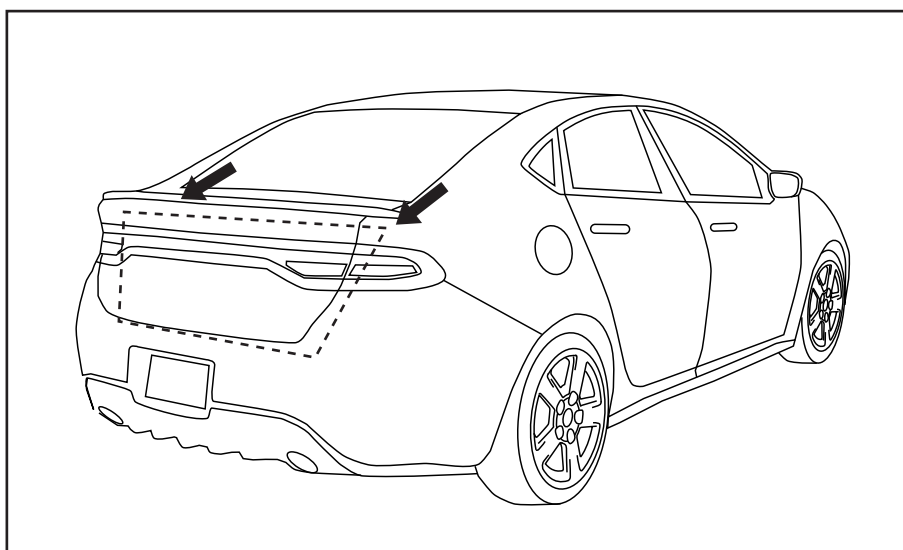

2. Locate panel fastener clip.

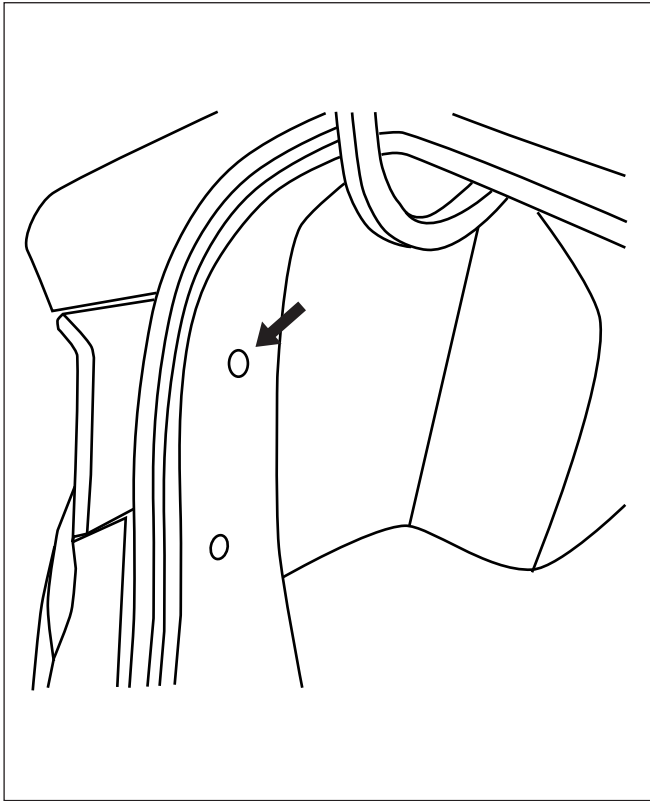

3. Using clip removal tool, remove the clip.

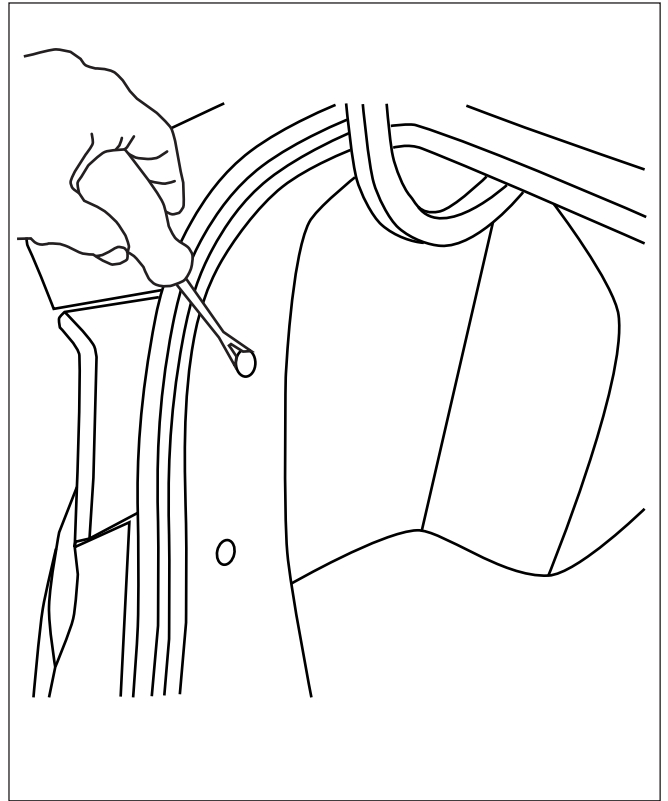

4. Pull back trunk liner to allow access to metal mounting tab.

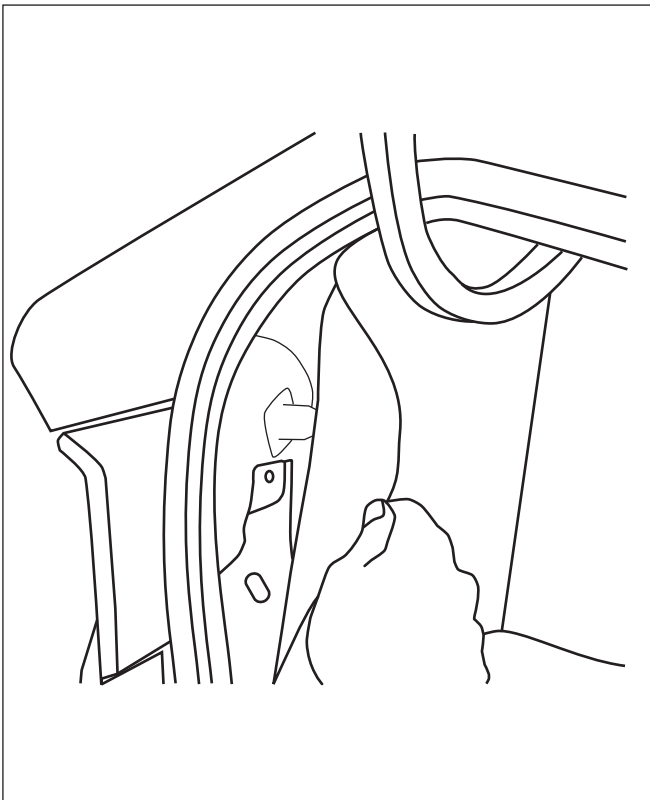

5. Insert weld stud from behind and push plastic washer over threaded end.

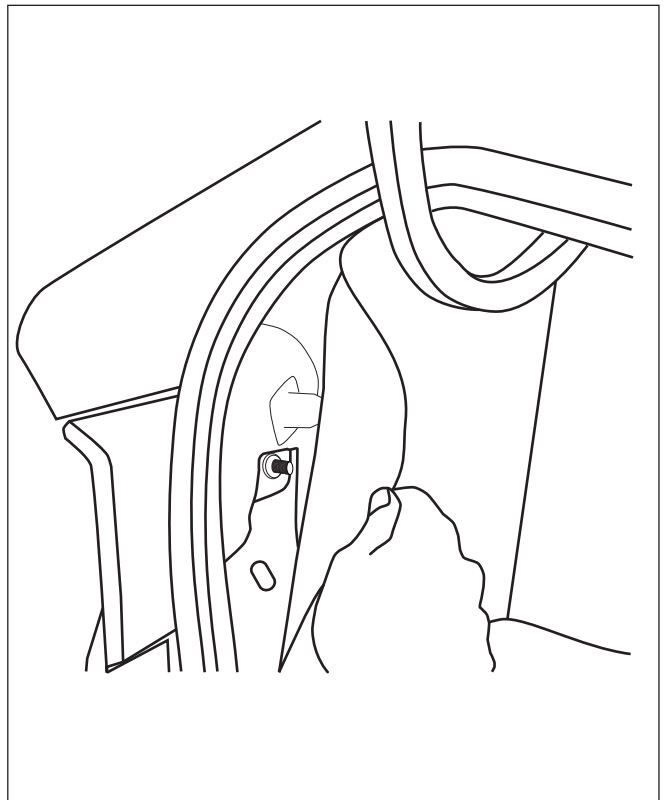

6. Carefully line up the hole in the trunk liner and pull it over the installed weld stud.

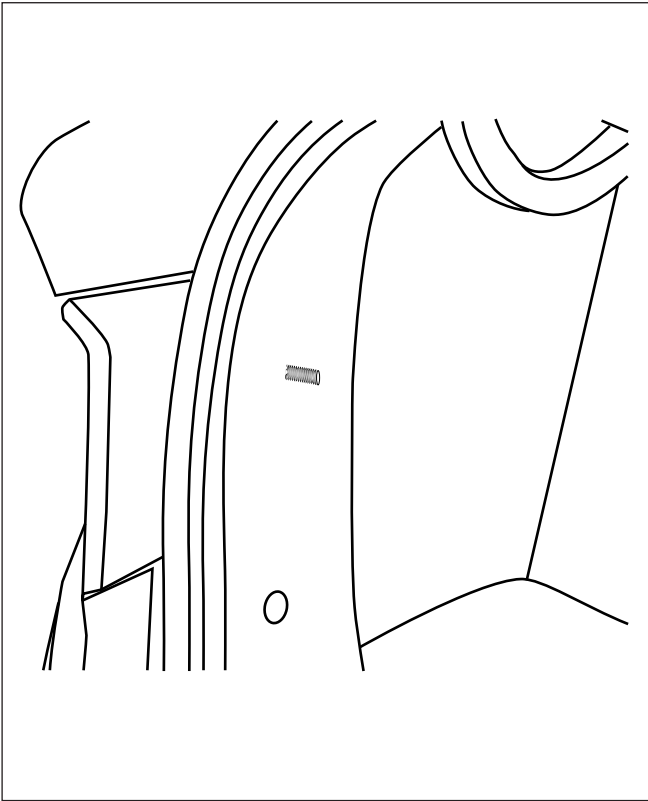

7. Screw T-Anchor onto the weld stud. Check for gaps between hardware and trunk liner.

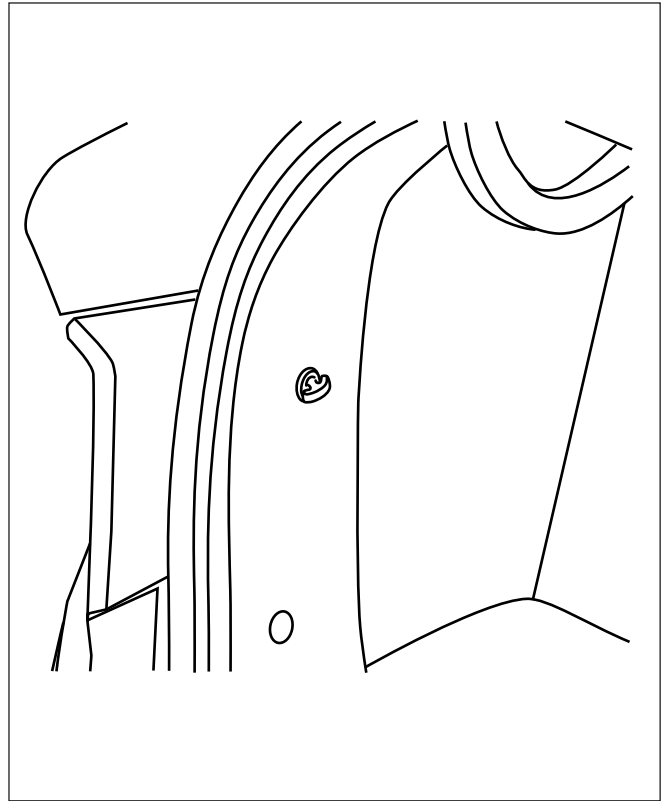

8. Attach net loop to horizontal T-Achor.

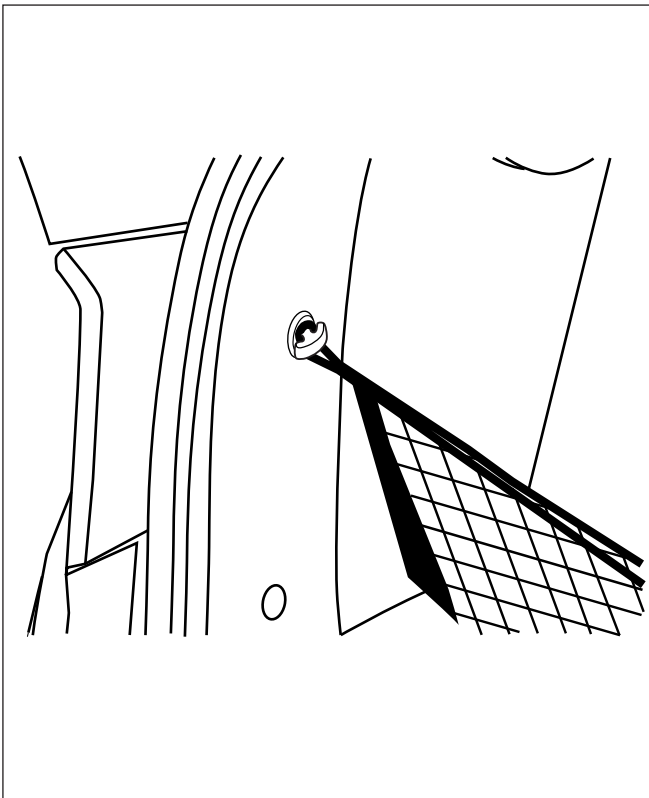

9. Installed net.

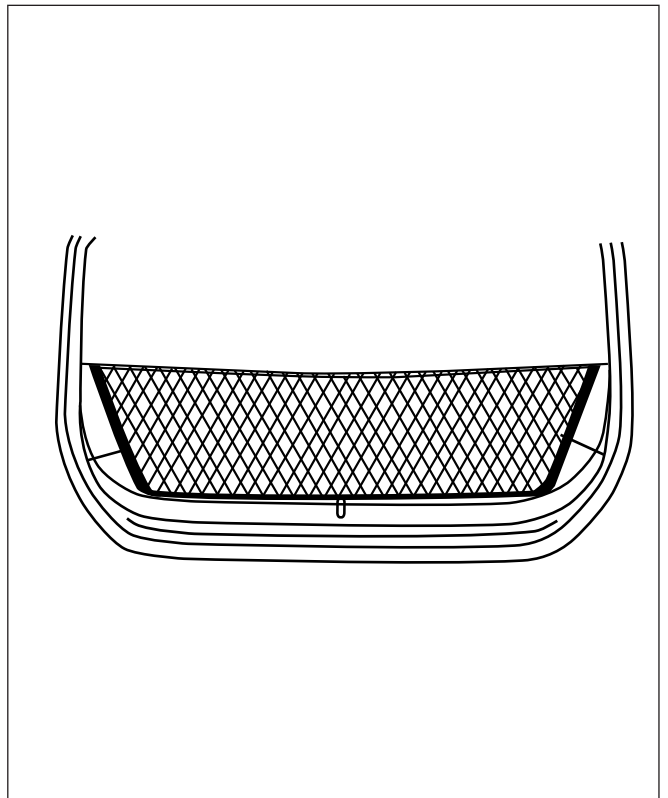



Filet d'Arrimage

DODGE DART

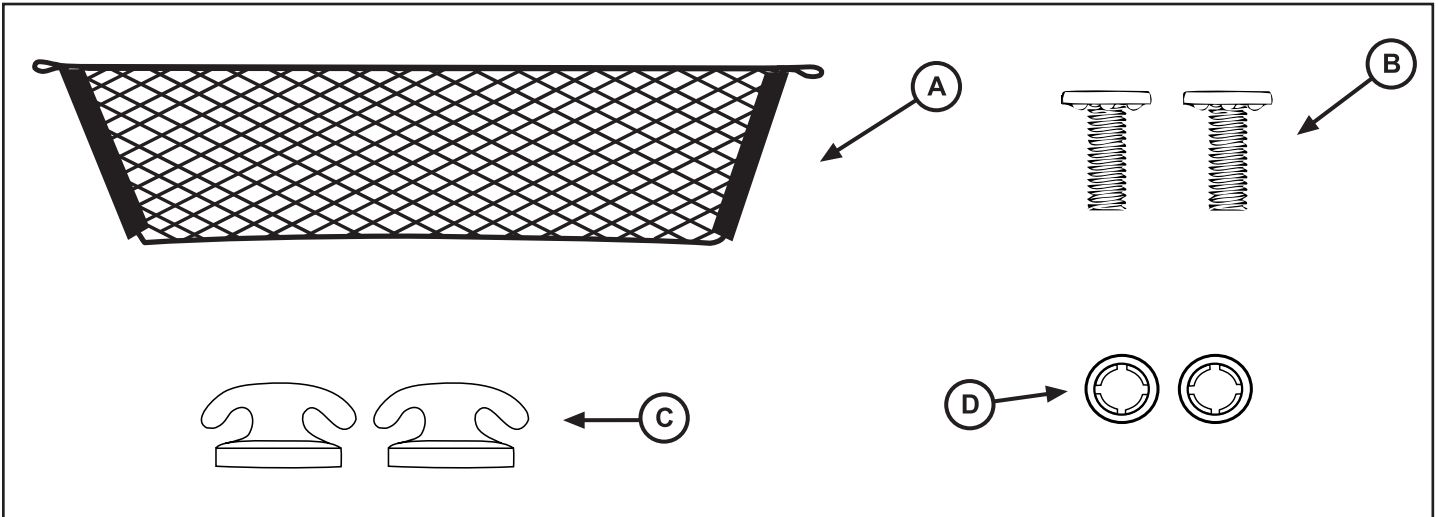

RÉFÉRENCE	DESCRIPTION	QUANTITÉ
A	Filet d'Arrimage	1
B	Boulon d'Ancrage	2
C	T-Ancre	2
D	Rondelle en Plastique	2

OUTILS REQUIS

Outil de suppression de clip

FILET D'ARRIMAGE

1. Emplacement de montage indiqué.

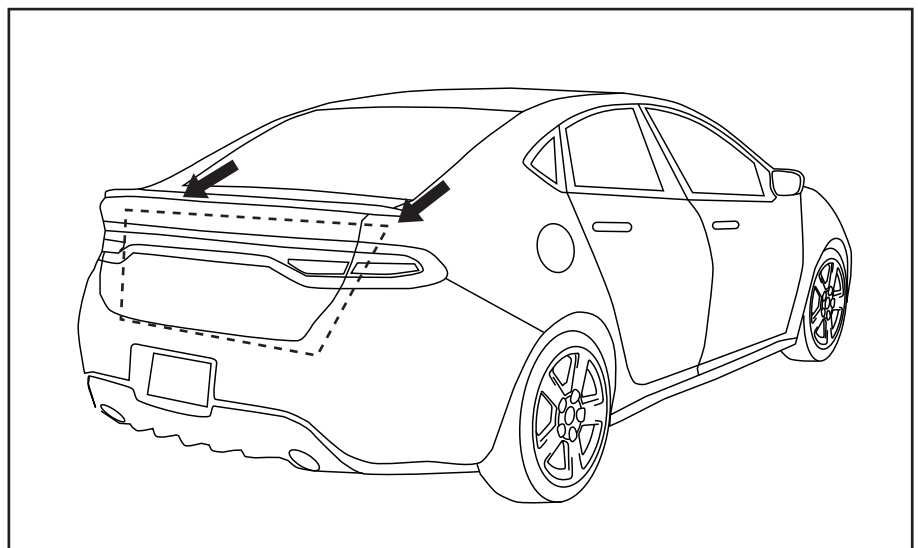

2. Trouver d'agrafes du panneau.

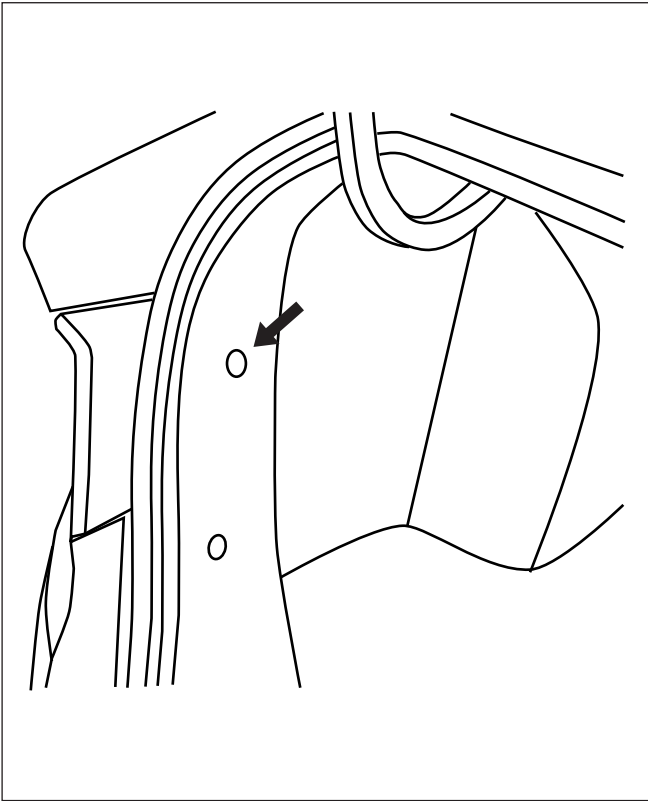

3. Utiliser L'outil de suppression pour supprimer fixation.

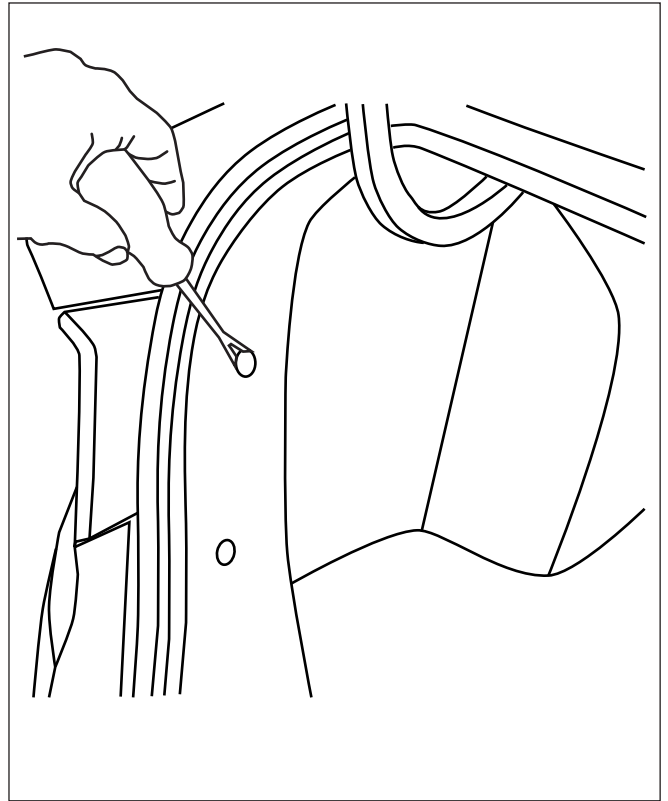

4. Tirez le panneau arrière pour accéder à l'onglet de montage métallique.

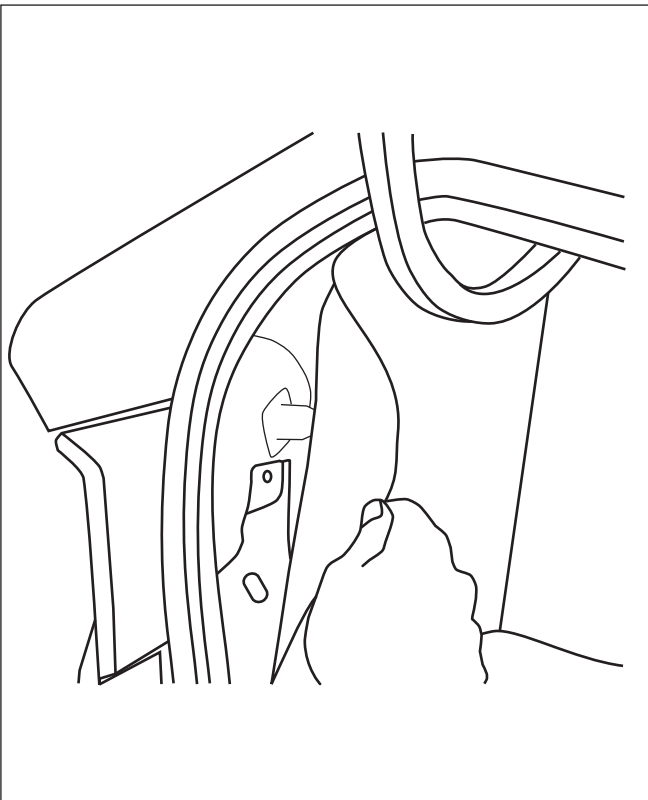

5. Insérez le boulon d'ancrage de l'arrière et pousser la rondelle plastique sur la vis boulon.

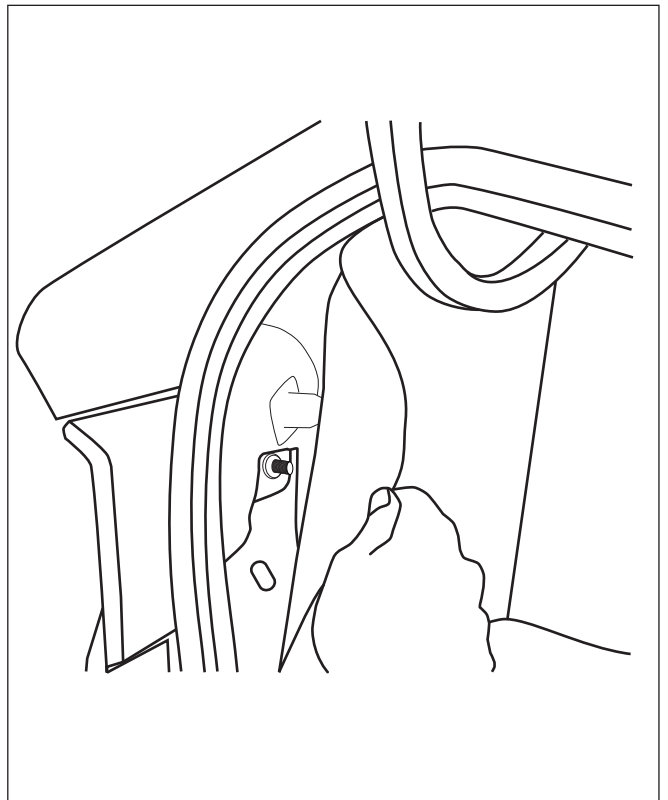

6. Aligner le trou dans le pannedu de coffre avec boulon d'ancrage et ré-assembler.

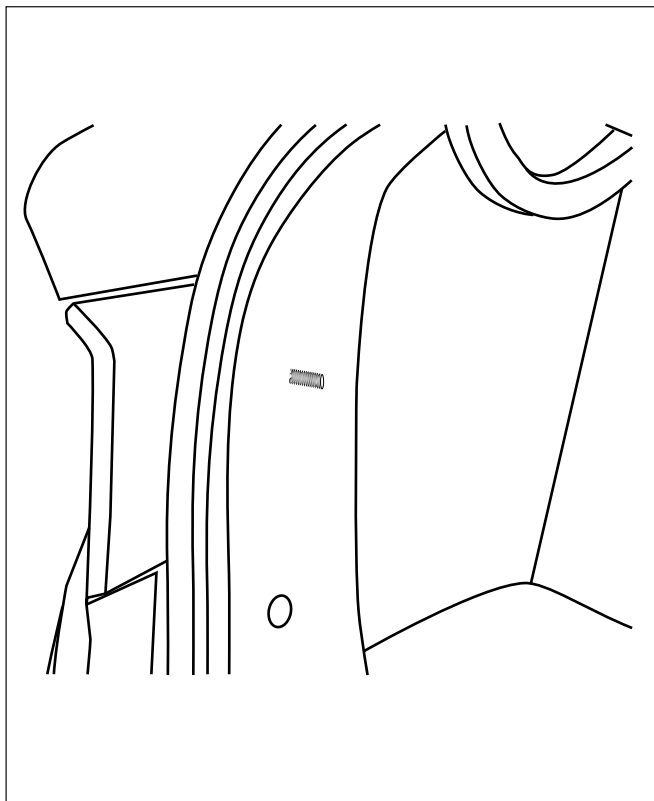

7. Vis t-ancrage surle boulon d'ancrage. Vérifier les écarts entre le matériel et la panneau.

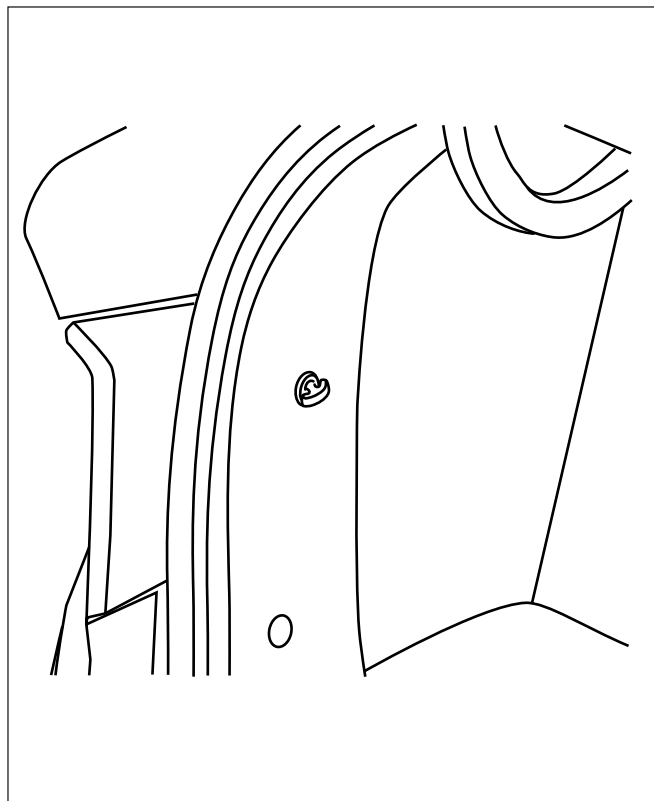

8. Attacher la boucle nette à l'horizontale t-ancre.

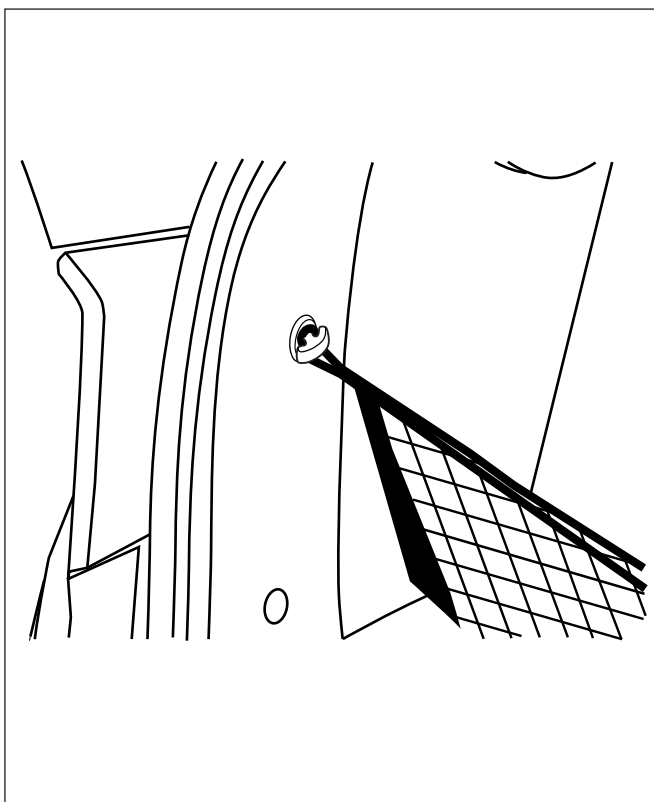

9. Filet installé.

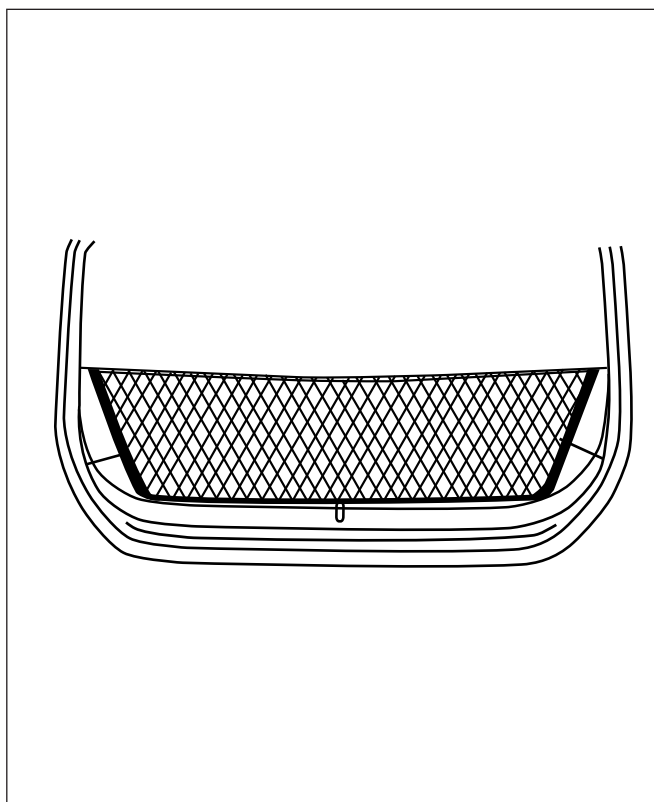



Red de Carga

DODGE DART

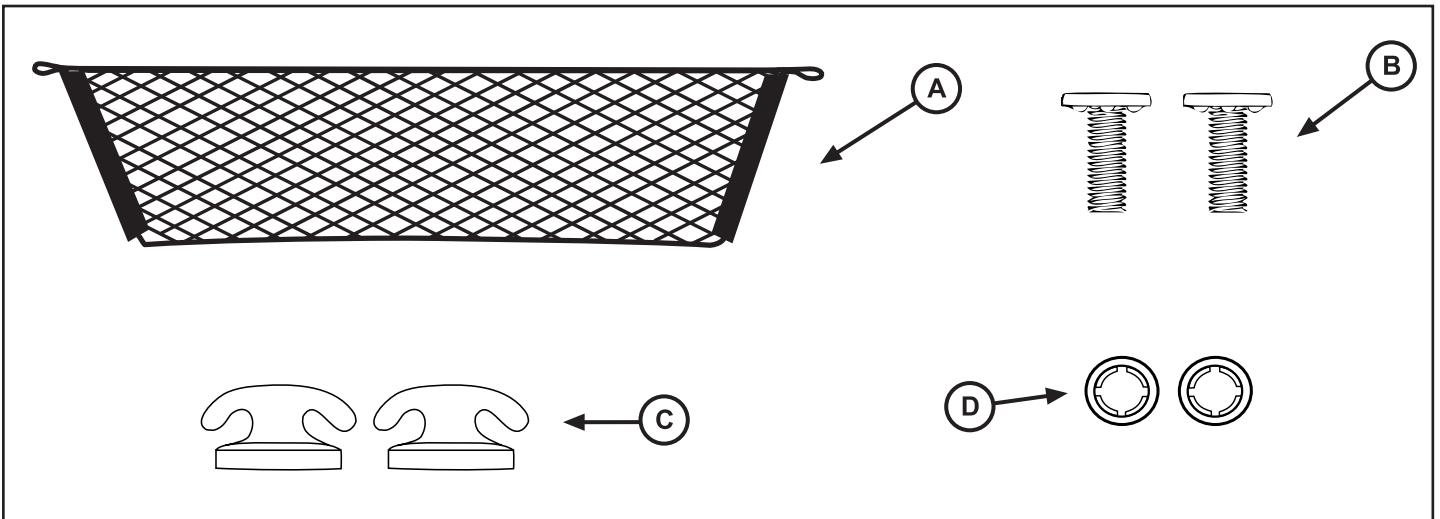

ELEMENTO	DESCRIPCIÓN	CANTIDAD
A	Red de Carga	1
B	Apego Perno	2
C	Ancla de Plástico	2
D	Arandela de Plástico	2

HERRAMIENTAS NECESARIAS

Herramienta de eliminación para el clip

RED DE CARGA

1. Imagen de la ubicación del montaje.

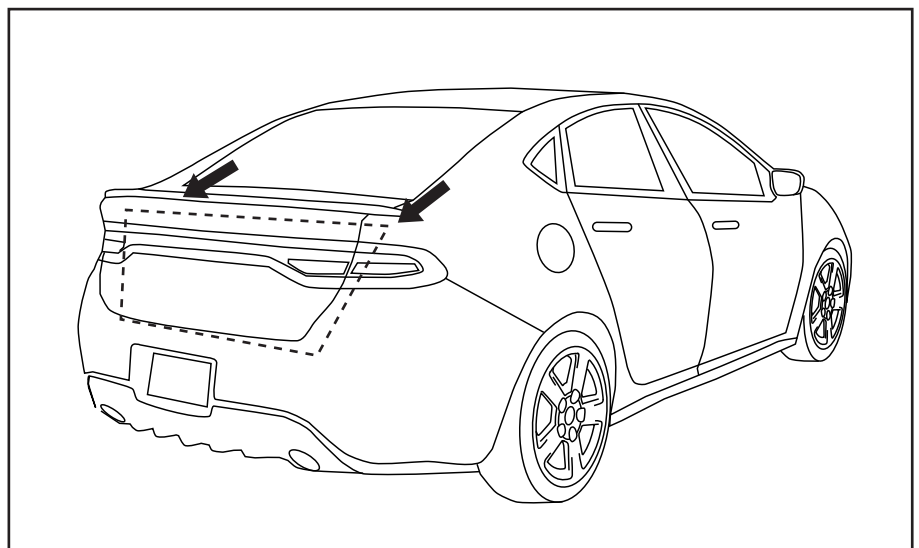

2. Encontrar clip de fijación del panel.

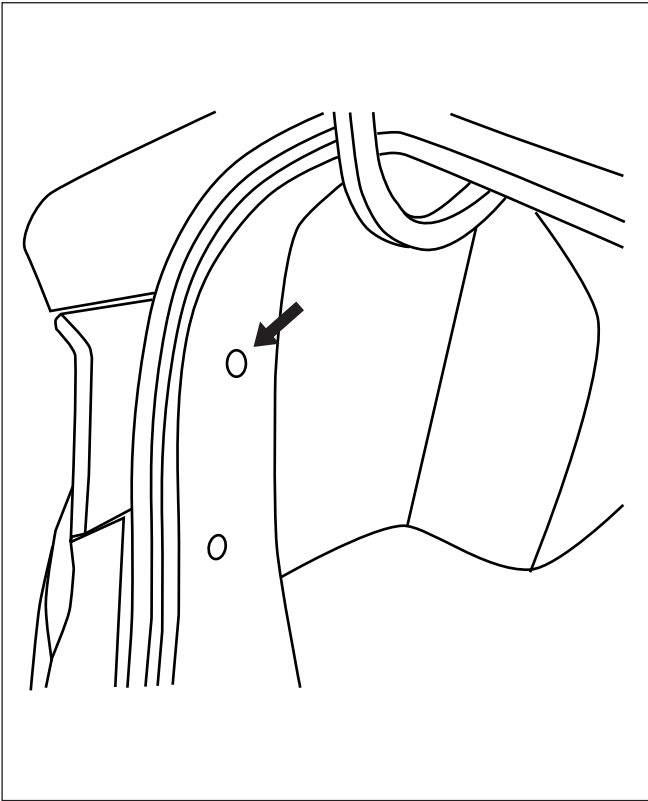

3. Eliminar el clip de sujecion usando la herramienta de eliminacion de.

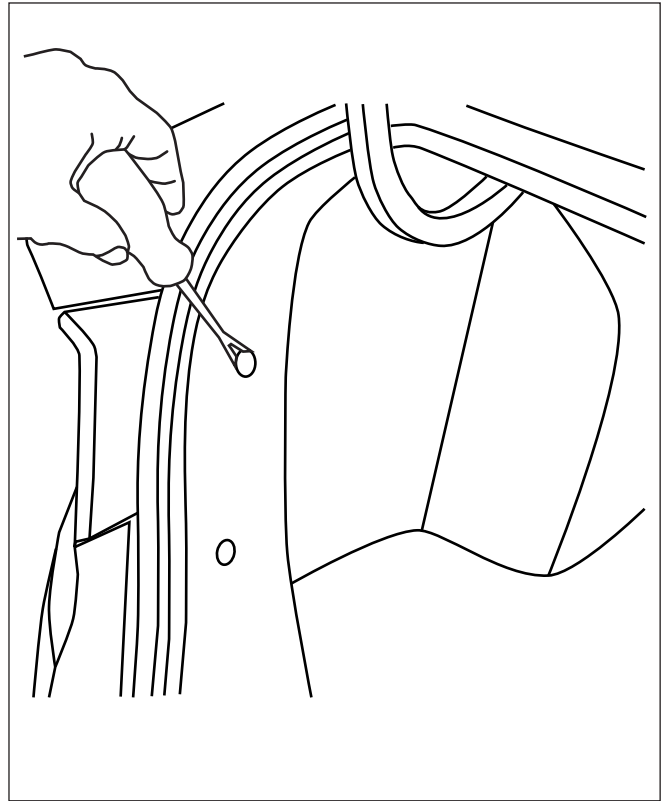

4. Tirar del panel para acceder ala pestaña de montaje de metal.

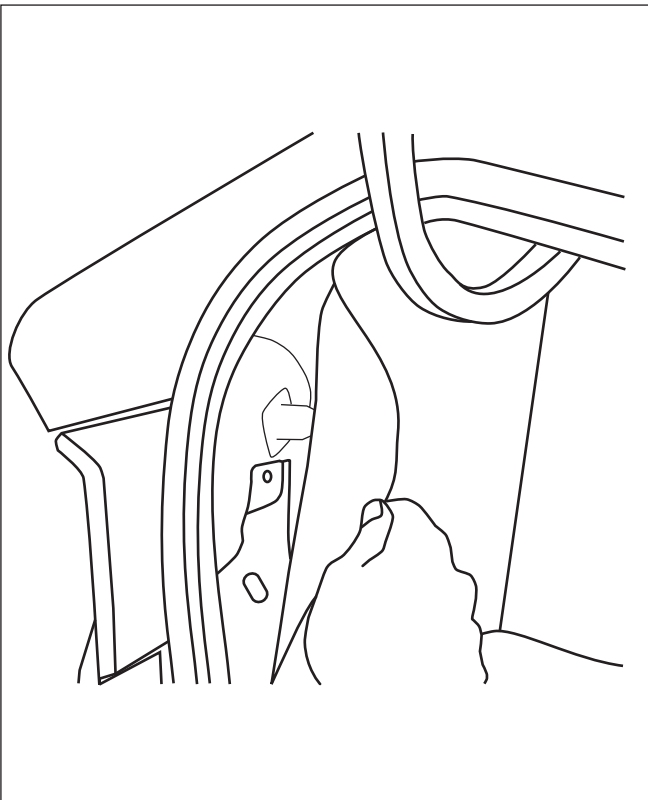

5. Inseréz le boulon d'ancrage de l'arriére et pousser la rondelle plastique sur la vis boulon.

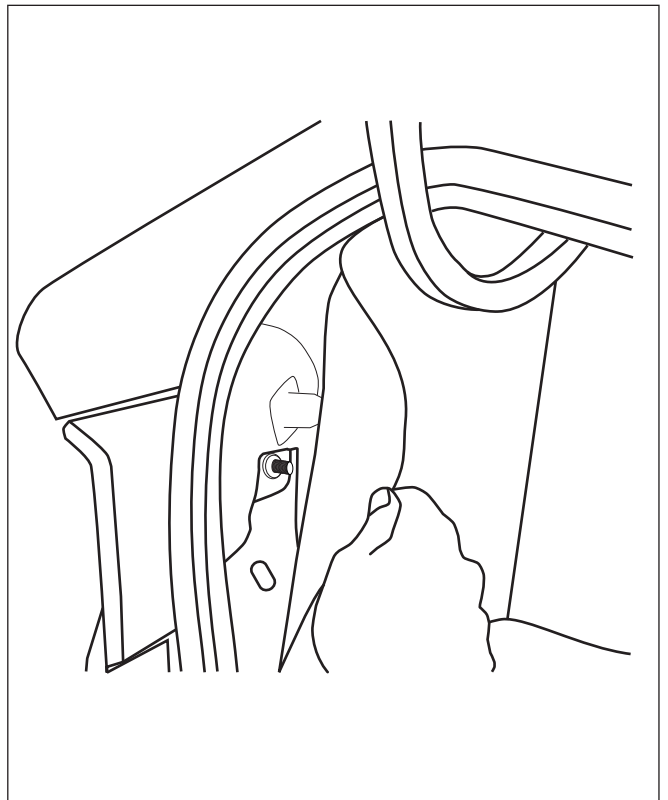

6. Volver a montar el panel sobre el anclaje del perno.

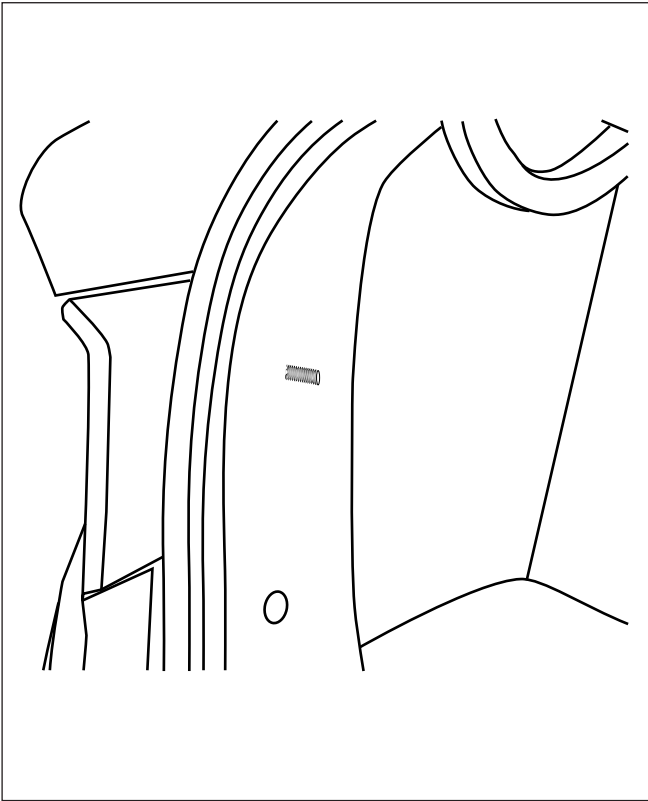

7. El tornillo de anclaje de plástico en el perno de anclaje. Comprobar si hay diferencias entre el hardware y el panel.

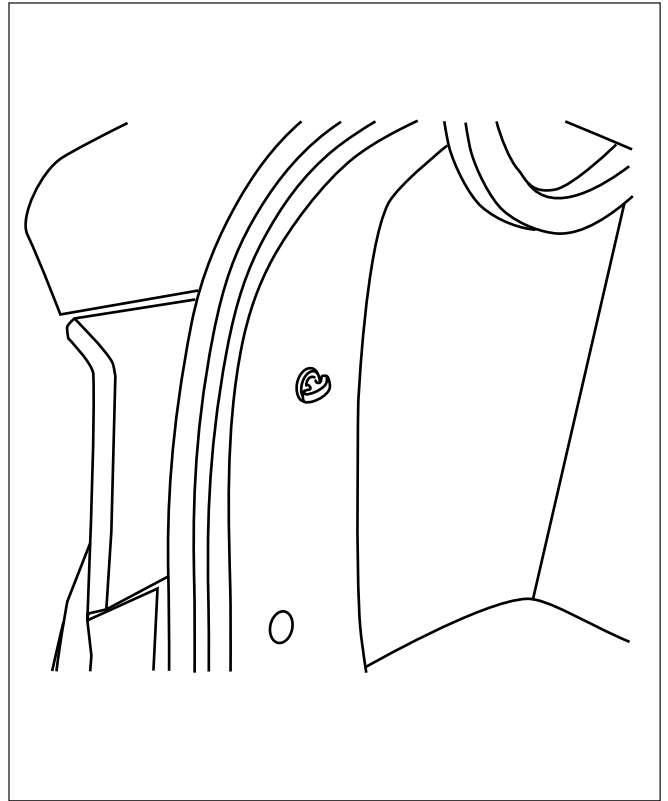

8. Coloque el bucle de red para anclaje de plástico horizontal.

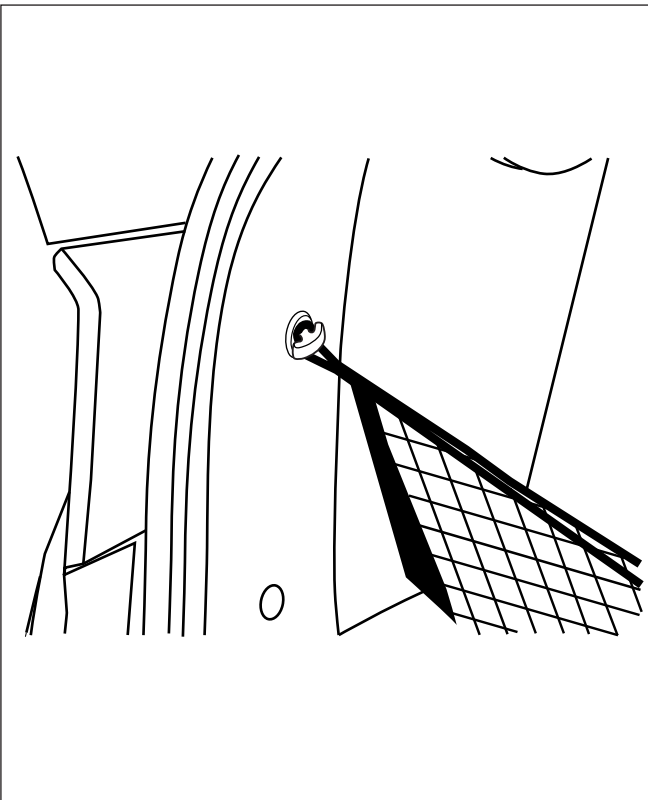

9. De carga neta instalada.

