



Jeep Compass, Jeep Patriot Trailer Hitch

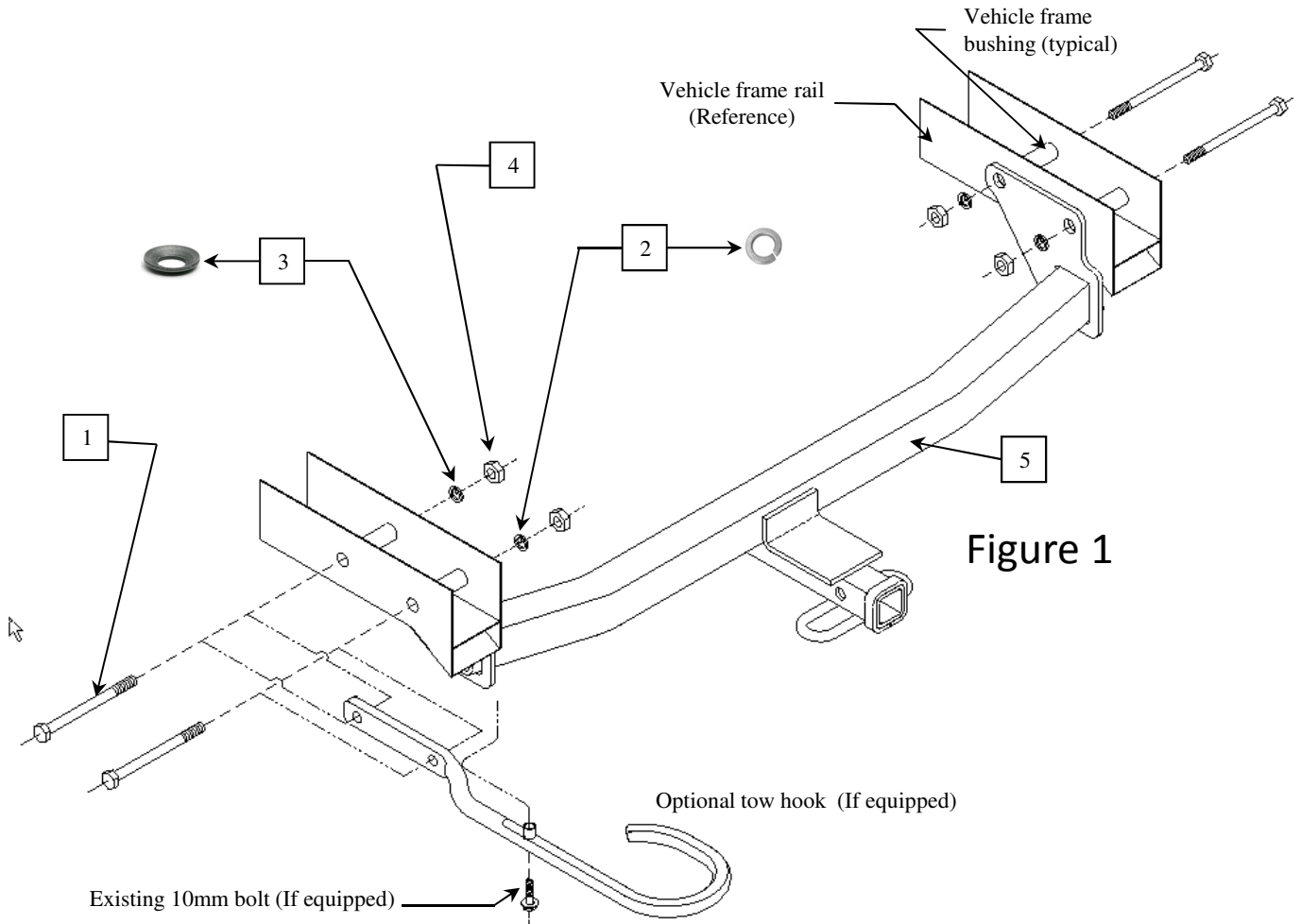
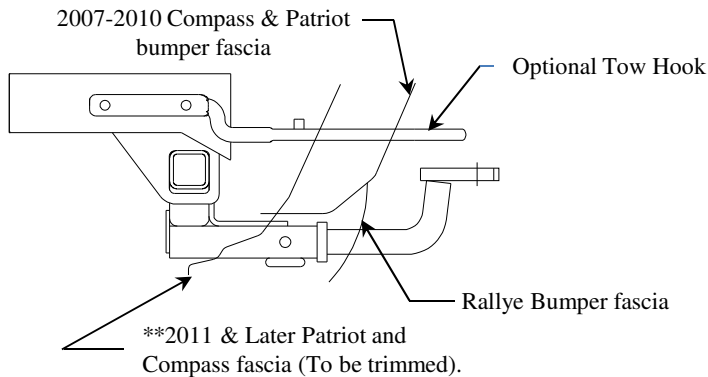

Figure 1

Call Out	Description	Quantity
1	5/8"-11 X 4-1/2" Hex Bolt	4
2	5/8" Lock Washer	2
3	5/8" Conical Washer	2
4	5/8"-11 hex Nut	4
5	Hitch Assembly	1
6 (Not Shown)	Instruction Sheet	1

Do Not Exceed Lower of Towing Vehicle Manufacturer's Rating

Hitch Type	Max Gross Trailer WT (LB)	Max Tongue WT (LB)
Weight Carrying Ball Mount	2000 (909 kg)	200 (90 kg)

Fig. 2 Hitch Shown In Proper Position**Equipment Required:****Fastener Kit:** 36423F**Wrenches:** 15/16", 16mm-tow hook option**Drill Bits:** 5/8" Patriot *with* optional tow hook only.**Cutting Tool:** Compass Rallye and 2011 & later Patriot and Compass.**Note 1.****Patriot with optional tow hook**

On Jeep Patriot with optional tow hook on Driver's side it is necessary to remove tow hook.

Check with vehicle owner

to see if they want tow hook reinstalled. To reinstall hook it is necessary to press/drive existing knurled neck bolts out of hook and drill out with 5/8" drill.

Reinstall hook by using supplied 5/8" bolts following steps below.

Step by Step Instructions

- Place 5/8 hex bolts into vehicle bushings from the outboard side of the vehicle frame rails. Leave bolt ends flush with the inboard side of frame rails.
- Raise hitch into position and push 5/8 hex bolts through hitch frame brackets to support the hitch.
- Attach remaining hardware as shown above.
- On Compass Rallye Package only.** Use template (Appendix A) and hitch receiver tube as a guide, cut a 3 1/2" (89mm) wide by 4" (102mm) high piece out of bumper fascia to allow clearance for ball mounts. See Figure 3.
- Tighten all 5/8-11 fasteners with torque wrench to 100 Lb.-Ft. (136 N*M)

Additional Steps – Compass Rallye, 2011 and later Jeep Patriot and Compass

- If vehicle has **optional tow hook** see Note 1, above. For **Compass Rallye** see Note 2 and Figure 2. **Check with vehicle owner.**
- Compass Rallye models.** Fascia trimming is required for hitch installation. Obtain vehicle owners approval before cutting.. Mark fascia with non-permanent marker Use Template as supplied in Appendix "A". See Figure 3 & 4 for fascia trimming diagrams
- 2011 and later Jeep Patriot and Compass models.** Fascia trimming is required for hitch installation. Obtain vehicle owners approval before cutting. 2011 model requires a 3 1/2" (89mm)x 6" (152mm) vertical notch (measured from the bottom of the fascia lip). Mark fascia with non-permanent marker. Confirm fascia cut height by using figure 4 procedure and mark height from ground on fascia. Cut the lower of the two marks. Use Template as supplied in Appendix "A". See Figure 5 for additional fascia trimming diagrams and dimensions

Note 2

2011 **Compass/Patriot & Rallye Package**
 It is necessary to trim bumper fascia. **Obtain vehicle owners approval** for cutting plastic fascia before installing hitch!
 fascia before installing hitch!
 See diagram (Fig. 3 or Fig 5 as appropriate).

Figure 3

Patriot Rallye Model

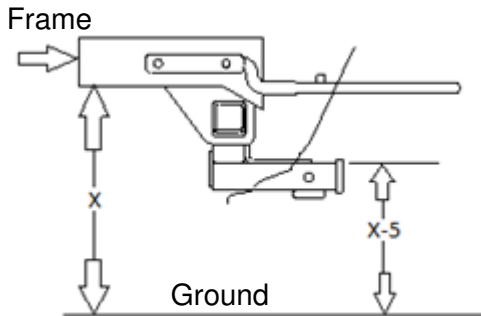
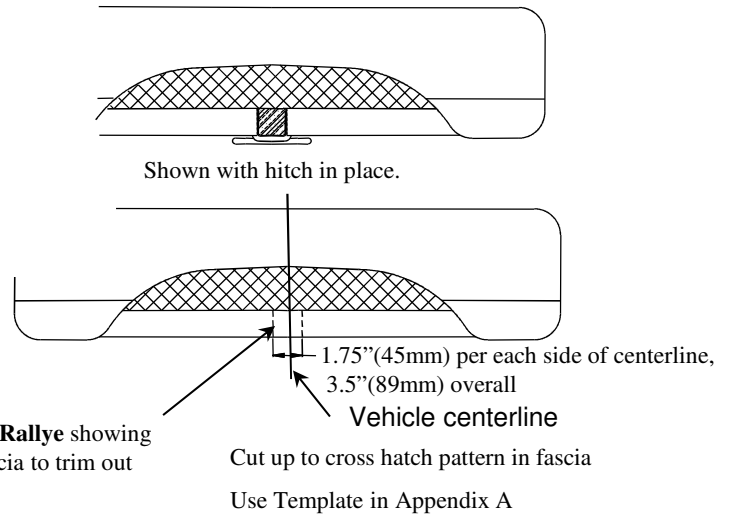

Figure 4

** X (from ground to bottom of frame) must be measured to double check placement of cut. X-5 inches is the distance measured from the ground to the top of the fascia cut.

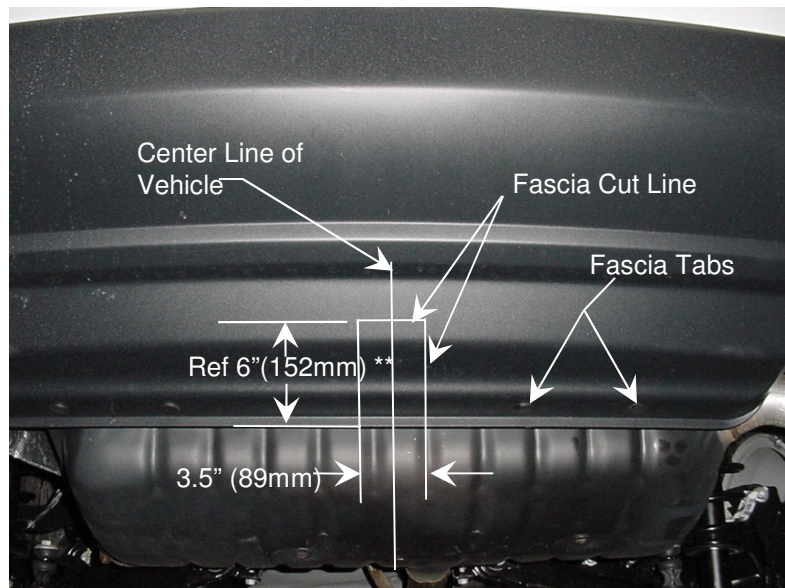

Figure 5 Fascia Trimming Diagram for 2011 & Later Jeep Patriot and Compass Models
 Use Template in Appendix A. Install hitch for final trimming

Note: check hitch frequently, making sure all fasteners and ball are properly tightened. If hitch is removed, plug all holes in trunk pan or other body panels to prevent entry of water and exhaust fumes. A hitch or ball which has been damaged should be removed and replaced. Observe safety precautions when working beneath a vehicle and wear eye protection. Do not cut access or attachment holes with a torch.

This product complies with safety specifications and requirements for connecting devices and towing systems of the state of New York, V.E.S.C. Regulation V-5 and SAE J684.

Appendix A

CHECK SCALE BEFORE USING TEMPLATE
INCHES



Template Cutout – All Models

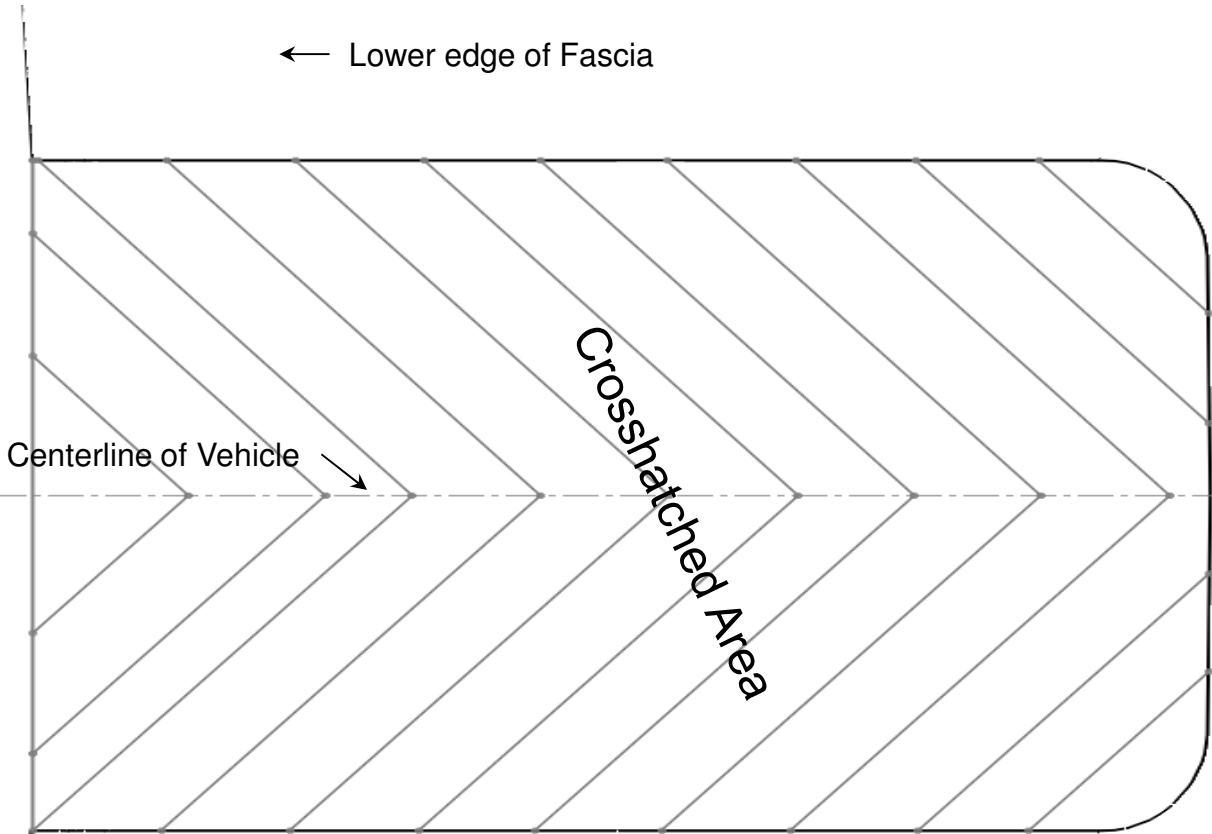

TEMPLATE INSTRUCTIONS

- 1) CHECK PRINT SCALE TO VERIFY TEMPLATE IS PRINTED TO PROPER DIMENSIONS
- 2) REMOVE CROSSHATCHED AREAS FROM TEMPLATE
- 3) ALIGN TEMPLATE WITH THE LOWER EDGE OF FASCIA AND CENTERLINE OF VEHICLE. TAPE TEMPLATE TO FASCIA
- 4) REMOVE TEMPLATE FROM FASCIA
- 5) TRIM OUT THE OPENING
- 6) ADJUST CUT AS REQUIRED FOR HITCH CLEARANCE
- 7) SMOOTH THE EDGES
- 8) RE-INSTALL FASCIA PASTENERS (IF REMOVED)

← Lower edge of Fascia

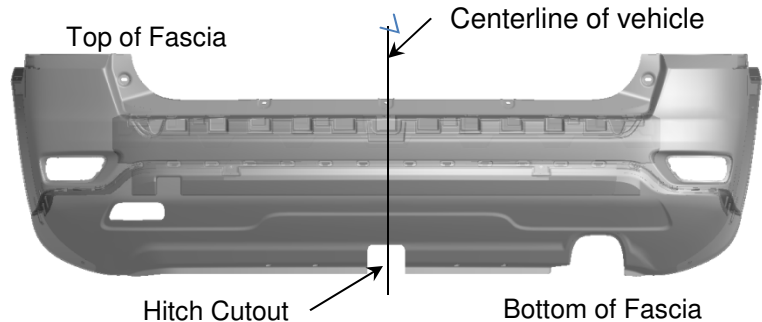

Rear View of Bumper Fascia