



Ram 3500

1

Gooseneck Prep Kit

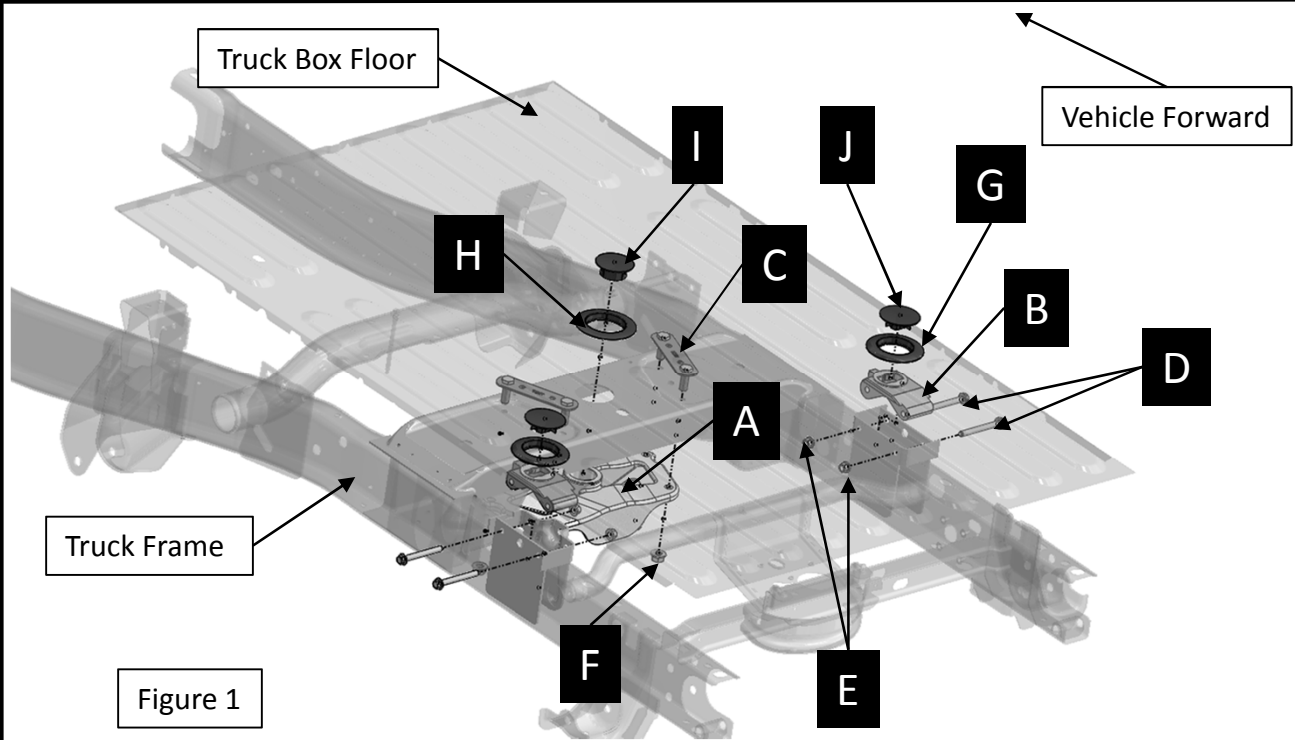
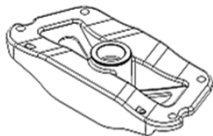

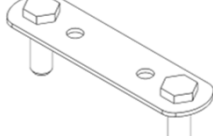









Figure 1

<p>Gooseneck receiver</p>  <p>A 1x</p>	<p>Chain tiedown receiver</p>  <p>B 2x</p>	<p>Gooseneck mounting strap</p>  <p>C 2x</p>	<p>Bolt M12-1.5x110mm</p>  <p>D 4x</p>
<p>Flange Nut M12-1.5</p>  <p>E 4x</p>	<p>Flange Nut M16-1.5</p>  <p>F 4x</p>	<p>Trim Ring – Chain Tiedown</p>  <p>G 2x</p>	<p>Trim Ring – Gooseneck Ball</p>  <p>H 1x</p>
<p>Trim Cover – Gooseneck Ball</p>  <p>I 1x</p>	<p>Trim Cover – Chain Tiedown</p>  <p>J 2x</p>		

Tools Required

Safety Eyewear



Torque wrench

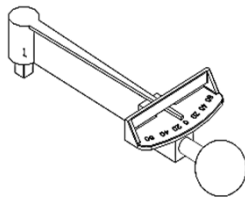

18mm, 24mm sockets
6" Ratchet extension, Ratchet

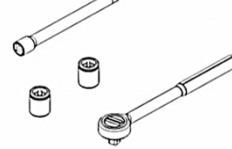

18mm, 24mm wrench



Drill motor

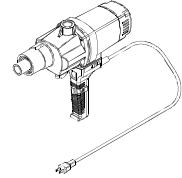

3 3/4" & 4" hole saw

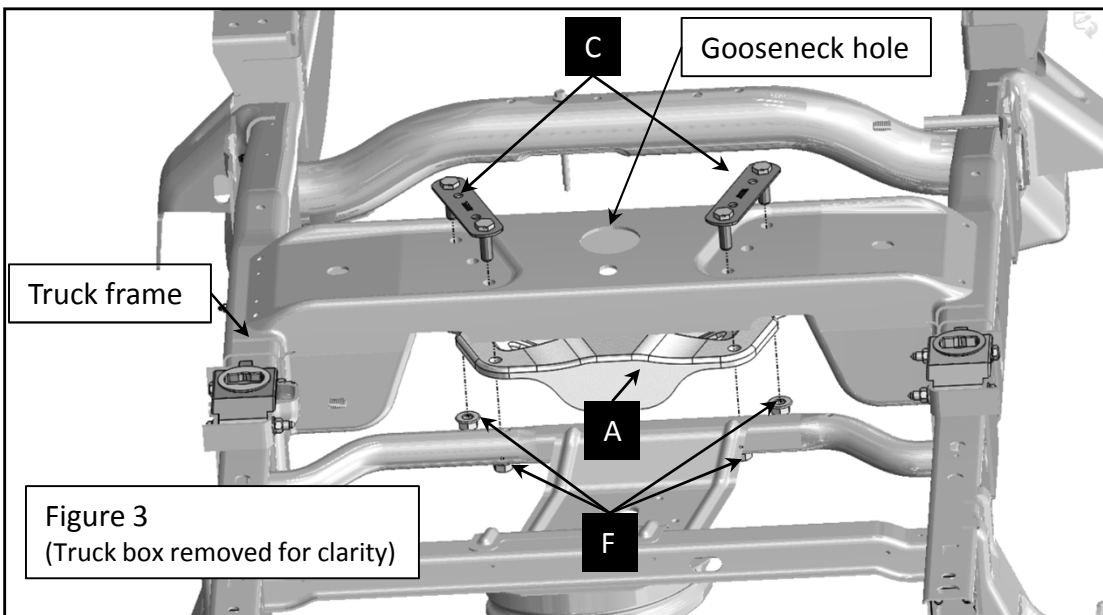
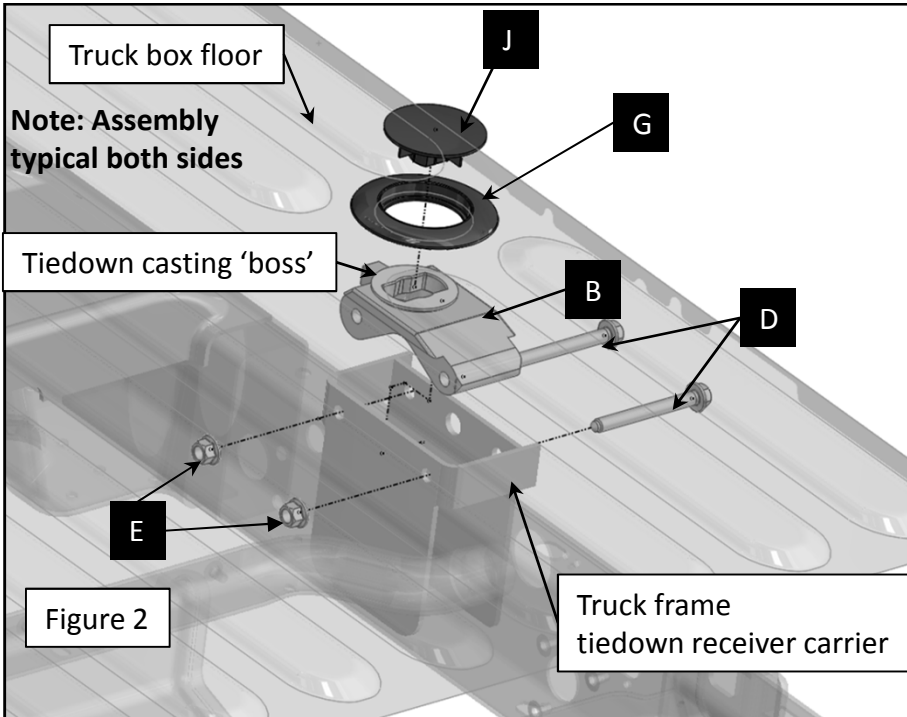

Note: check hitch frequently, making sure all fasteners and ball are properly tightened. A hitch or ball which has been damaged should be removed and replaced. Observe safety precautions when working beneath a vehicle and wear eye protection. Do not cut access or attachment holes with a torch.

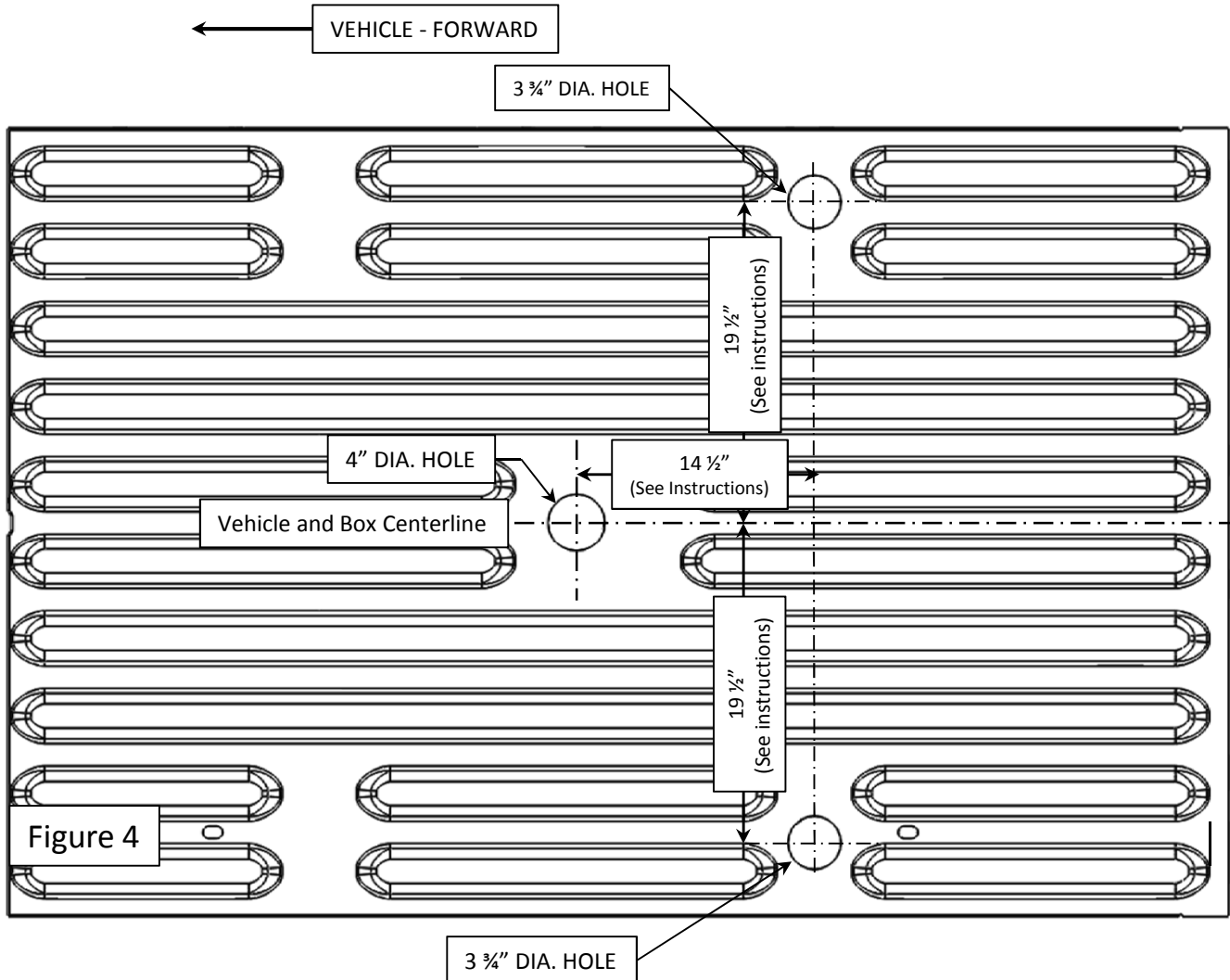

Installation Instructions

Chain tiedown receiver installation

- 1) Review and familiarize yourself with all components (Fig. 1). Verify all components are supplied
- 2) Safely block vehicle and work in a safe manner
- 3) Remove spare tire
- 4) From underneath the vehicle, locate the center of the gooseneck receiver hole. You should have a direct view of the underside of the box. Mark and drill a $\frac{1}{4}$ " pilot hole. (Fig.3)
- 5) Remove rear and mid-location (6 bolts on the 6"4" box, 8 bolts on the 8 ft box) bolts holding truck box to vehicle frame. Loosen but leave in place the two front bolts. This is done to maintain box alignment. Lift and block rear of truck box approx. 6". Check to assure no wires, fuel filler or other items attached to the box are stressed. Check also to assure there is clearance between the front of the box and rear of the cab. Finally check for clearance between the rear of the truck box and rear bumper.
- 6) Install part 'B' chain tiedown receiver in frame receiver (both sides) as shown in (Fig. 2), **NOTE ORIENTATION**.
- 7) Fasten casting (both sides) through the frame tiedown receiver carrier using 2 M12-1.5x110mm bolts and 2 M12-1.5 nuts (parts 'D' & 'E'). (Fig. 2)
- 8) At this step, both chain tiedown receivers should be in place with fasteners loosely installed
- 9) Torque bolts holding the tiedown receiver to 90 Lb.-Ft. (125 N*m)

Note: check hitch frequently, making sure all fasteners and ball are properly tightened. A hitch or ball which has been damaged should be removed and replaced. Observe safety precautions when working beneath a vehicle and wear eye protection. Do not cut access or attachment holes with a torch.

Drill Holes in truck box floor

When installing the 822136664AB Gooseneck prep kit, 3 holes must be drilled in the bed of the truck. It is critical that these directions are followed.

- 10) From inside the box, mark the centerline of the box using the ¼" hole drilled in step 4 as a guide. Use chalk or some other temporary marking method. Measure and mark a spot 14 ½" (368mm) rearward of the ¼" hole. Strike an additional line 90° (degrees) to the spot marked.
- 11) Measure outward in both directions, along the line you marked in the previous step, 19 ½" (495mm). You should have two targets marked (See Figure 4)
- 12) Drill ¼" pilot hole two (rh & lh) places where you marked. **CHECK YOUR WORK!** From the top of the bed, verify that the ¼" holes match the dimensions and appearance of Fig. 4. **THIS IS YOUR LAST CHANCE** to make adjustments before drilling the large 3 ¾" & 4" holes in your truck bed.
- 13) Chain tiedown receiver - Drill 3 ¾" holes in the two places for where you drilled the two ¼" pilot holes in the previous step.
- 14) Gooseneck receiver - Drill a 4" hole using a hole saw. Use the ¼" pilot hole drilled in "Chain tiedown receiver installation" step 4 (Fig. 4)
- 15) Use rust inhibitor or equivalent primer paint on raw edges of drilled holes. Paint as desired to match truck color.

Gooseneck receiver installation

- 16) Install 2 gooseneck mounting straps (part 'C') through the two diagonal holes in vehicle frame cross member. (See Fig. 3).
- 17) From beneath vehicle frame, insert gooseneck ball receiver casting through the 4 bolts from part 'C' gooseneck mounting straps.
- 18) Install 4 M16-1.5 nuts (part 'F') on threaded bolts. Torque nuts to 225 Lb.-Ft. (305 N*m)
- 19) Lower rear of truck bed back on frame of vehicle

CHECK YOUR WORK! From the top of the bed, verify that the holes in the bed align with the gooseneck ball receiver and chain tiedown receivers. Some slight adjustment of the truck box is possible. If there is a slight misalignment, install the appropriate trim ring and mark the outside perimeter of the ring on the truck box floor. Remove the trim ring. It is permissible to grind the opening if needed to within 1/8" of the marked outside trim ring perimeter.

21. Torque truck bed hold down bolts to specification (See RAM service manual for torque specs.)
22. Reinstall spare tire, Verify that all wires, fuel fill and any other box to frame components have not been pinched or otherwise disturbed.

Step D Trim rings and covers installation

- 23) Trim rings– Press trim rings (items G & H) into holes in floor. Trim rings should snugly fit around castings with the lip of the trim ring tight to the floor. It may be necessary to use a flat bladed tool to assist in fitting trim rings around the castings. Use a plastic trim tool or similar item. Use of a sharp tool or flat blade screwdriver may damage the trim ring. NOTE: Trim rings are not the same. there are 2 rings for the chain tiedowns and 1 ring for the gooseneck receiver.
- 24) Trim covers - Press trim covers (parts I & J) into trim ring holes in floor. Trim covers should snugly fit inside the trim rings. NOTE: Trim covers are not the same. there are 2 covers for the chain tiedowns and 1 cover for the gooseneck receiver.

Tighten all (4) M12 bolts with torque wrench to 90 Lb.-Ft. (125 N*m)

Tighten all (4) M16 bolts with torque wrench to 225 Lb.-Ft. (305 N*m)

Note: check hitch frequently, making sure all fasteners and ball are properly tightened. A hitch or ball which has been damaged should be removed and replaced. Observe safety precautions when working beneath a vehicle and wear eye protection. Do not cut access or attachment holes with a torch.