

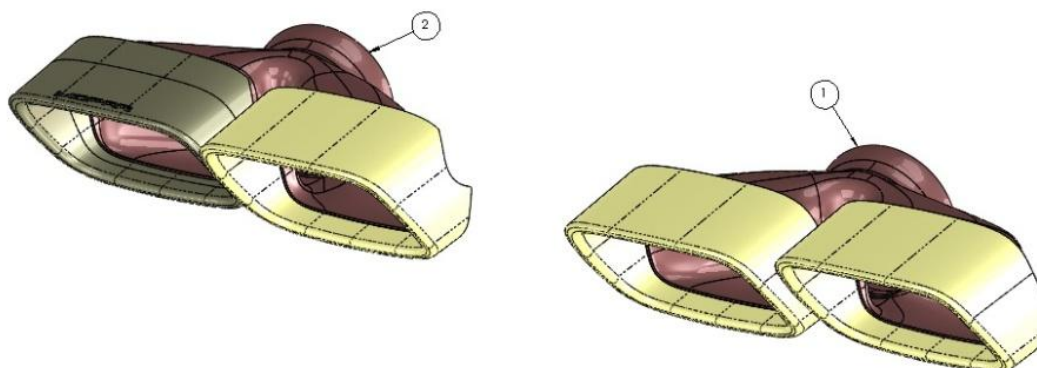

# Challenger Exhaust Tip

www.mopar.com



## Parts list:

- (1) R/H (passenger side) tip
- (2) L/H (driver side) tip

## REMOVAL:

**CAUTION:** Let exhaust cool before working on tips to avoid injury.

- The tailpipe on the vehicle does not need to be cut in order to install the tip.
- Remove original tips by loosening the 13mm bolt located on the clamp between the tip and the muffler on both sides of the vehicle and pulling the original tip rearward, reference figure 1.

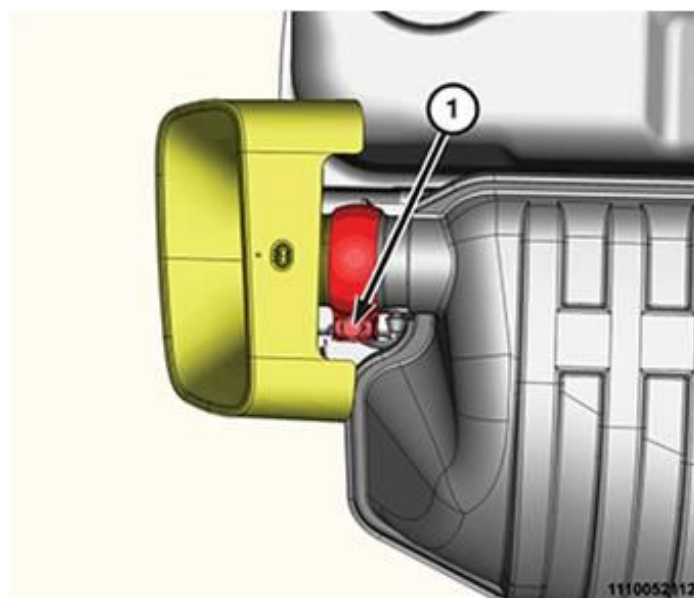

Figure 1 (Driver's side shown)

**INSTALLATION:**

- Position the clamps with the bolts to the side as seen in Figure 2. Slide the tip over the pipe and under the clamp and snug the clamp.
- Position the tips in the center of their rear fascia openings and torque the bolts to 24 ft-lbs. See Fig. 3.



Figure 2 (Passenger's side)

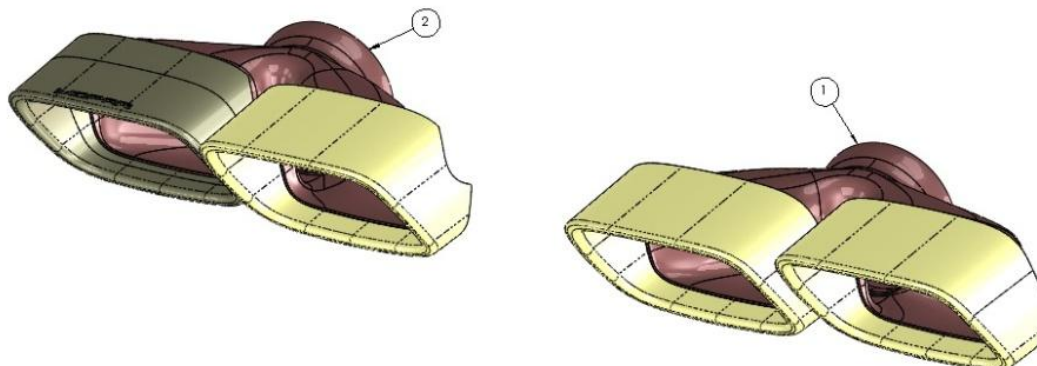

Figure 3



# Embout d'échappement Challenger

www.mopar.com



## Liste des pièces :

- (1) Embout droit (côté passager)
- (2) Embout gauche (côté conducteur)

## RETRAIT :

**ATTENTION :** Laissez l'échappement refroidir avant de travailler sur l'embout pour éviter les blessures.

- La tubulure arrière d'échappement sur le véhicule n'a pas besoin d'être coupée pour installer l'embout.
- Retirez les embouts d'origine en desserrant le boulon de 13 mm situé sur la bride entre l'embout et le silencieux des deux côtés du véhicule et en tirant vers soi l'embout d'origine (Figure 1).

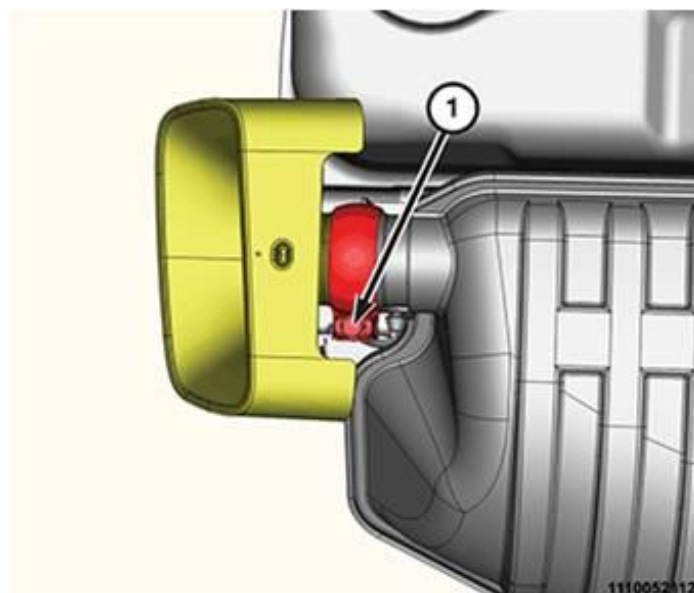

Figure 1 (Côté du passage illustré)

**INSTALLATION :**

- Positionnez les brides avec les boulons sur le côté, comme illustré à la Figure 2. Faites glisser l'embout sur le tuyau et sous la bride et serrez la bride.
- Positionnez les embouts sur le centre des ouvertures de la bordure arrière et serrez les boulons au couple à 24 pi-lb. Voir la Figure 3.



Figure 2 (Côté passager)

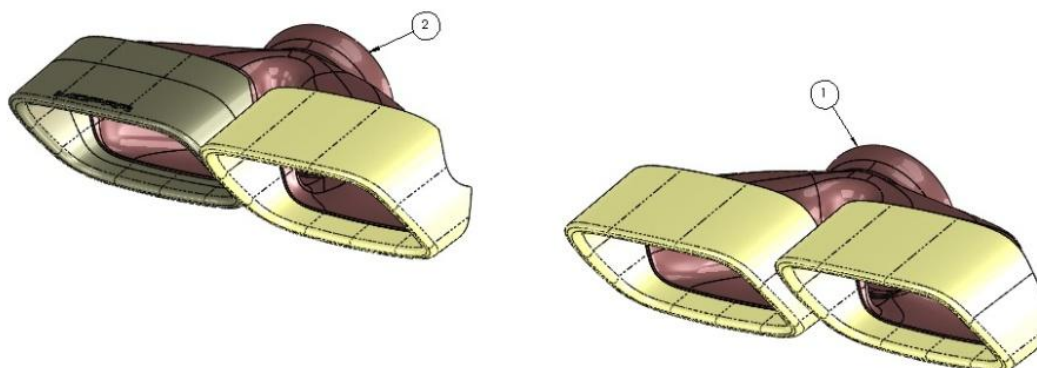

Figure 3



# Challenger Exhaust Tip

www.mopar.com



## Lista de Piezas:

- (1) Boquilla lado derecho (lado del acompañante)
- (2) Boquilla lado izquierdo (lado del conductor)

## EXTRACCIÓN:

**PRECAUCIÓN:** Deje enfriar el tubo de escape antes de trabajar sobre las boquillas para evitar lesiones.

- Para instalar la boquilla no se necesita cortar el tubo de cola.
- Extraiga las boquillas originales aflojando el perno de 13 mm que está en la abrazadera entre la boquilla y el silenciador de ambos lados del vehículo y retirando la boquilla original hacia atrás. Vea la figura 1.



Figura 1 (del lado del conductor)

**INSTALACIÓN:**

- Posicione las abrazaderas con los pernos a un lado, como se ve en la Figura 2. Deslice la boquilla sobre el caño y por debajo de la abrazadera y ajuste la abrazadera.
- Posicione las boquillas en el centro de las aberturas de la defensa trasera y ajuste los pernos en 24 pies-libras. Vea la Fig. 3

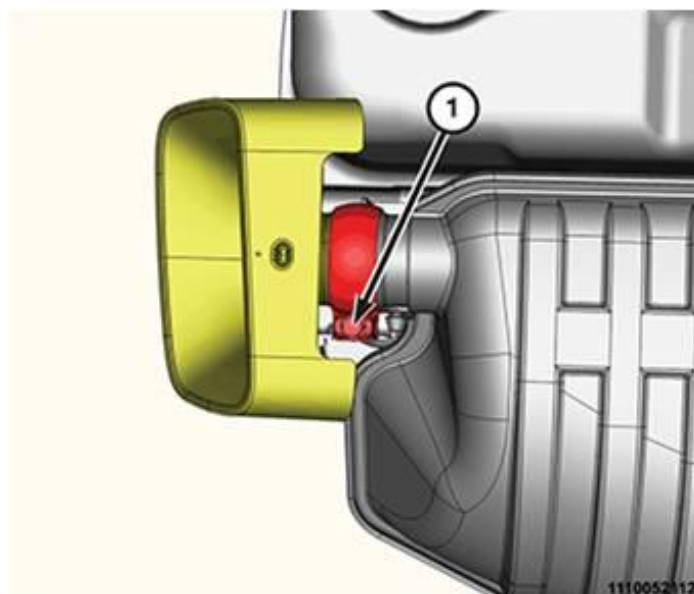

Figura 2 (del lado del acompañante)



Figura 3

# Document Revision History

Date	Section	Summary of Changes Made	Notes
10/15/15		Created	KAB