

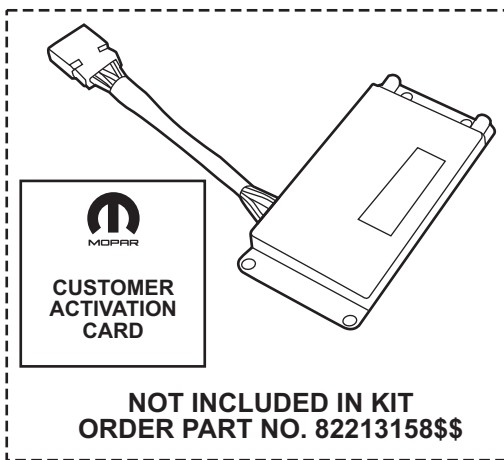

# 2014 - 2015 GRAND CHEROKEE / DURANGO MOPAR CONNECT INSTALLATION KIT

www.mopar.com

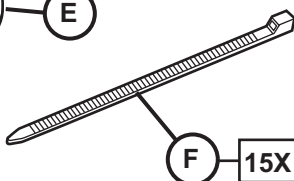
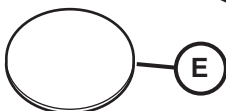
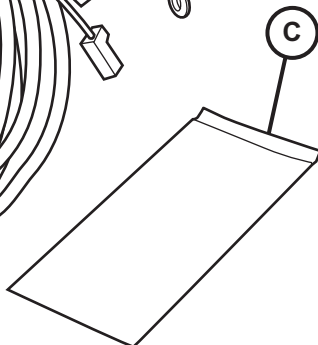
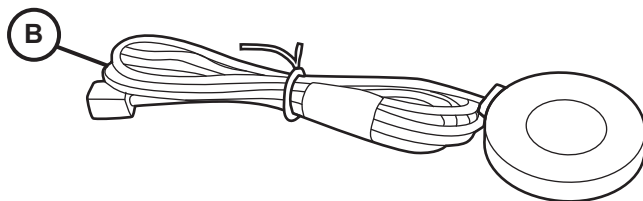
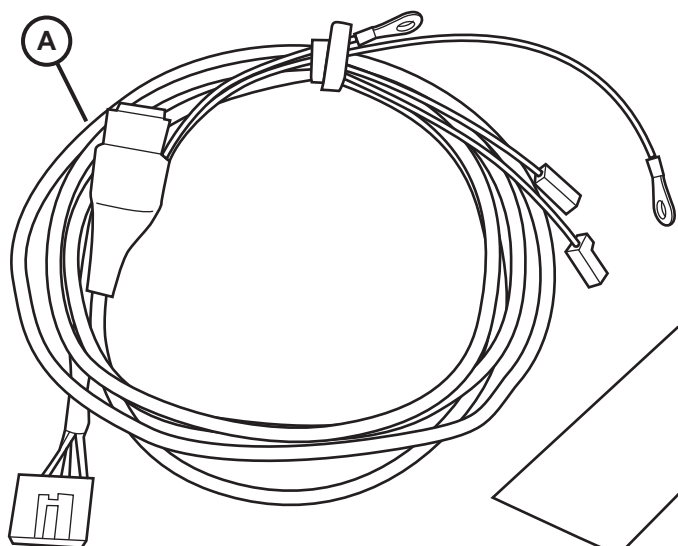

NOTE: ALCOHOL PAD WILL BE USED MORE THAN ONCE. RESEAL TO PREVENT PAD FROM DRYING OUT.

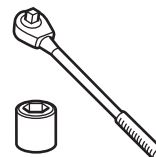
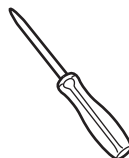
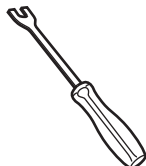

RETAIN ALL FASTENERS FOR REINSTALLATION

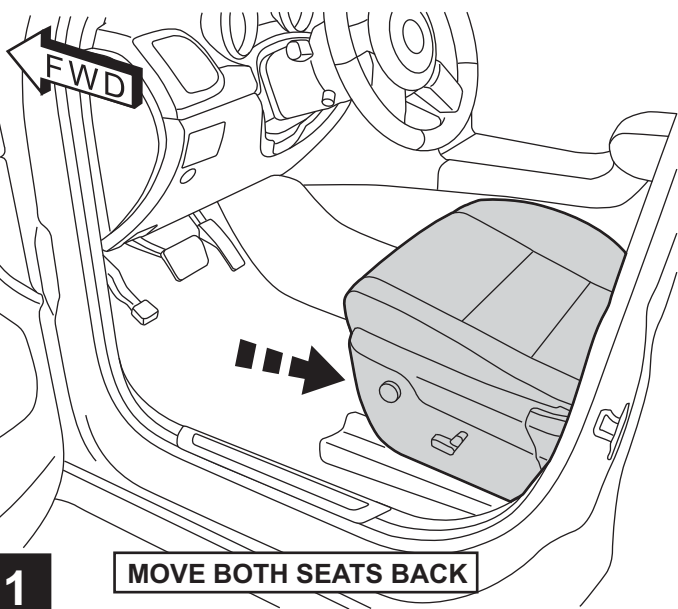
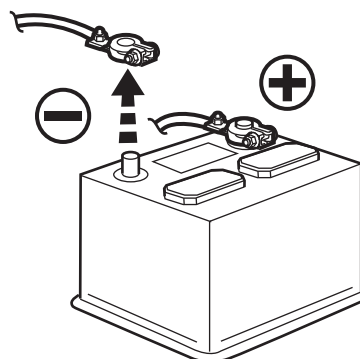

2

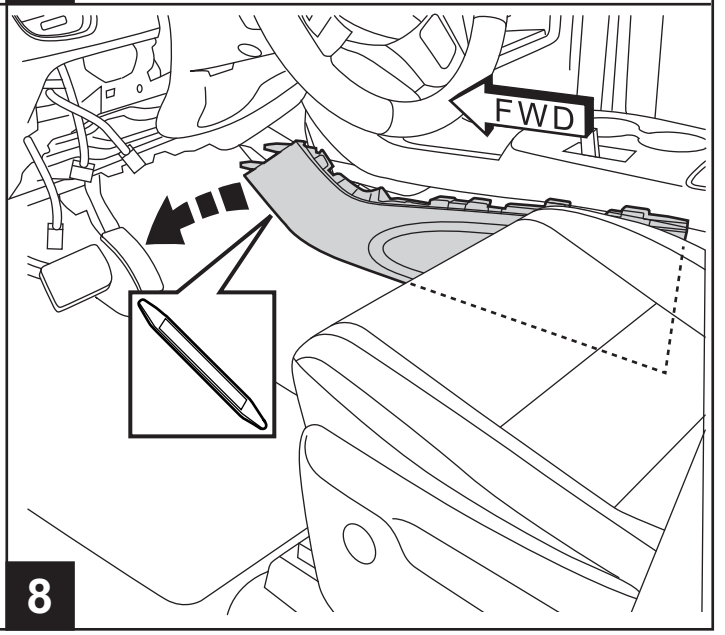
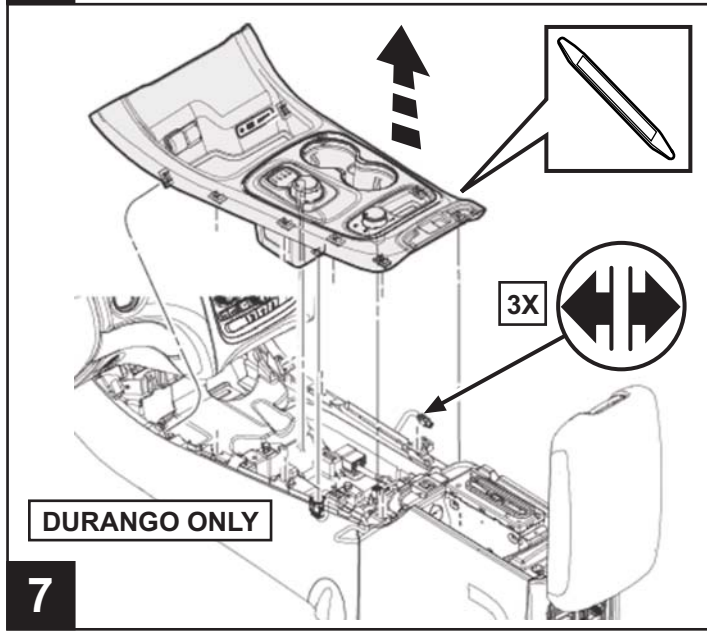
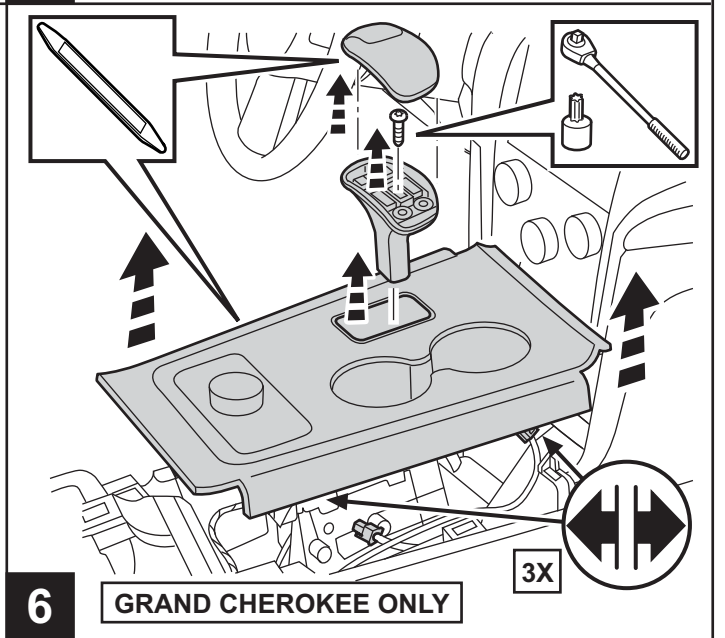
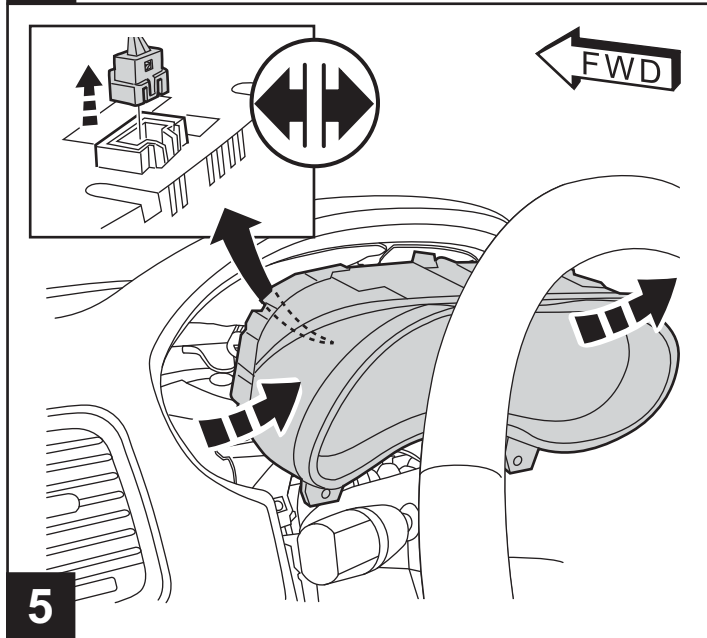
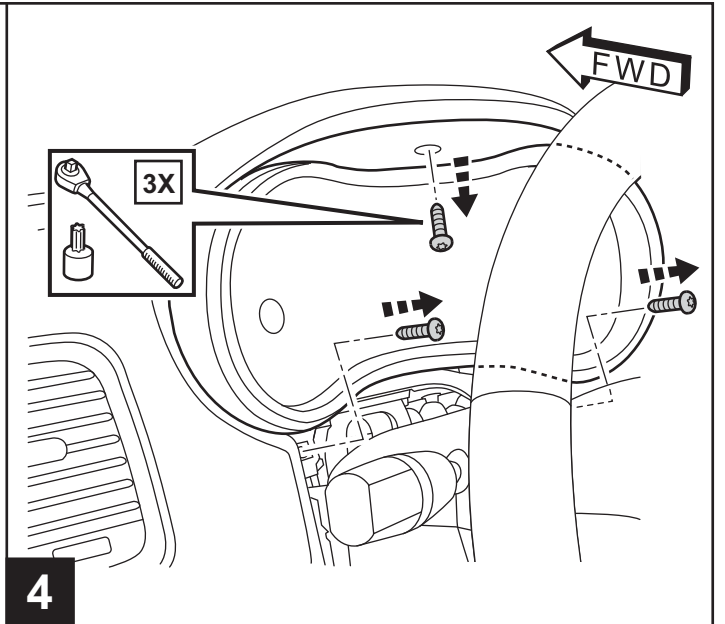
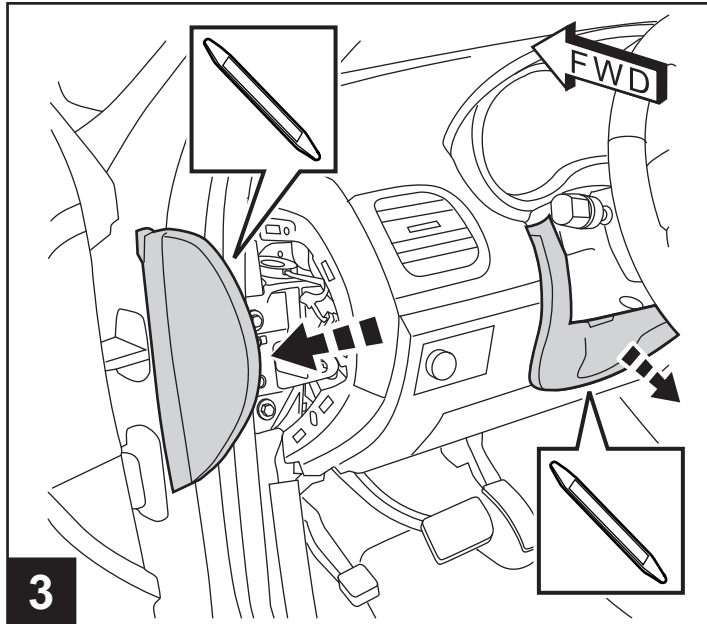

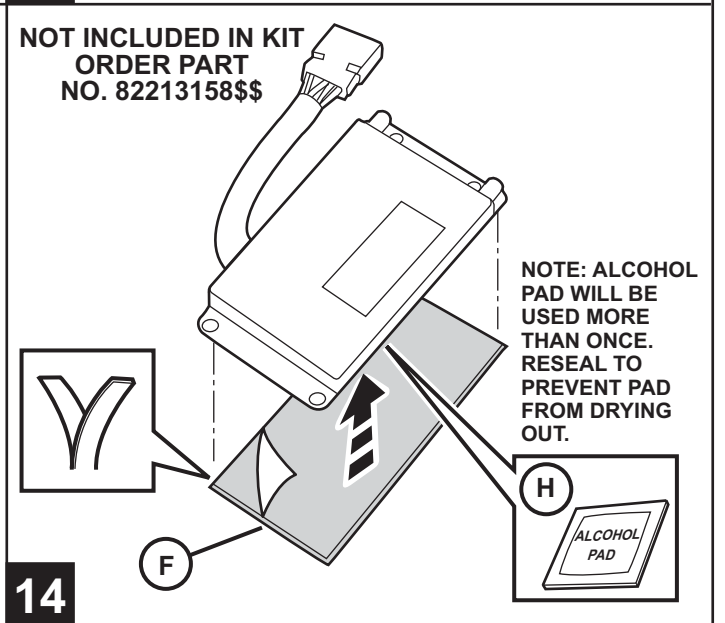
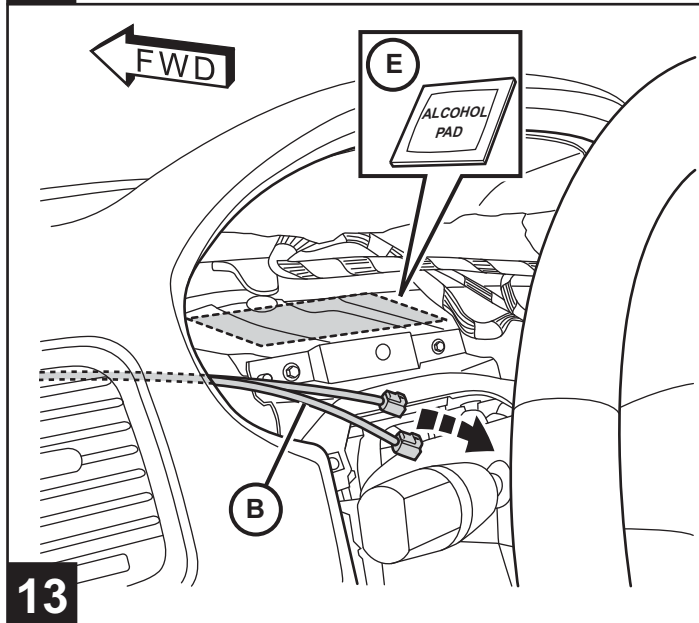
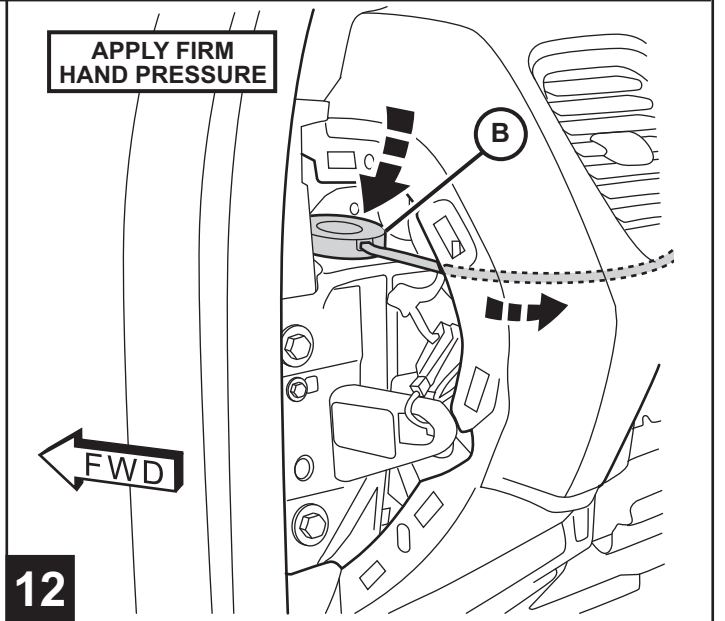
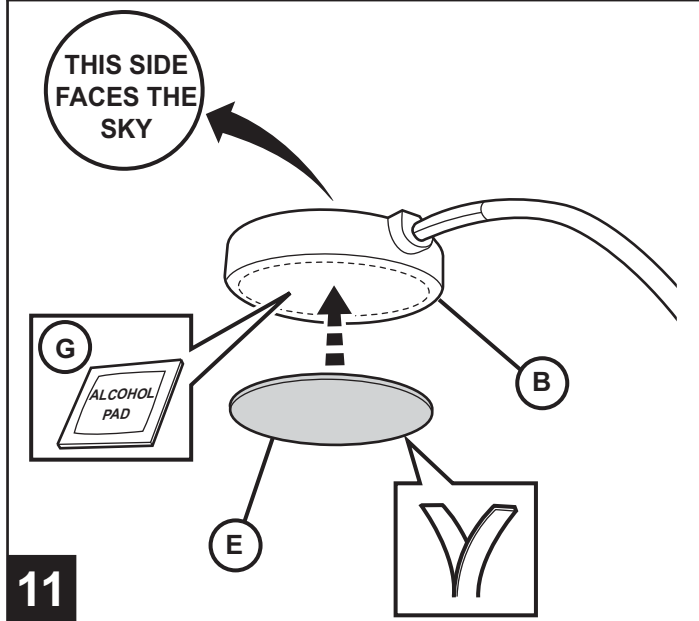
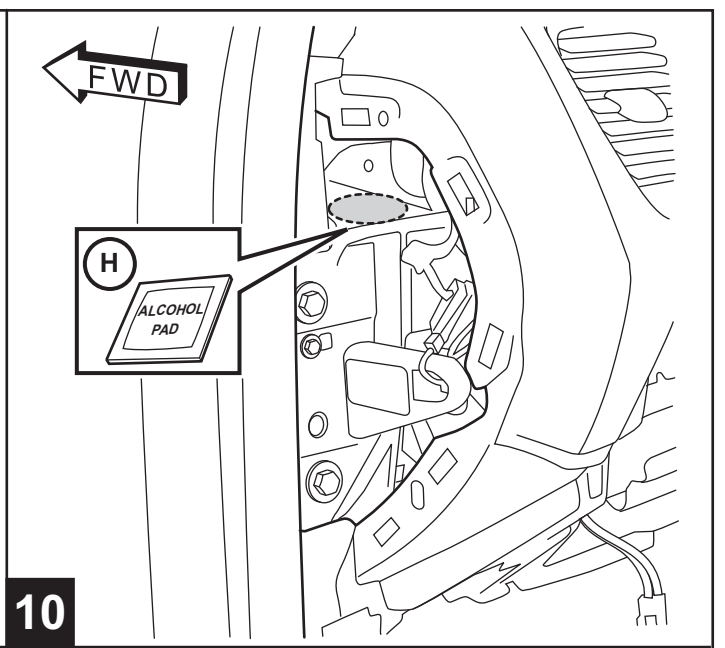
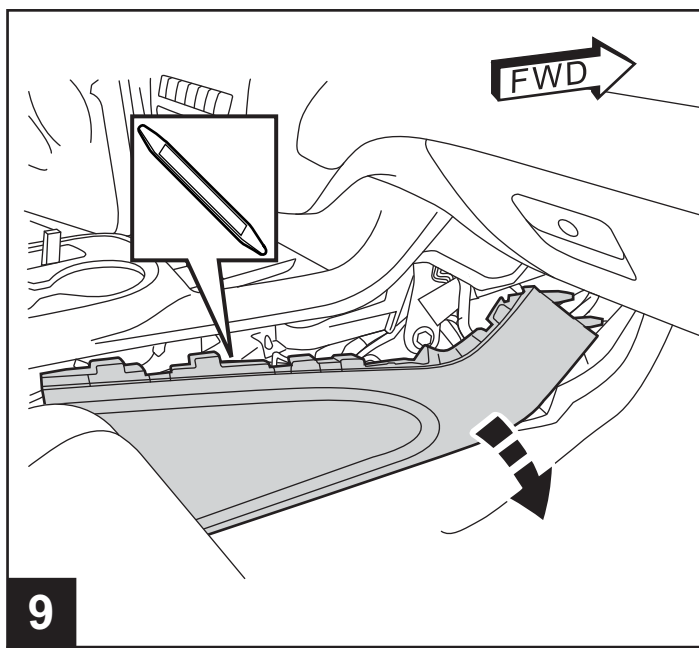

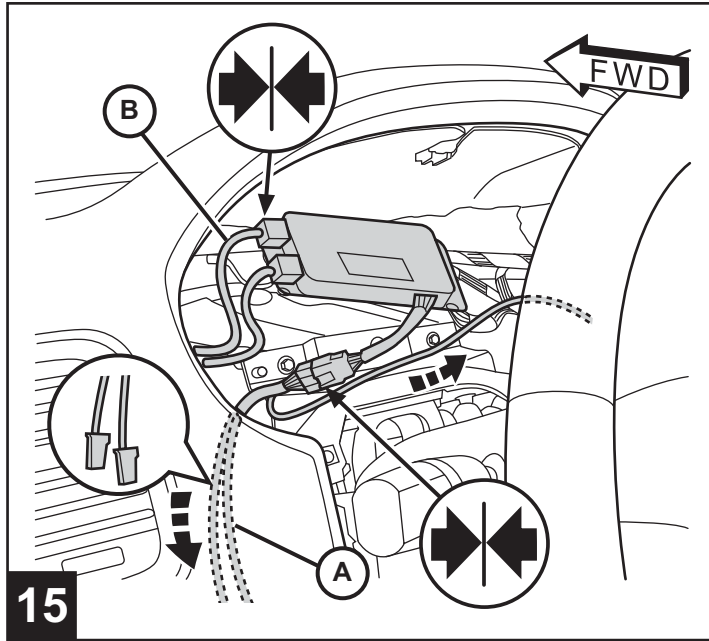

15

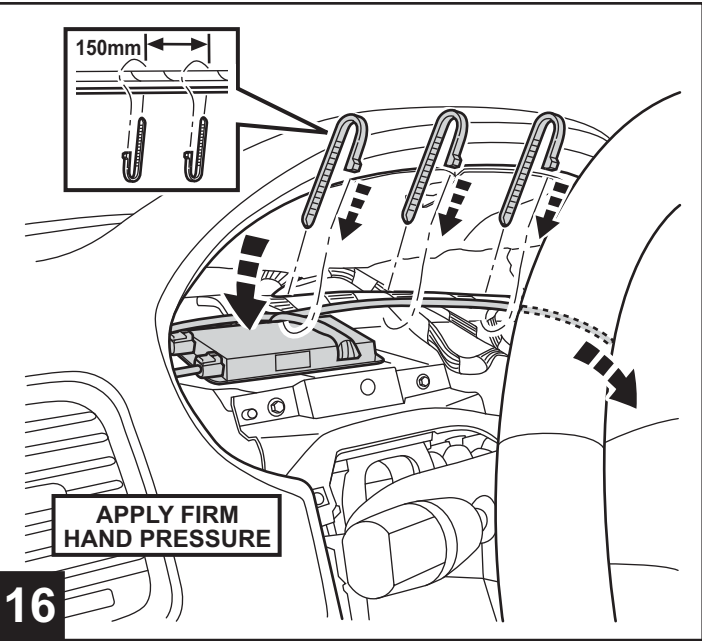

16

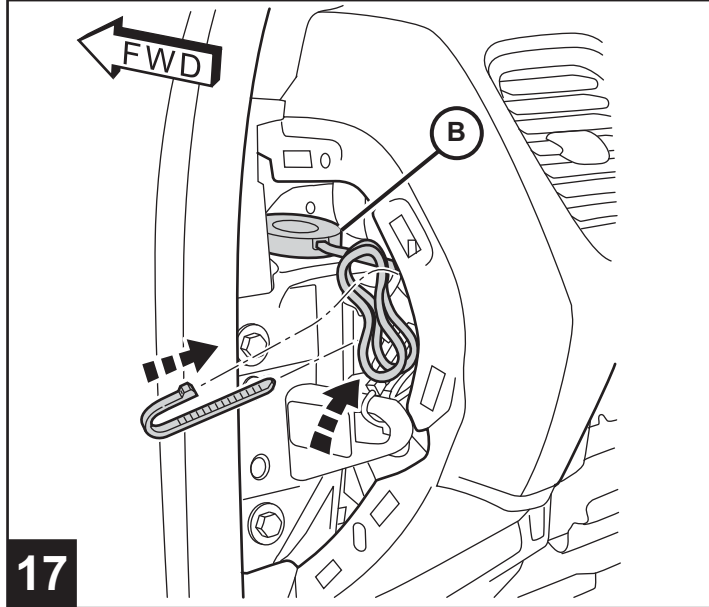

17

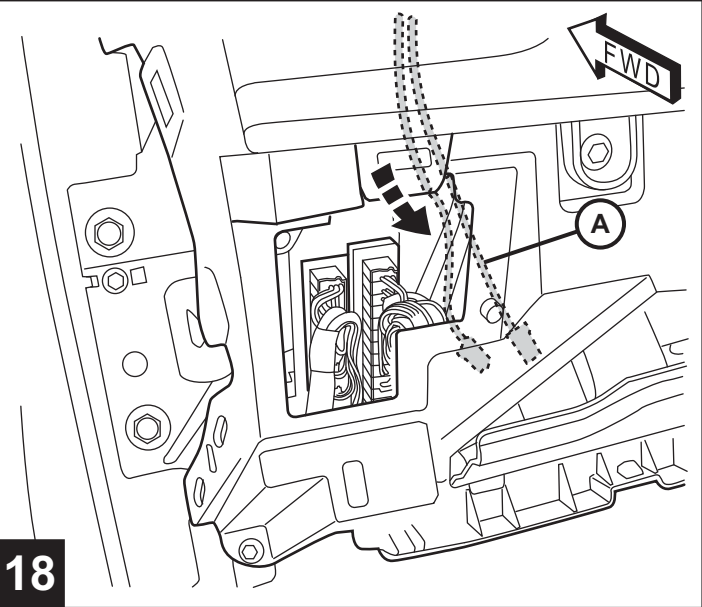

18

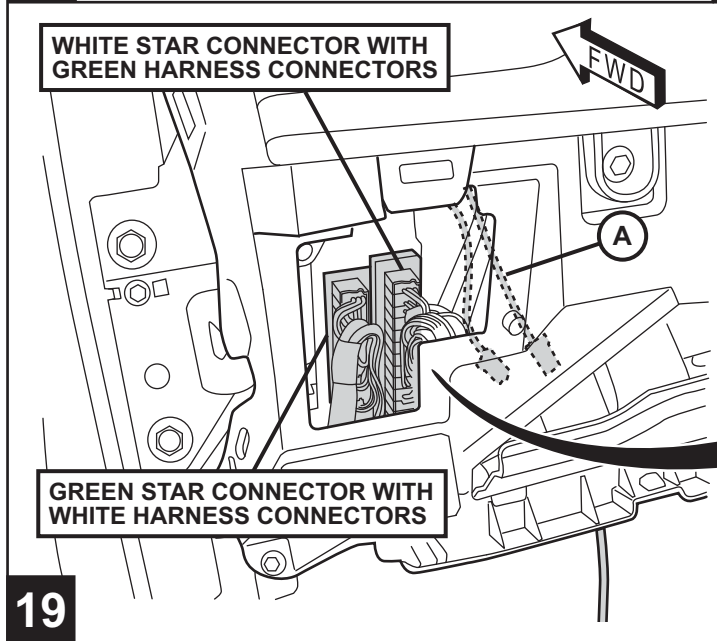

19

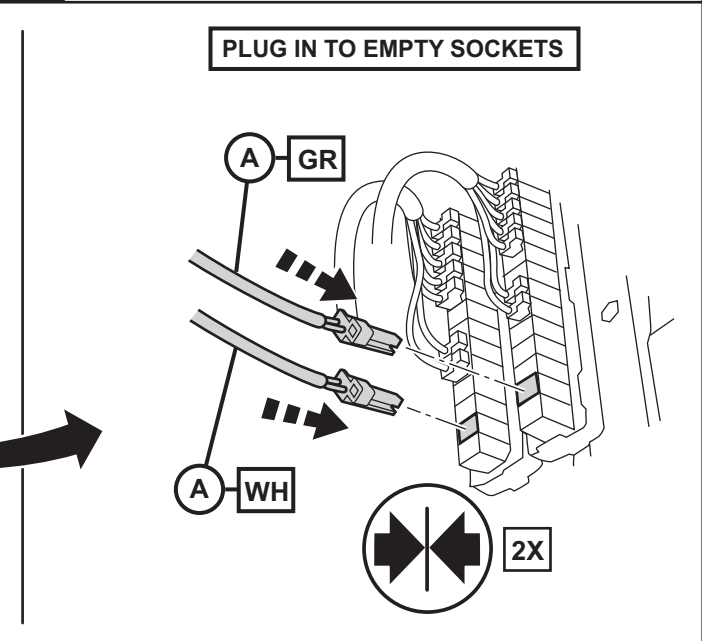

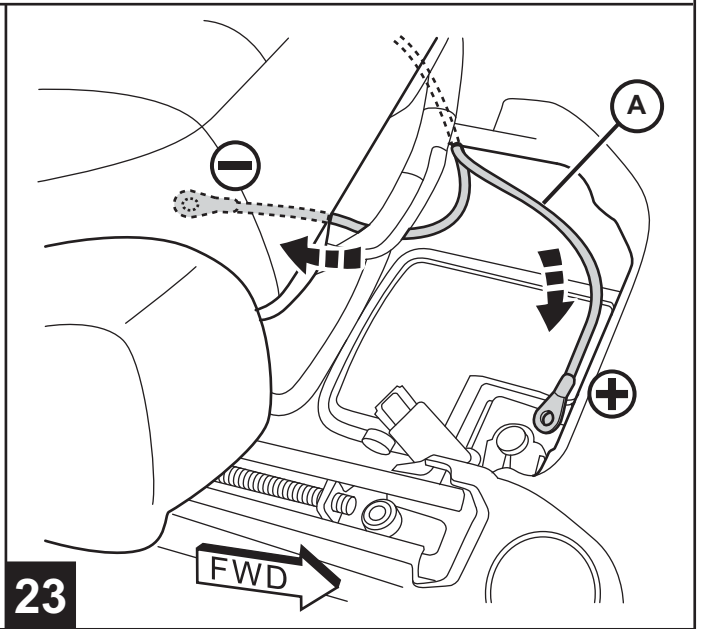
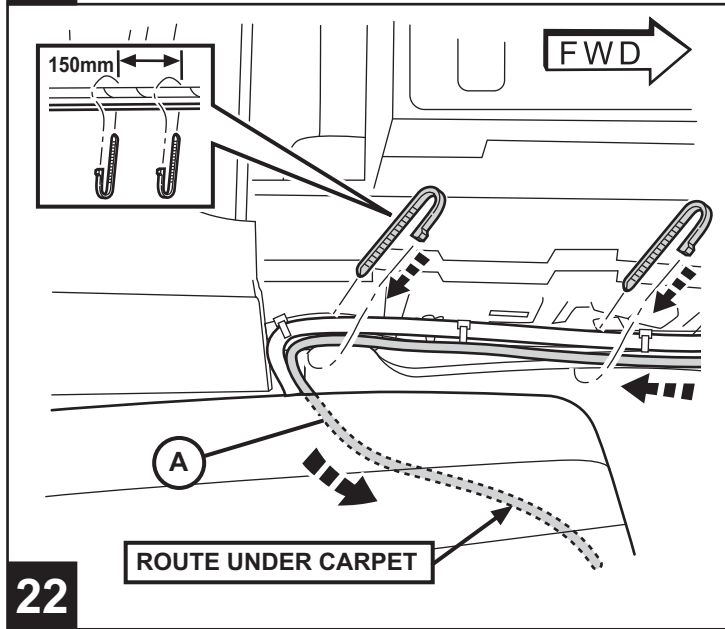
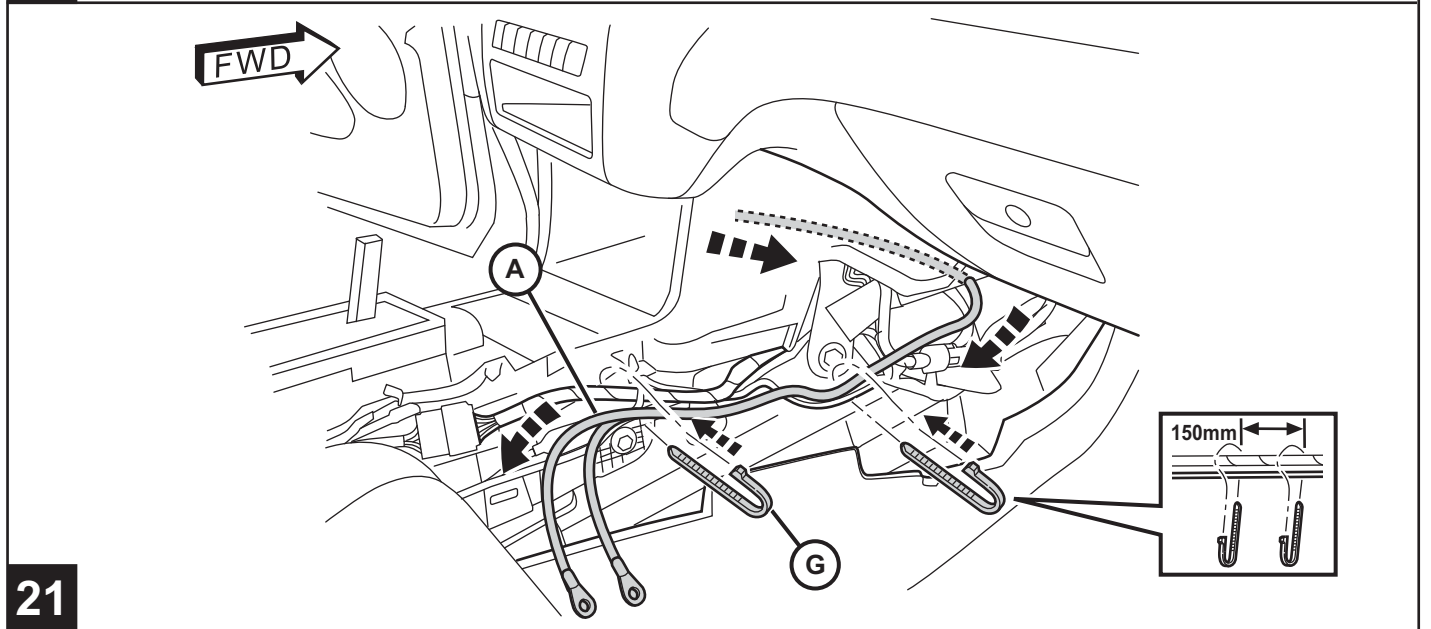
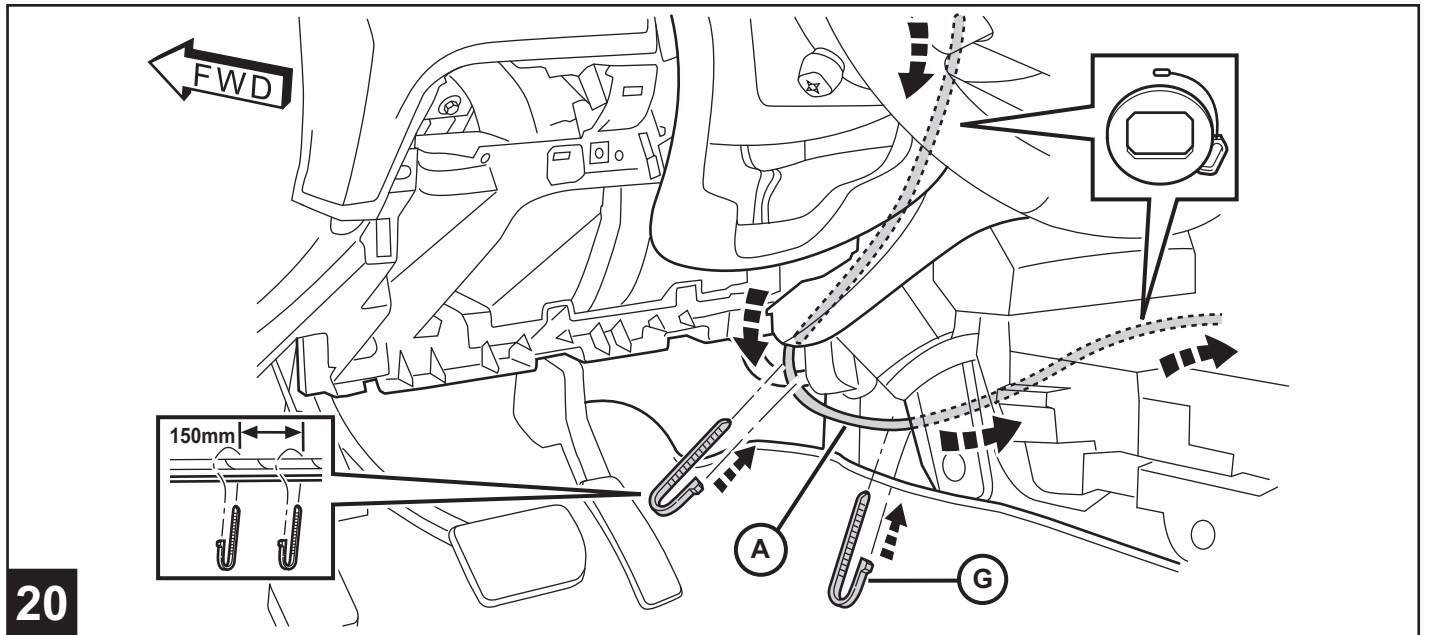

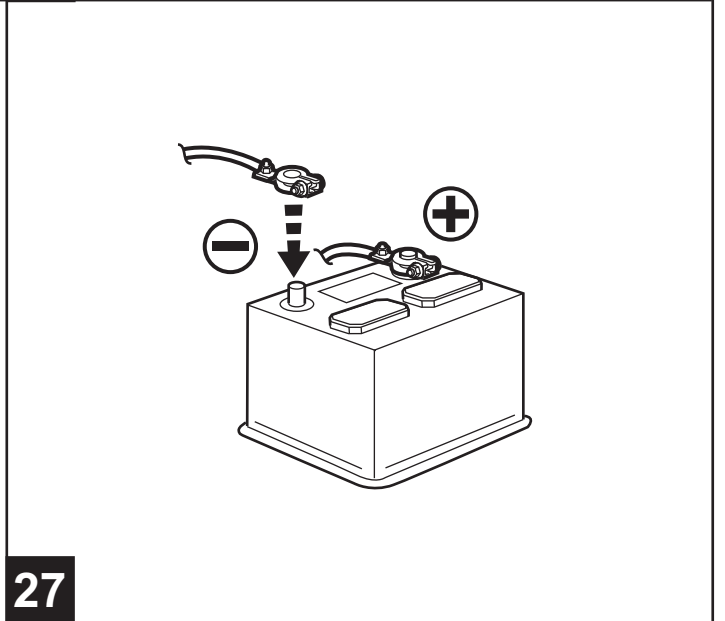
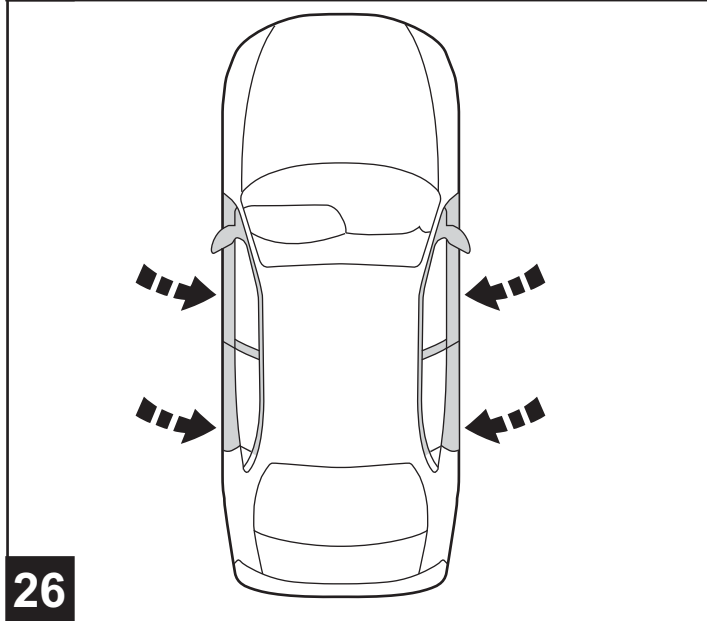
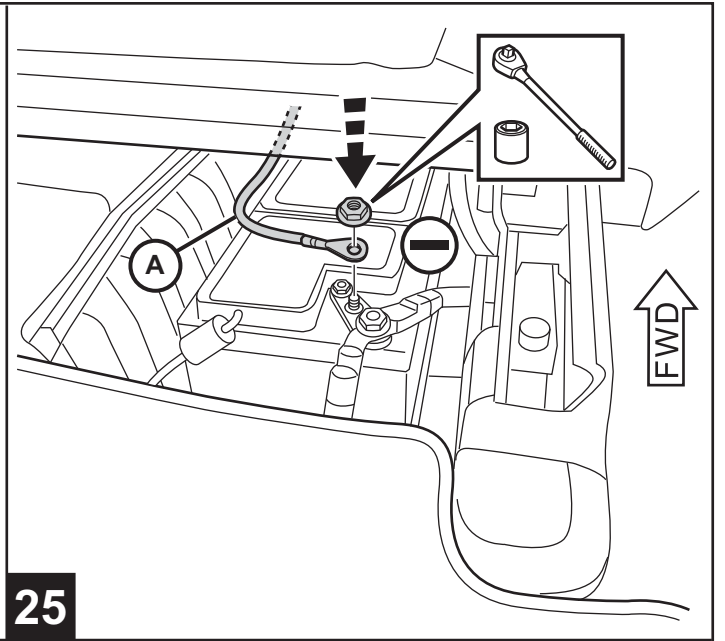
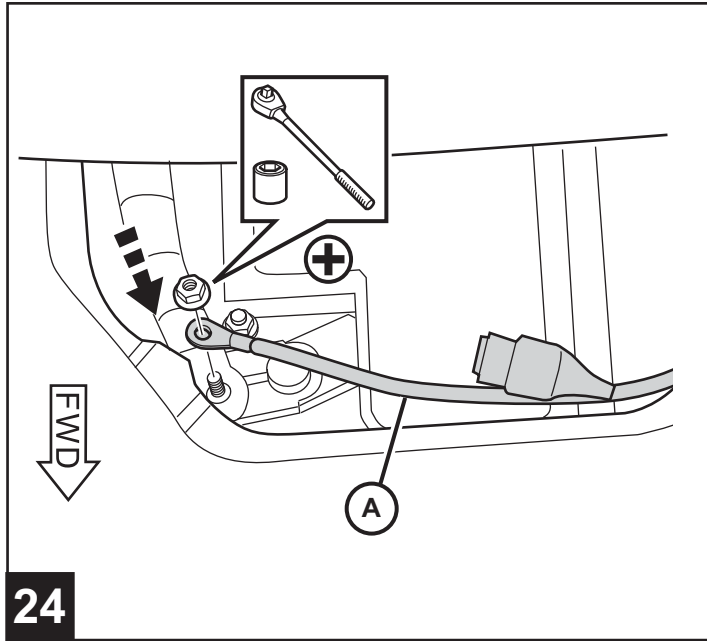

REFER TO END OF LINE (EOL) TEST PROCEDURE  
ON THE FOLLOWING PAGES

28

## Mopar Connect – End Of Line (EOL) Procedure

### To be performed by the installer

The EOL procedure will verify proper function/installation of the Mopar Connect Module and Installation Kit in the vehicle.

Equipment Needed To Perform This Procedure:

- Laptop or PC with internet access
- Smart phone

**NOTE: Some screens and commands may be different based on the smartphone operating system. For example, some smartphone operating systems require that you press “login” or “enter” to continue. If assistance is needed, please call Autonet Mobile Customer Care Center at 1-855-756-6727.**

Questions regarding this procedure should be directed to  
Autonet Mobile Customer Care Center at  
1-855-756-6727

---

### Testing the Mopar Connect Module After Installation In The Vehicle

1. Ensure that all doors have been closed on the vehicle for at least 3 minutes.  
Have all doors been closed on the vehicle for at least 3 minutes?
  - a) **No**, go to Step 2.
  - b) **Yes**, go to Step 3.
2. Close all doors and wait 3 minutes before continuing to Step 3.
3. Open driver’s door and turn ignition switch to RUN position within 15 seconds of opening the driver’s door. If this is not completed within 15 seconds, go back to Step 2, otherwise, continue to next step.
4. Leave the ignition key in the RUN position for up to 3 minutes while the Mopar Connect module reads the VIN of the vehicle and re-writes the Network Name (SSID) that will be used in the next step.
5. After 3 minutes have elapsed, open the wireless network list on the smart phone, laptop, or PC. Look for a Network Name (SSID) that either says “**mopar-XXXX**” (where XXXX are the last 4 digits as the vehicle’s VIN) or “**autonet-NNNN**” (where NNNN are the last 4 digits of the Mopar Connect Module’s serial number). The serial number can also be found on the Activation Card that will be given to the customer.
  - a) If “**autonet-NNNN**” appears in the network list, continue to step 6.
  - b) If “**mopar-XXXX**” appears in the network list, connect to that network and continue to Step 7.
6. Turn ignition key to off position. Close driver’s door. Disconnect Mopar Connect module. Wait 15 seconds. Reconnect Mopar Connect Module. Go back to Step 3 and start over.

## Mopar Connect – End Of Line (EOL) Procedure (continued)

7. Open the web browser on the device (smartphone, laptop or PC) and go to:  
<http://www.autonetrouter.com/eol>

**NOTE: Some screens and commands may be different based on the smartphone operating system. For example, some smartphone operating systems require that you press “login” or “enter” to continue. If assistance is needed, please call Autonet Mobile Customer Care Center at 1-855-756-6727.**

If the following screen appears after opening the browser on the device or the browser redirects you to this screen:



Do not press Login, rather, in the URL Address Bar of the browser, type  
<http://www.autonetrouter.com/eol>  
 and press Enter.

**NOTE: Some screens and commands may be different based on the smartphone operating system. For example, some smartphone operating systems require that you press “login” or “enter” to continue. If assistance is needed, please call Autonet Mobile Customer Care Center at 1-855-756-6727.**

If the following screen appears while trying to access the URL above, go back to Step 5 and start over, otherwise, continue to the next Step.





## Mopar Connect – End Of Line (EOL) Procedure (continued)

8. Successful access to <http://www.autonetrouter.com/eol> will display the following screen: (VIN may or may not be present)

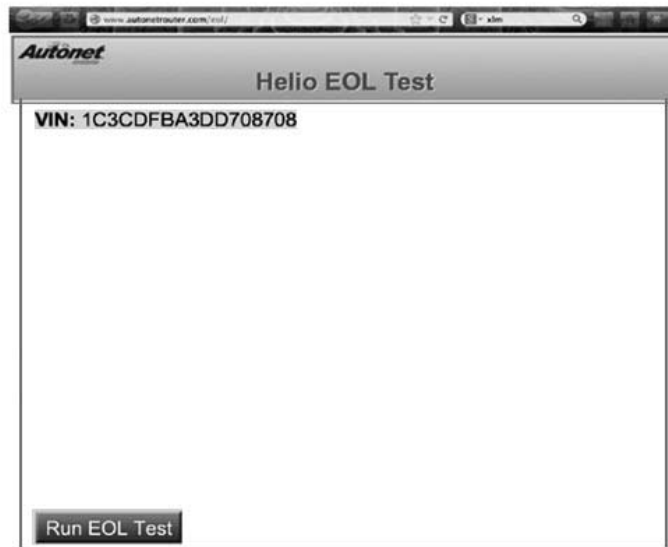

9. The EOL test consists of two parts:

- Verification of proper connection of the Mopar Connect module to the vehicle's CAN bus as indicated by the displaying of the vehicle's VIN on the browser screen.
- Verification of communication via network/WiFi as indicated by the Pass/Fail message in the center of the screen when the EOL test is executed from the browser screen.

For proper function of the Mopar Connect module, both parts (9a and 9b) of the EOL test must pass.

10. Click on the button "Run EOL test"

11. If both parts of the EOL test passes, the following will be displayed:

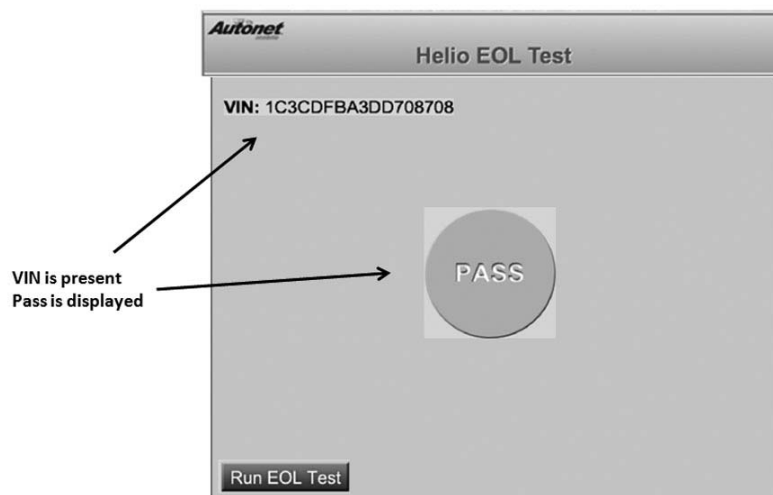

## Mopar Connect – End Of Line (EOL) Procedure (continued)

If both parts of the EOL test pass, then EOL testing is complete. Otherwise, continue to Step 12.

12. If one or both parts of the EOL test fail, any of the following screens can be displayed:

**NOTE:** It is possible to fail one part and pass the other. For example, a green color Pass indicator on the center of the browser screen, but VIN missing on the browser screen does not signify a successful pass of the EOL test. See example below.

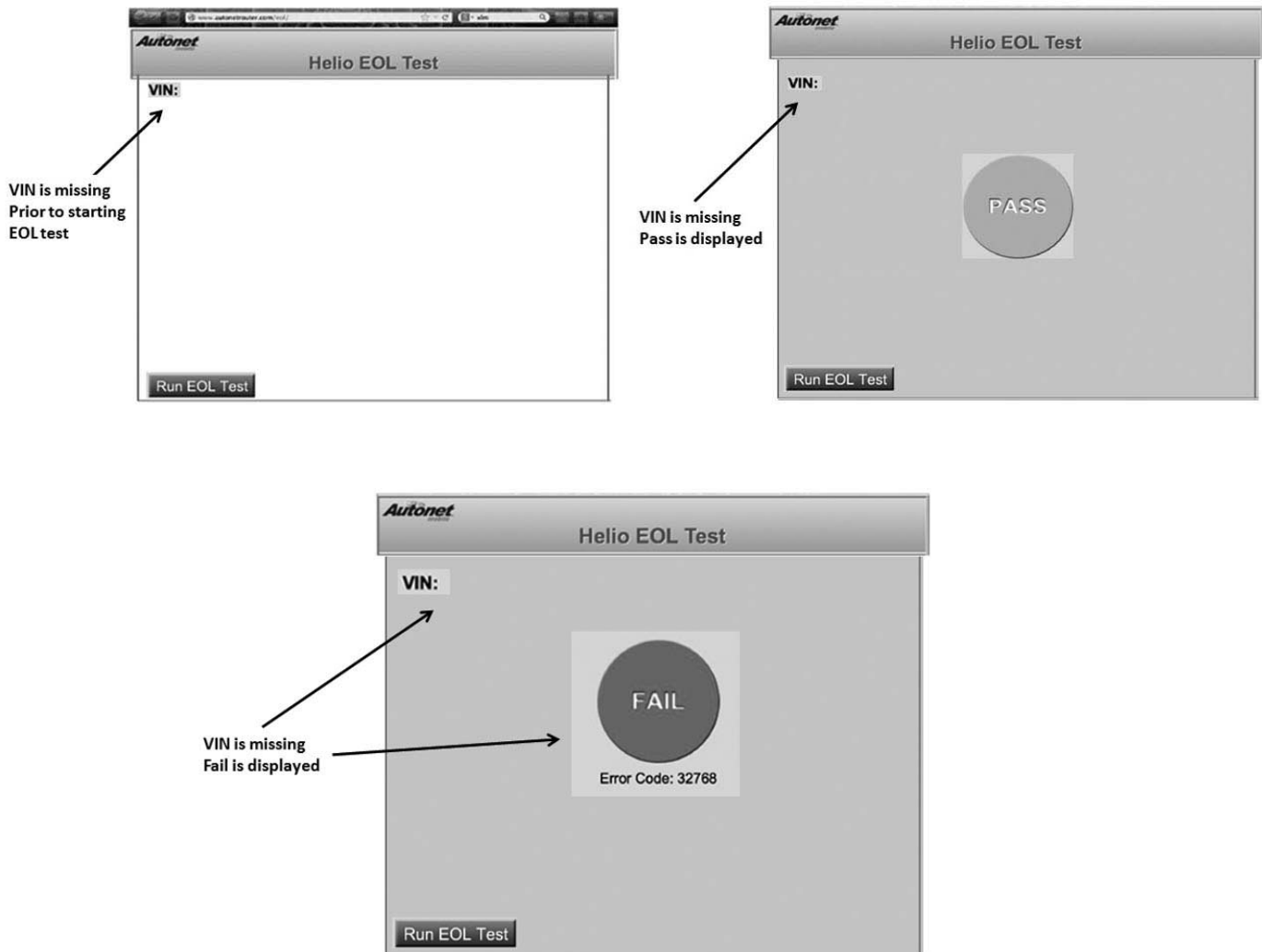

- A missing VIN indicates that the Mopar Connect is not properly connected to the vehicle's CAN bus.
- A red color Fail status displayed indicates that the network/WiFi portion of the EOL test failed.

## Mopar Connect – End Of Line (EOL) Procedure (continued)

For all other errors or for further assistance,  
contact the Autonet Mobile Customer Care Center at

**1 -855-756-6727**

and provide the Customer Care Agent with  
the error code that is displayed on the screen.

**CHECK ALL WIRING AND  
TRIM ALL CABLE TIES.**

**REVERSE STEPS 3 THROUGH 8  
TO REINSTALL ALL BODY PANELS  
AND COMPONENTS.**

**AFTER FINAL ASSEMBLY,  
CLEAR ALL FAULT CODES**

**GIVE ACTIVATION CARD TO CUSTOMER  
FOR FINAL ACTIVATION PROCEDURE.**

**29**

**30**