

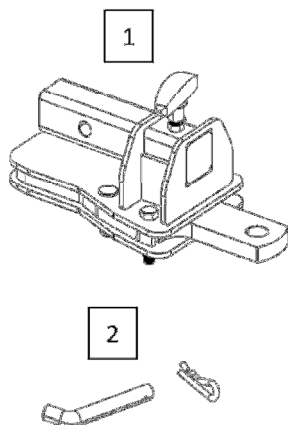

210 Series Hitches

www.mopar.com

210 Standard



210 Drop Hitch

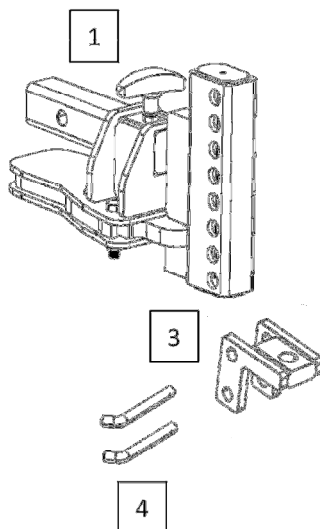

210 Accessory Channel

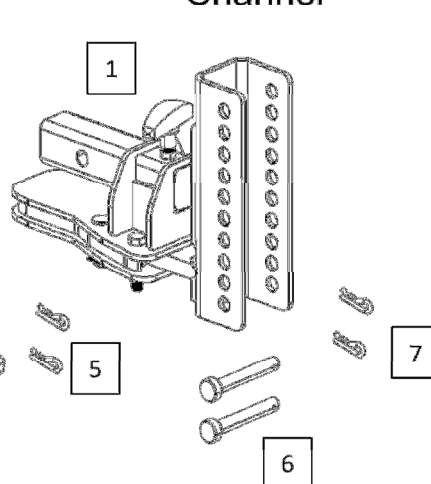

Item Number	Description	Quantity
1	Hitch	1
2	5/8" Hitch Pin Kit	1
3	Ball Mount Platform	1
4	3/4" Ball Mount Platform Pins	2
5	Ball Mount Platform Pin Safety Clips	2
6	5/8" Accessory Lock Pins	2
7	Accessory Lock Pin Safety Clips	2

Installation

- 1) Insert hitch into the 2" receiver on your vehicle.
- 2) Insert hitch pin (ref 2) through the receiver hole, and secure with hairpin clip.
- 3) **210 Standard:** attach any standard hitch ball (not included) rated for at least 7,000 pounds GTW.
- 4) **210 Drop Hitch:** attach the ball mount platform (ref 3) to the drop hitch tube at the appropriate height. Secure the ball mount platform with the pins provided (ref 4). Ensure that the pins are secured with the safety clips (ref 5) before towing. Attach any standard hitch ball (not included) rated for at least 7,000 pounds GTW
- 5) **210 Accessory Channel:** place the hitch accessory (not included) into the channel at the appropriate height setting. Secure the accessory in the channel with the pins provided (ref 6). Ensure that the pins are secured with the locking clips before towing (ref 7).

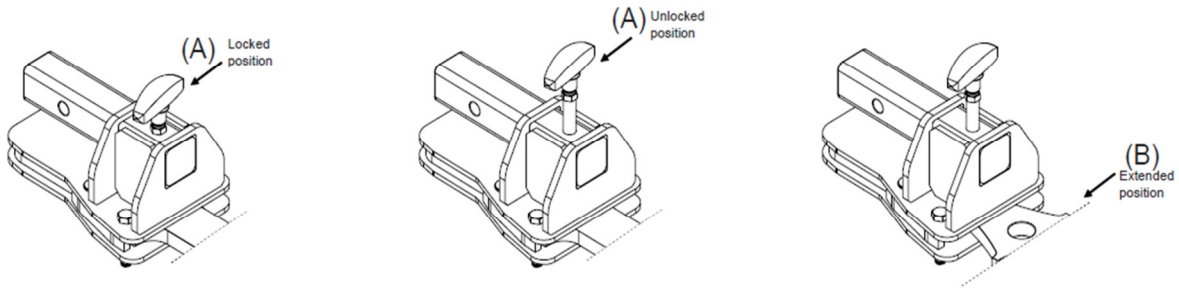

Operation: To connect to your trailer

- 1) Back up tow vehicle to get close to the trailer.
- 2) Lift up handle (ref A) to unlock.
- 3) Extend and swivel the probe (ref B) to position under the trailer coupler.
- 4) Connect and lock the trailer coupler, safety chains and electrical cords.
- 5) Lock the 210 Hitch into place by either backing into a chocked trailer or pulling slowly forward to align the tow vehicle and trailer, and applying your tow vehicle's brakes. The trailer will continue forward and lock in place. **Ensure that the locking pin is in place before towing.**

Maintenance

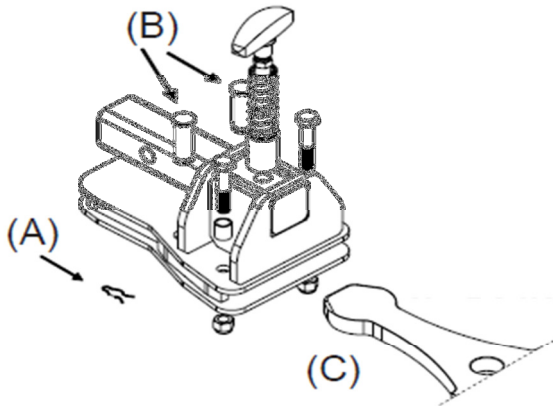

- 1) Remove the locking clips (ref A). The stop pins (ref B) will pull out from the top of the cassette.
- 2) Remove the probe (ref C) from the cassette.
- 3) Clean with soap and water, or a degreasing agent. You may find a pressure washer to be helpful in cleaning out the inside of the cassette. Ensure probe and inside of cassette are dry.
- 4) Lubricate both sides of the probe with white lithium grease.
- 5) Place the probe back in the case. Replace the stop pins (insert them from the top of the case) and secure with locking clips.
- 6) **Do not operate without stop pins securely in place.**

Safety

WARNING: Do not exceed the tow capacity of your tow vehicle. Check the owner's manual for vehicle tow ratings.

WARNING: Never use the 210 hitch system without both stop pins securely inserted and clipped in place. Failure to do so could result in serious injury or death if the trailer becomes disconnected from the hitch system.

WARNING: Do not exceed the tongue weight limits for your trailer or hitch. Always load your trailer properly.

WARNING: Do not tow with the 210 Hitch in the extended position to avoid damage to the hitch probe.