

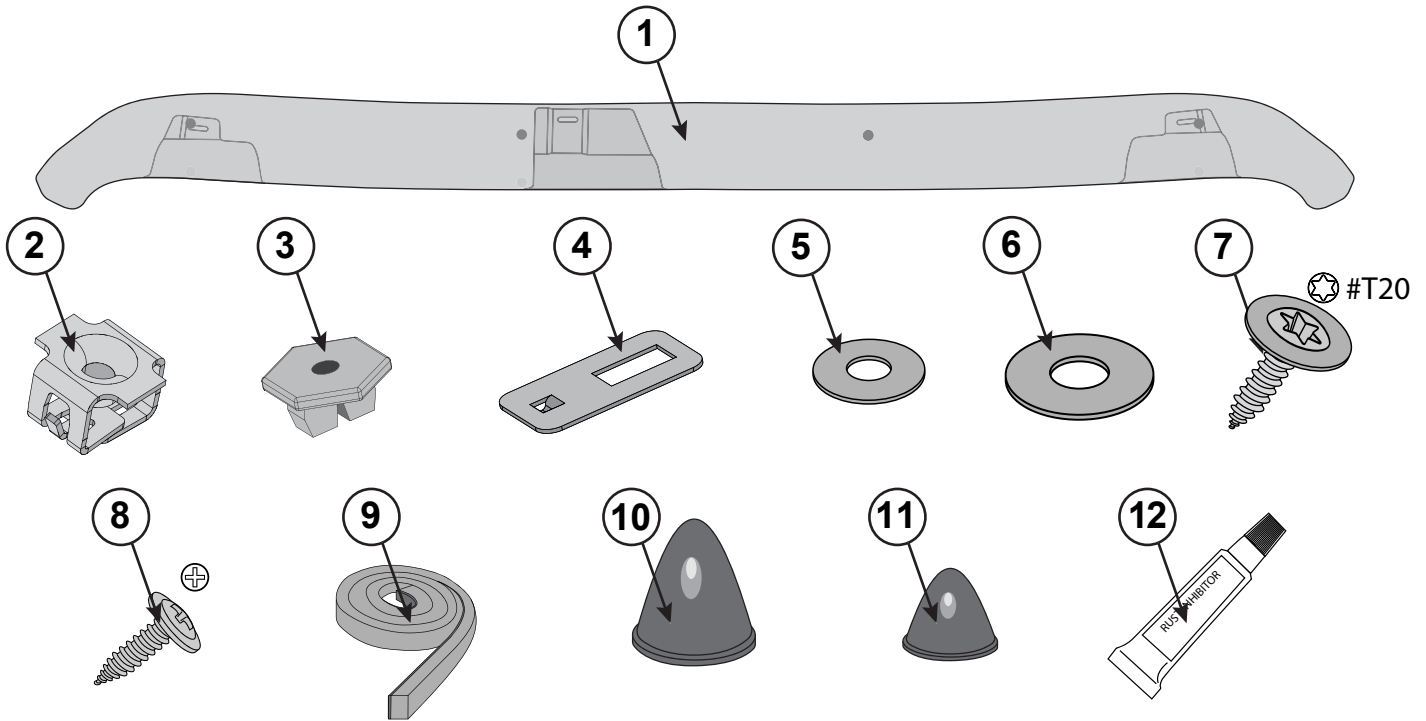

JEEP WRANGLER HOOD DEFLECTOR

www.mopar.com



Call Out	Description	Quantity	Part Number
1	Hood Deflector	1	82215367
2	Nut Insert	1	
3	Octagonal Plug	2	
4	Clip	2	
5	Small Washer	2	
6	Large Washer	1	
7	T20 Torx Screw	1	
8	Phillips Head Screw	2	
9	Foam Tape	1	
10	Large 19mm Bumpon	2	
11	Small 15mm Black Bumpon	4	
12	Rust Inhibitor	1	

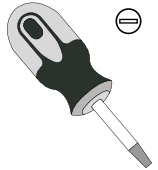
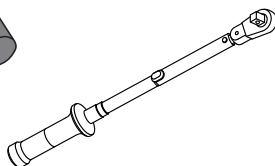
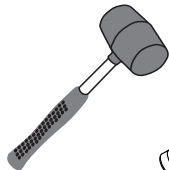

1. Open the hood.
Thoroughly clean the top and underside of the hood and surrounding areas.
Wipe away any residue and allow to completely dry.

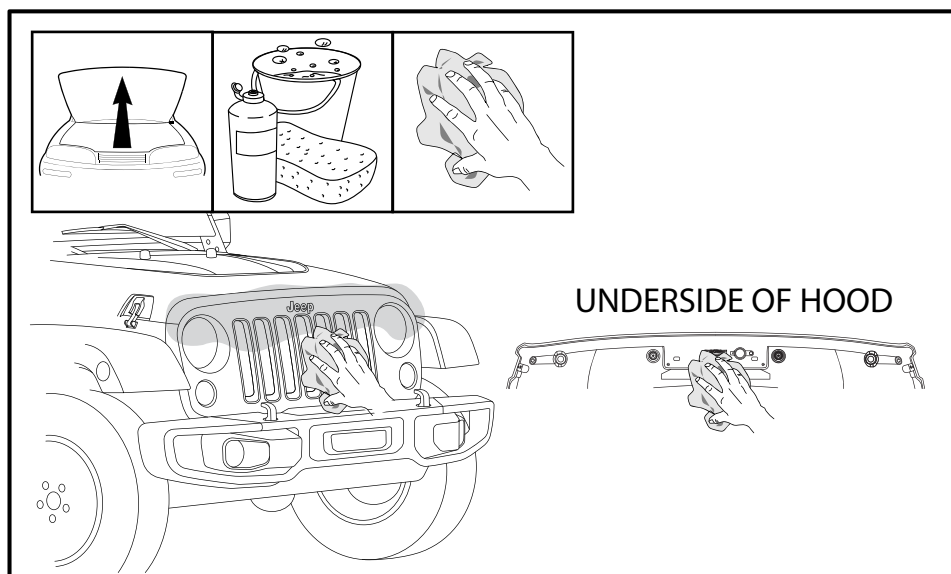

2. Peel and discard the protective tape liner from the back of the Foam Tape (9) and adhere the Foam Tape (9) to the top of the vehicle grille. Ensure front edge of foam is against grille radius.

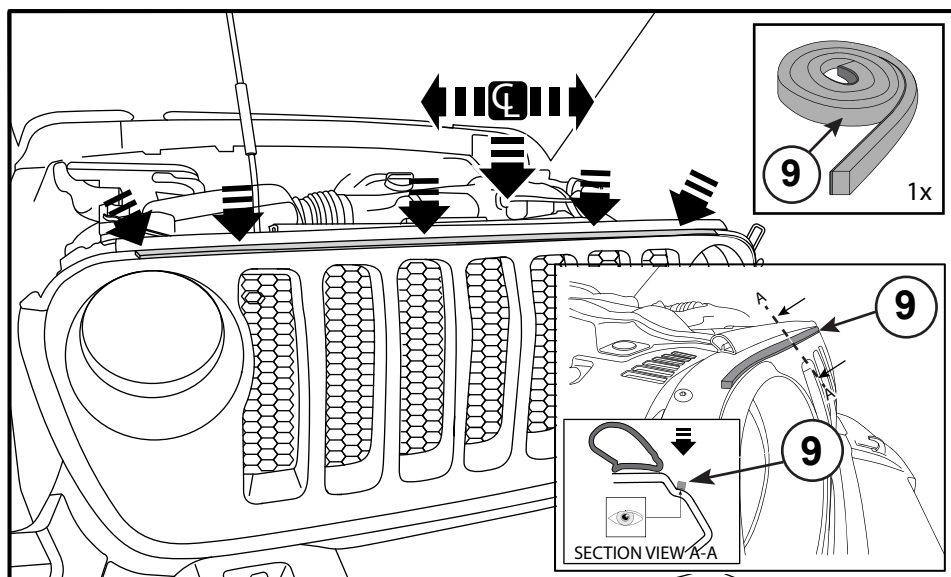

3. Trial fit the Hood Deflector.

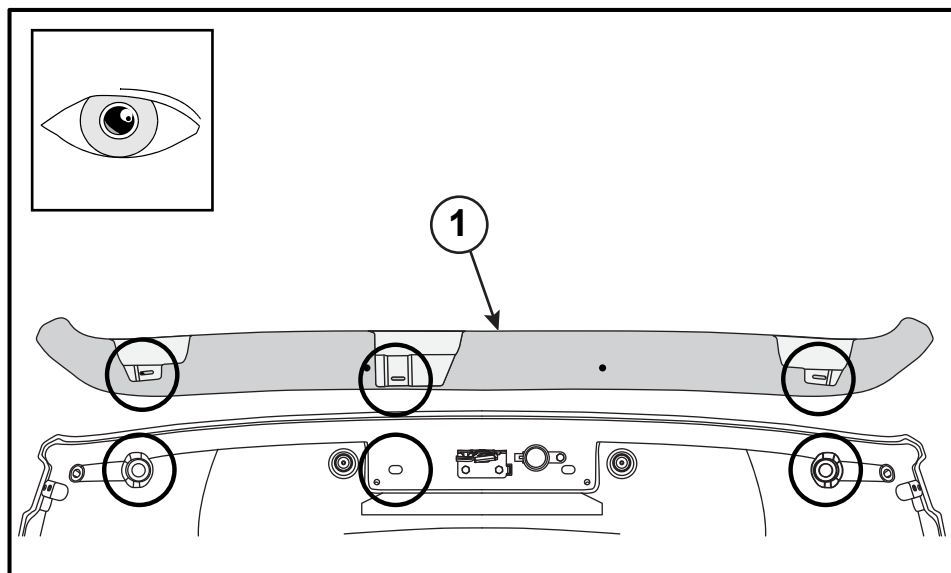

4. Slide a clip (4) into each hole and ensure that the hook is engaged under the sheet metal.

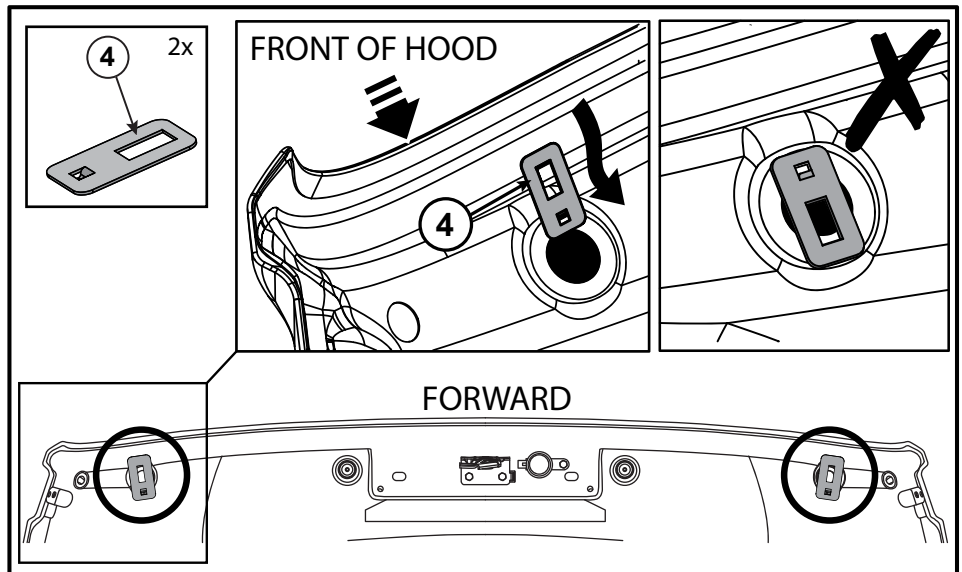

5. Tap the clip with a screwdriver to push it so that the hook is fully seated on the hood.

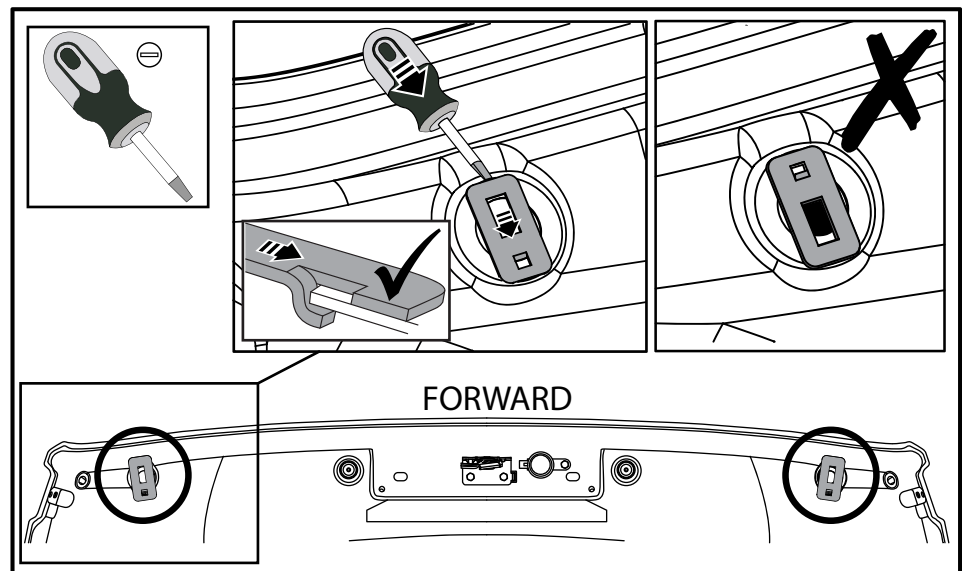

6. Align the octagonal plug (3) with the rectangular hole and press it into the clip as shown.

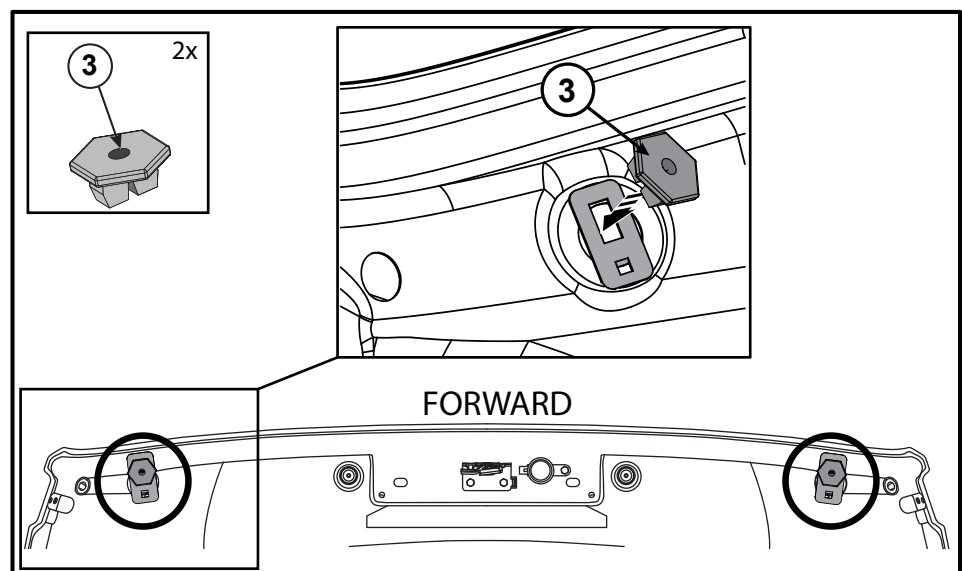

7. Apply rust inhibitor (12) to the centre rectangular slot in the hood. Allow 2 minutes for rust inhibitor to dry. Fit the square nut insert (2) into it the slot as shown using a rubber mallet to seat the plug flush against the hood.

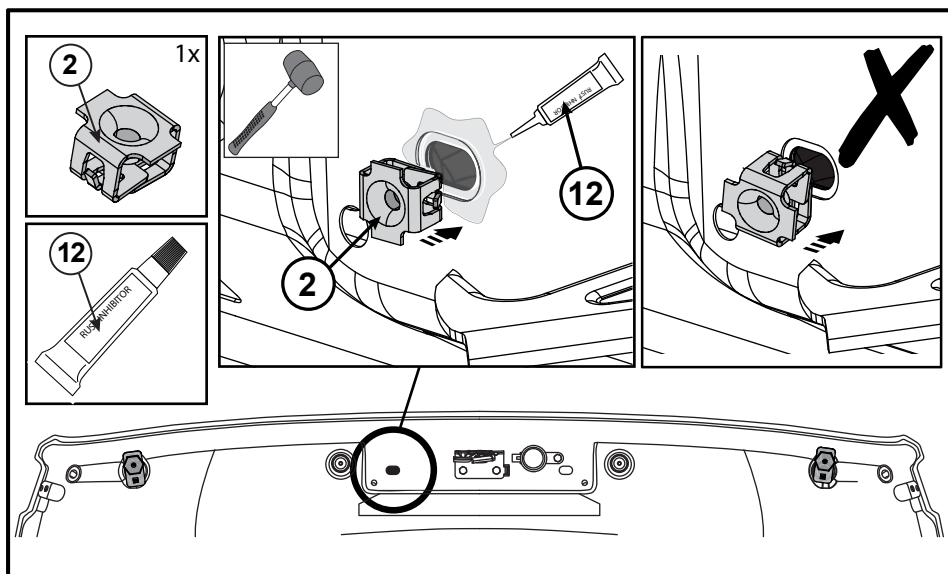

8. Re-fit the Hood Deflector (1).

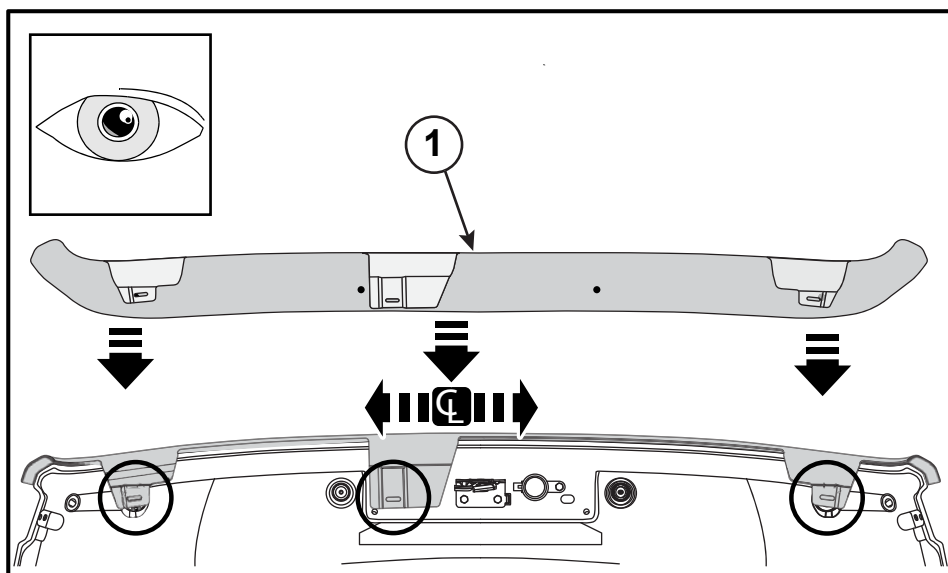

9. Secure the central tag of the Hood Deflector with the T20 screw (7) and large washer (6).

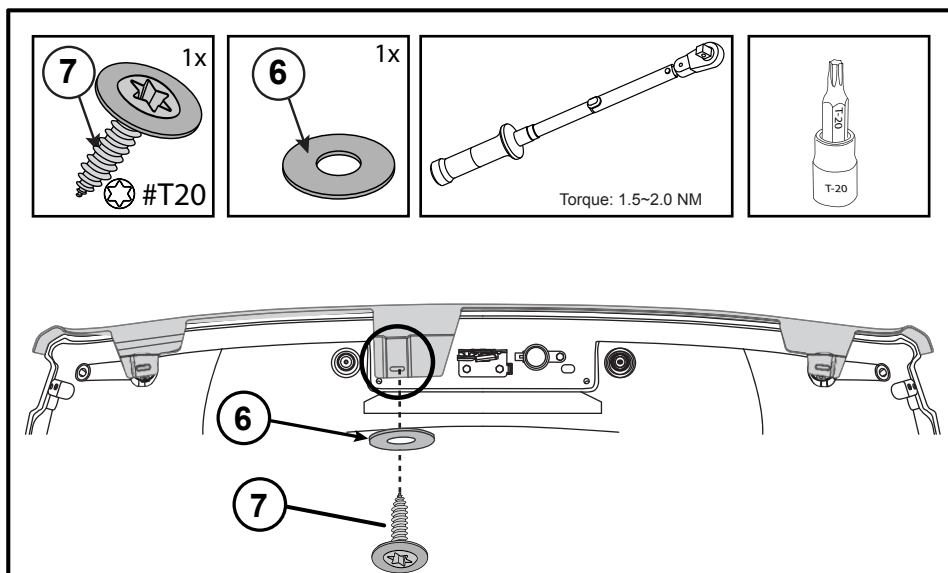

10. Secure the outer tags of the Hood Deflector with the philips head screws (8) and small washers (5) provided.

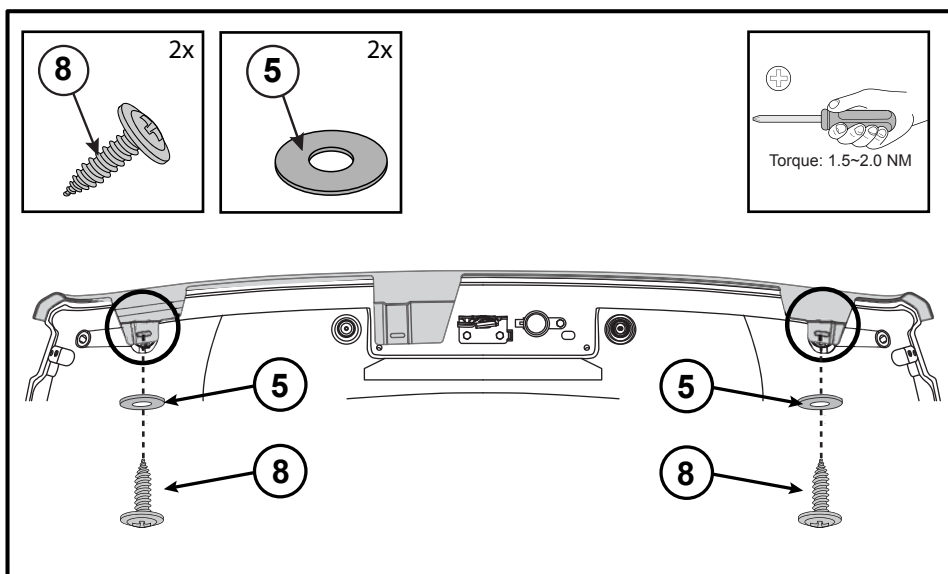

11. Close the hood.

At the four bumpon positions which are indicated by the small bumpon location stickers on the Hood Deflector, adhere a bumpon directly to the hood underneath each sticker.

Peel off and discard the bumpon location stickers when complete.

Note: Use the correct bumpons at the noted locations.

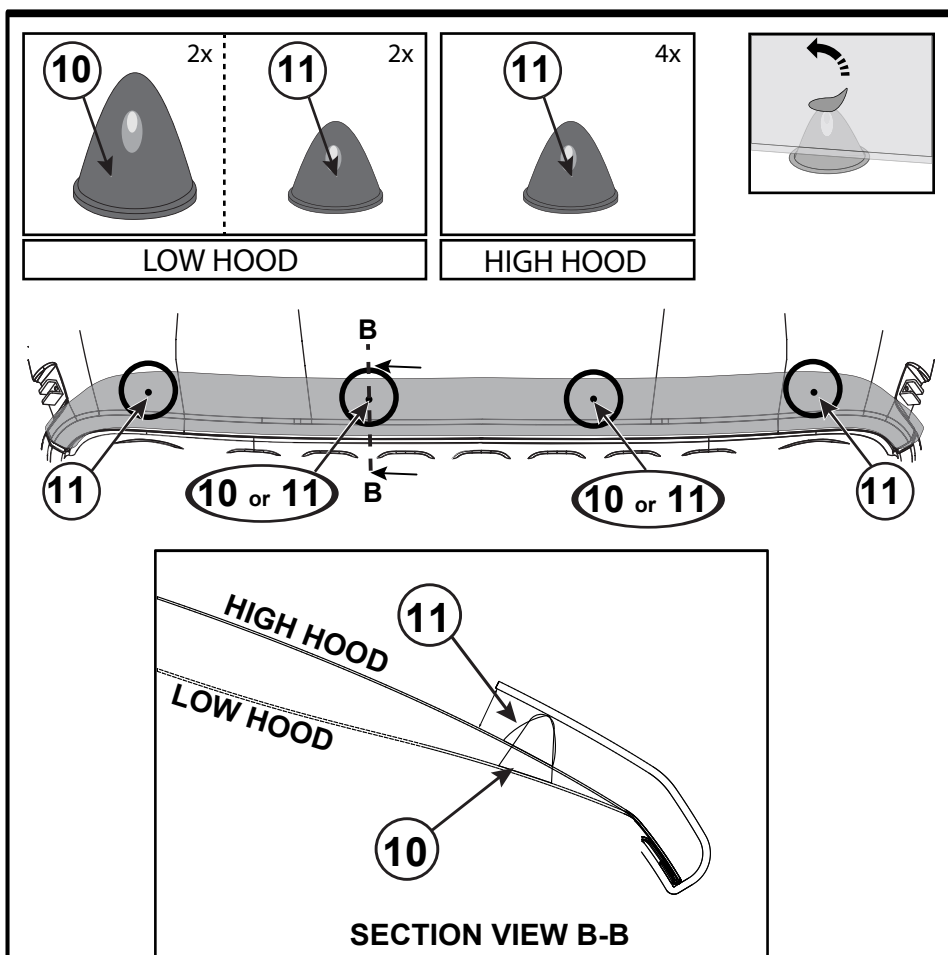

Note: If distance from hood to deflector is 15 mm or less, use Small Bumpon (11). If distance from hood to deflector is greater than 15 mm, use Large Bumpon (10).



JEEP WRANGLER

Deflector de Capó

www.mopar.com

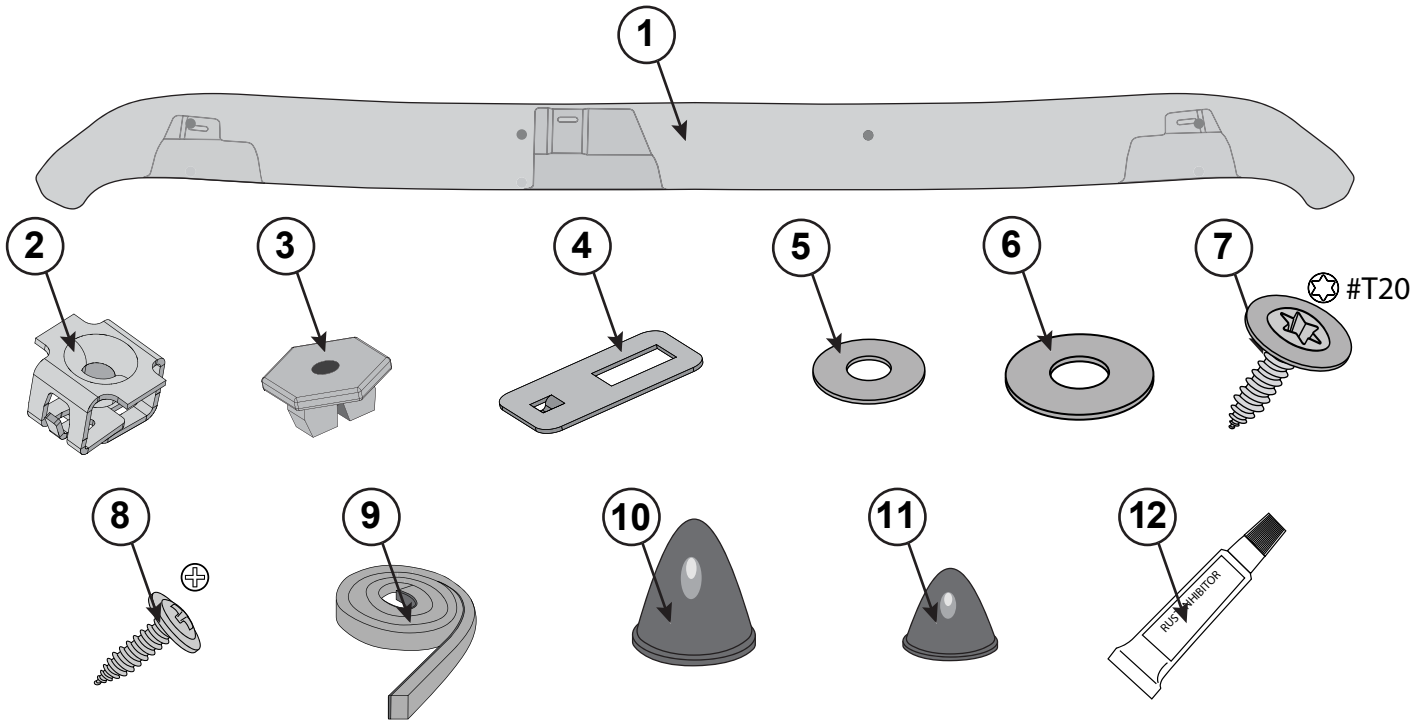

Call Out	Description	Quantity	Part Number
1	Deflector de Capó	1	82215367
2	Inserción de Tuerca	1	
3	Inserción Octagonal	2	
4	Soporte Metalico	2	
5	Arandela Pequeña	2	
6	Arandela Grande	1	
7	Tornillo Cabeza Torx	1	
8	Tornillo Cabeza Phillips	2	
9	Cinta Adhesiva	1	
10	Bumpon Grande 19 mm	2	
11	Bumpon Pequeña 15mm	4	
12	Inhibidor de Herrumbre	1	

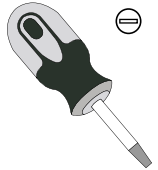
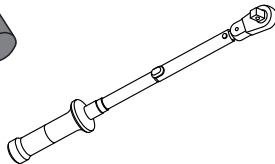
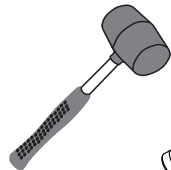

1. Abre el capó. Limpia a fondo la parte superior y interior de el capó y áreas adyacentes. Limpie cualquier residuo y deja secar completamente.

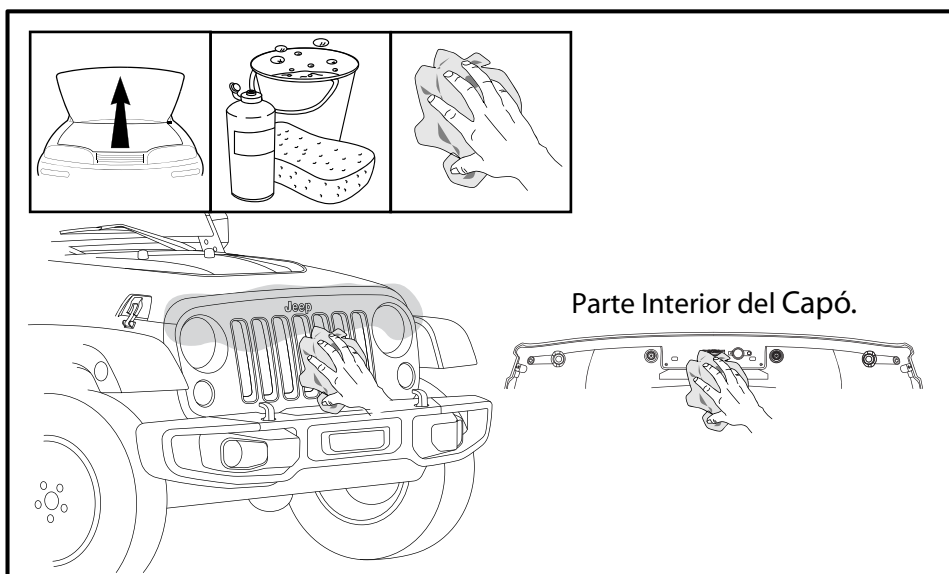

2. Pela y descarta el forro de la Cinta Protectora (9) y adhiere la Cinta Protectora (9) a la parte superior de la parrilla del vehículo. Asegúrese que el borde delantero de la cinta esté contra el radio de la rejilla.

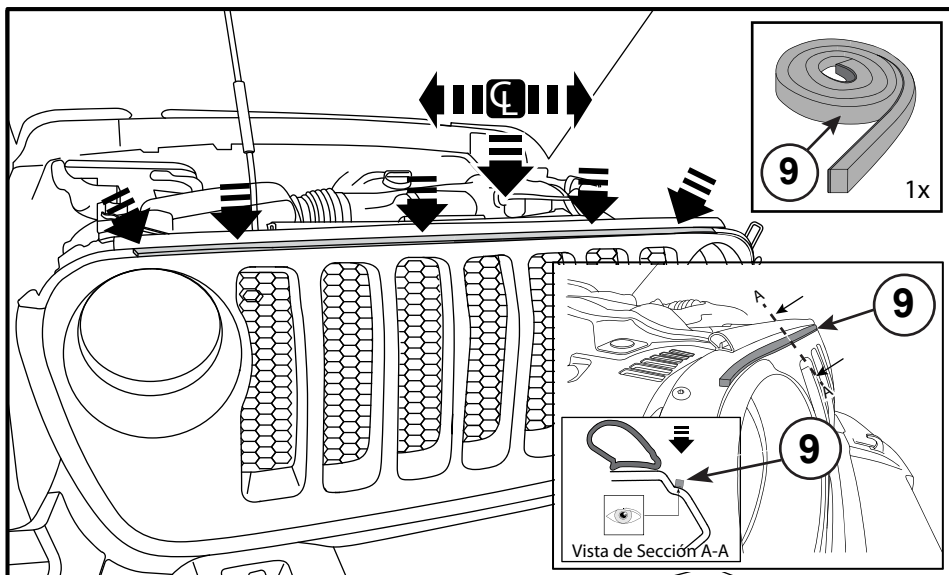

3. Ajuste de prueba el Deflector de capó.

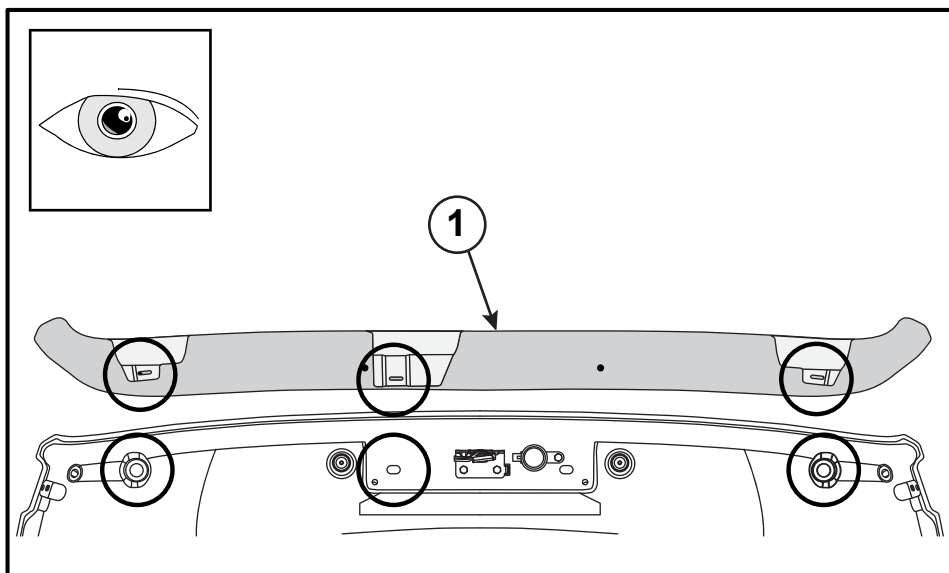

4. Deslice un Soporte Metalico (4) en cada agujero y asegúrese de que el gancho esté seguro debajo de la chapa de metal.

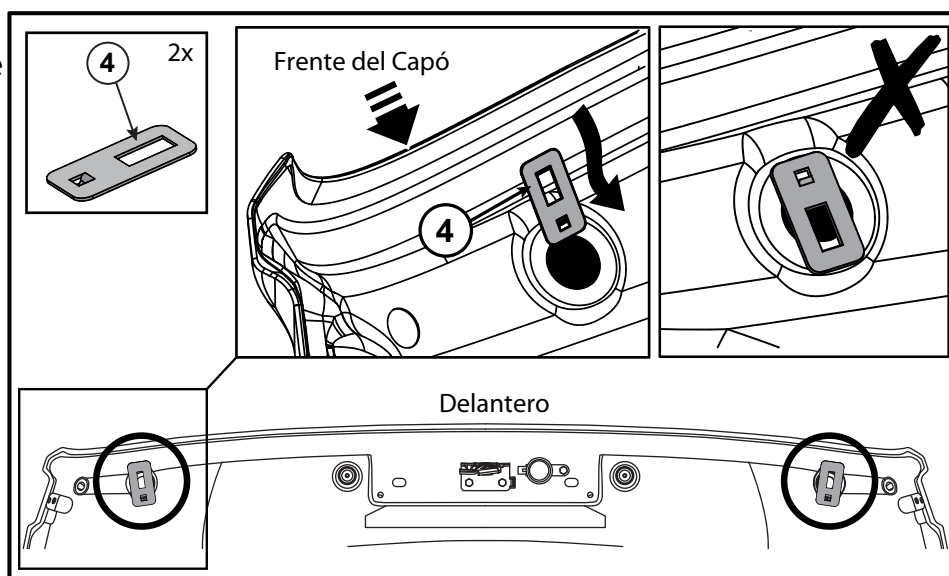

5. Empuja el Soporte Metalico (4) con un destornillador para que el gancho quede completamente sentado en el agujero.

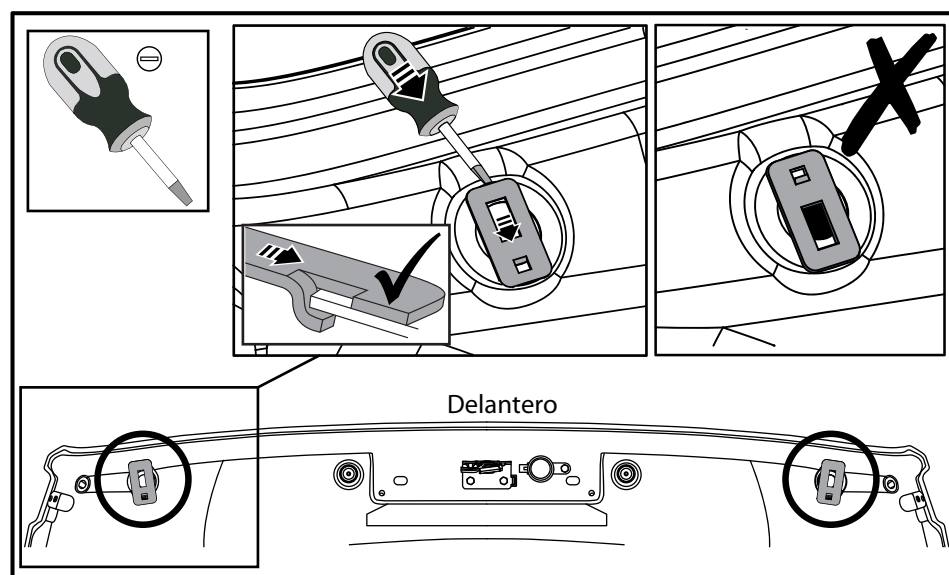

6. Alinee la Inserción Octogonal (3) con el agujero rectangular y presiónalo en el Soporte Metalico (4) como se muestra.

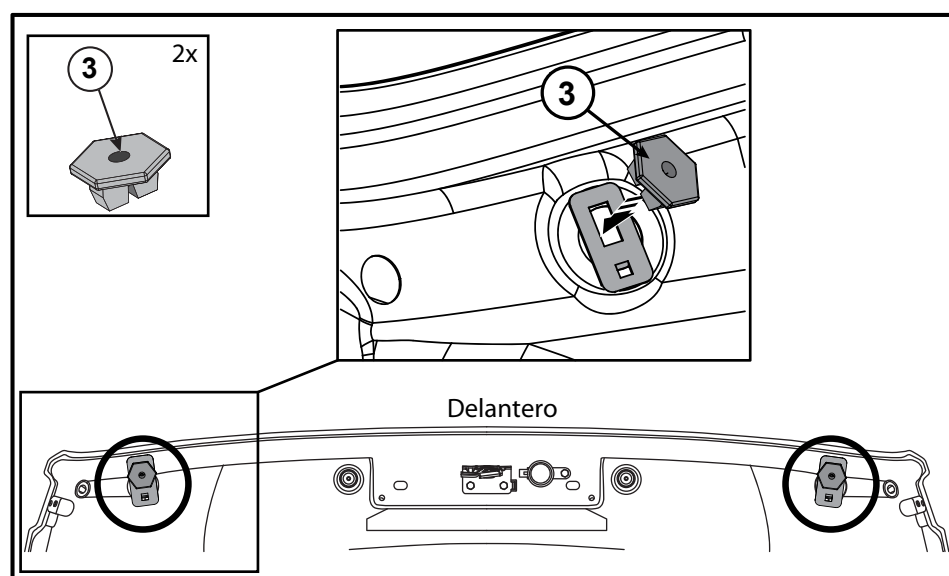

7. Aplique Inhibidor de Herrumbre (12) al agujero rectangular central del capó. Permita 2 minutos para que el Inhibidor de Herrumbre (12) se seque. Coloque la Inserción de Tuerca (2) en el agujero como se muestra usando un mazo de goma para asentar la Inserción de Tuerca (2) al ras contra el capó.

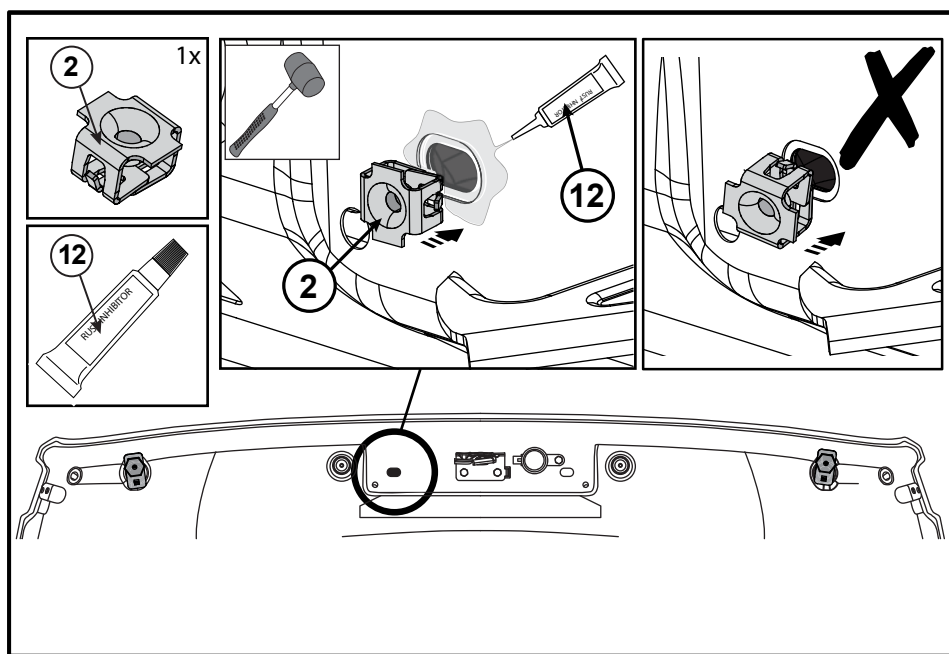

8. Vuelva a ajustar el Deflector de Capó (1).

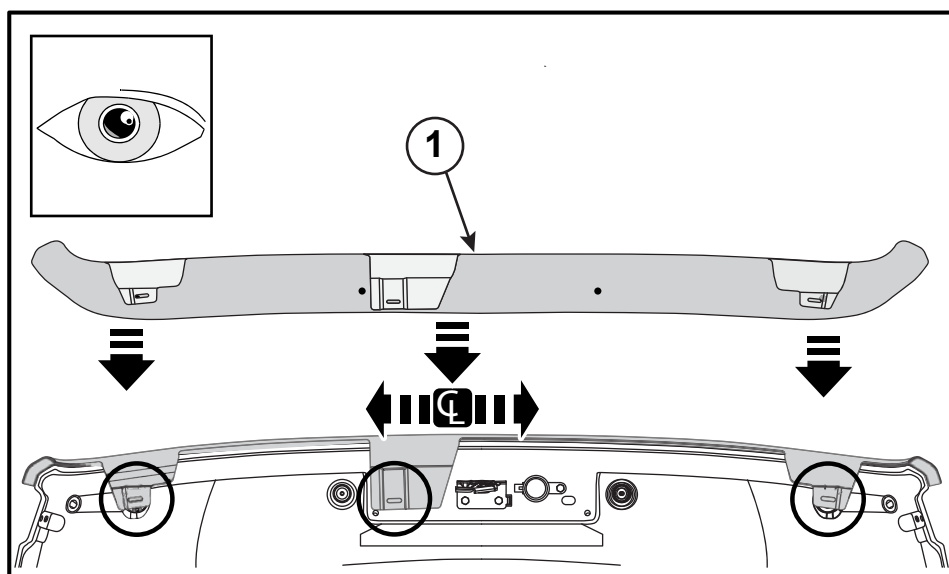

9. Asegure la etiqueta central del Deflector de Capó con el Tornillo Cabeza Torx (7) y Arandela Grande (6).

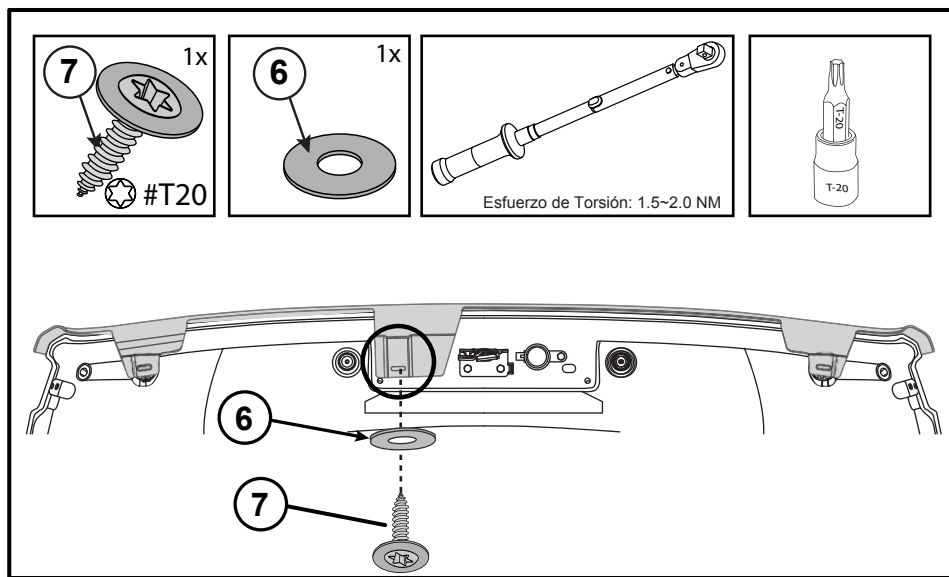

10. Asegura las etiquetas externas del Deflector de Capó (1) con los Tornillos Cabeza Phillips (8) y Arandelas Pequeños (5).

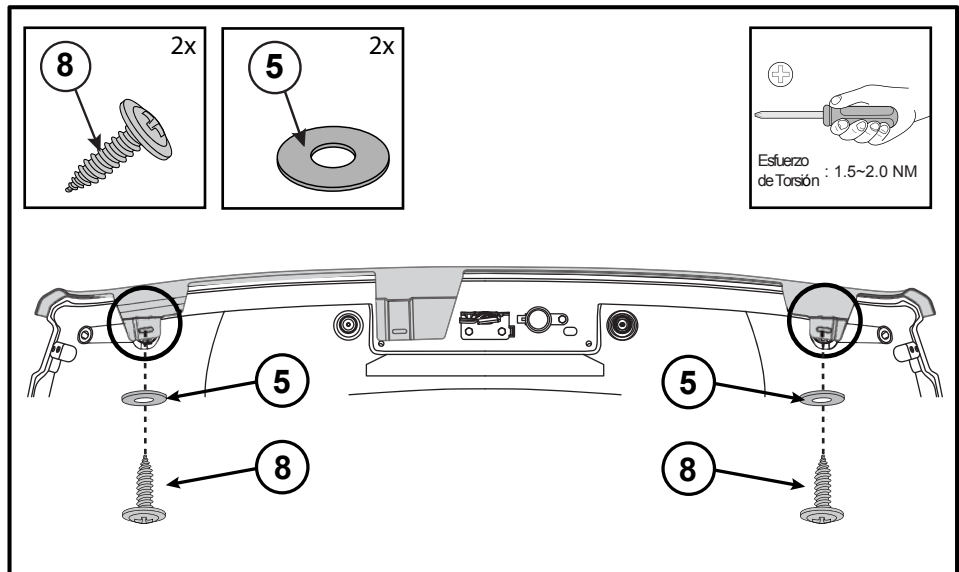

11. Cierra el Capó.

En las cuatro posiciones de bumpon que están indicados por las etiquetas de ubicación en el Deflector de Capó (1), adhiere un Bumpon (10,11) directamente al Capó debajo de cada etiqueta. Despega y descarta las etiquetas de ubicación de bumpon cuando estén completas.

Nota: Usa los bumpones correctos en los lugares señalados.

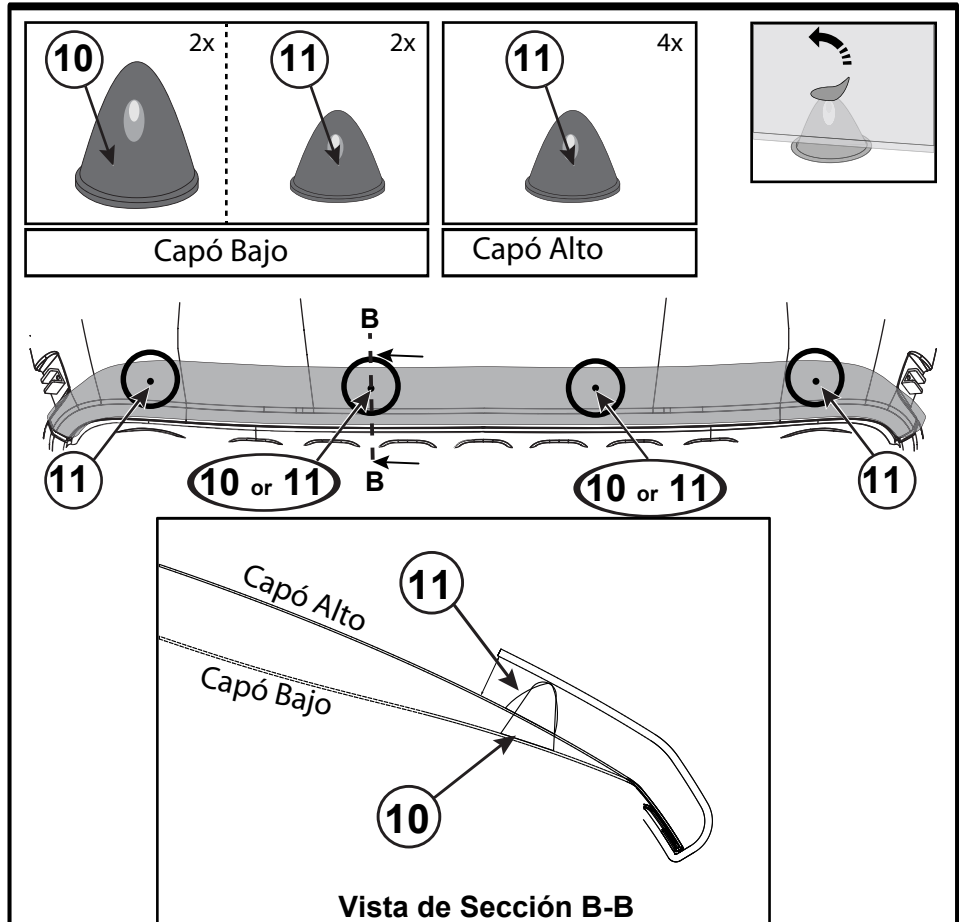

Nota: Si la distancia del capó al deflector es de 15 mm o menos, use el Bumpon Pequeño (11). Si la distancia del capó al deflector es más de 15 mm, use el Bumpon Grande (10).



JEEP WRANGLER

Défecteur de Capot

www.mopar.com

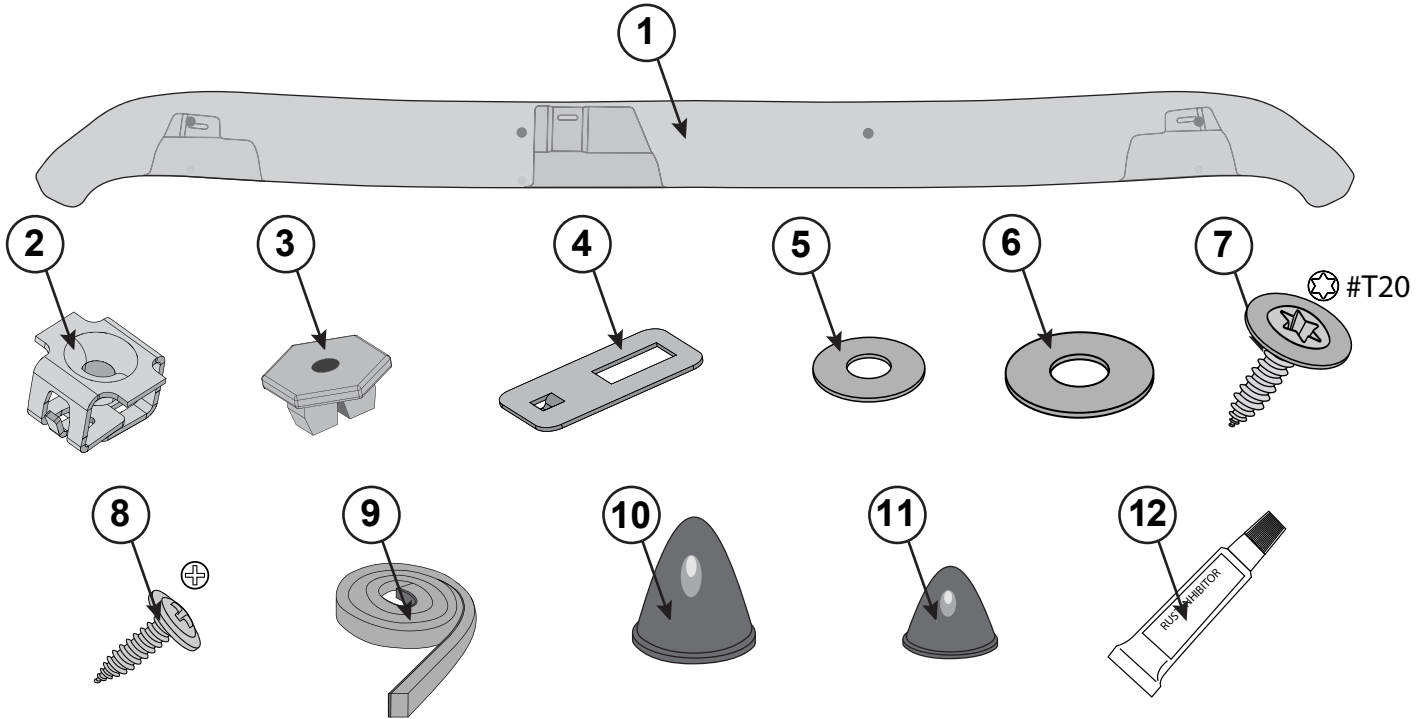

Call Out	Description	Quantity	Part Number
1	Défecteur de Capot	1	82215367
2	Écrou Insérez	1	
3	Octogonale Insérez	2	
4	Support Métallique	2	
5	Petite Rondelle	2	
6	Grande Rondelle	1	
7	Vis à Tête Torx	1	
8	Vis à Tête Cruciforme	2	
9	Ruban Adhésif	1	
10	Grand Bumpon 19 mm	2	
11	Petit Bumpon 15mm	4	
12	Inhibiteur de Rouille	1	

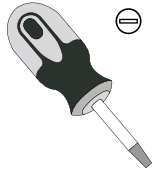
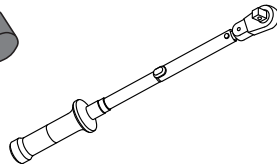
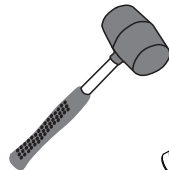

1. Ouvrez le capot. Nettoyer soigneusement le haut et dessous du capot et les environs. Essayez tout résidu et laissez sécher complètement.

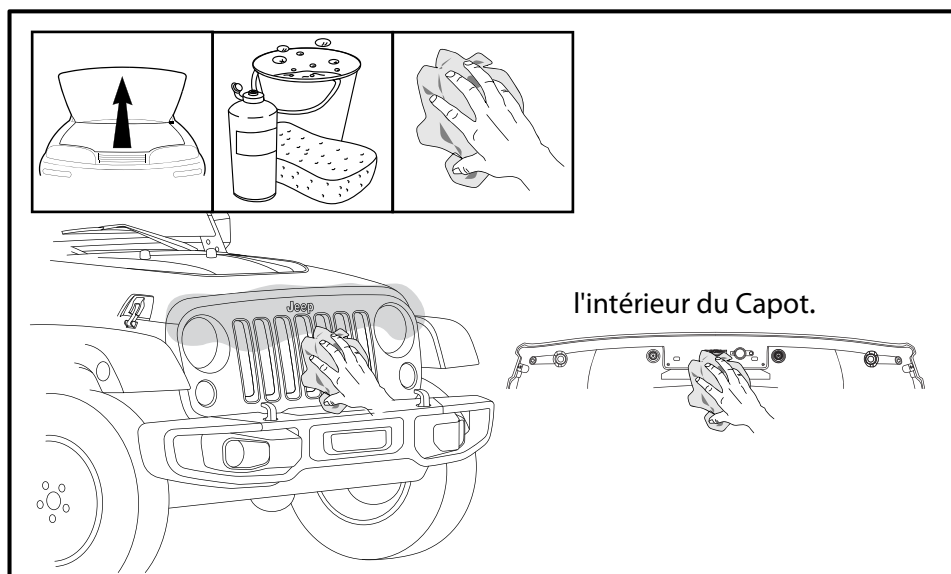

2. Peler et jeter la doublure de protection de l'arrière de la Ruban Adhésif (9) et collez le Ruban Adhésif (9) au sommet de la calandre du véhicule. Assurez-vous que le bord avant de la ruban est contre le rayon de la grille.

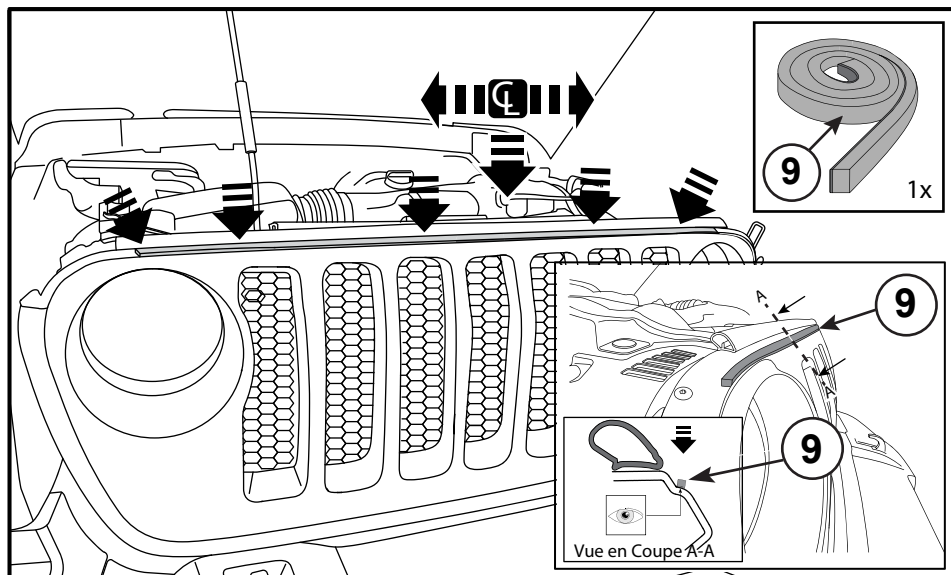

3. Essai d'ajustement du déflecteur de capot.

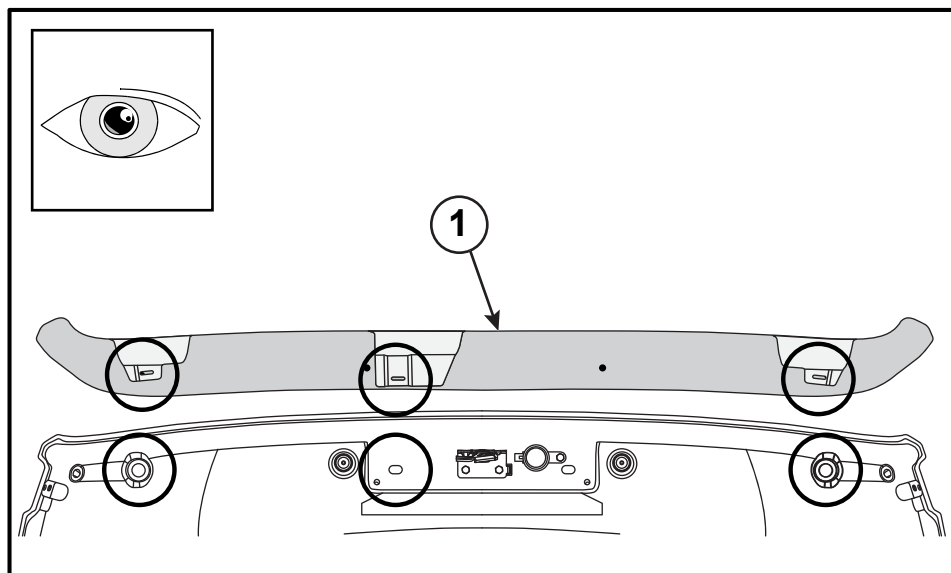

4. Glissez un Support Métallique (4) dans chaque trou et assurez-vous que le crochet est engagé sous la tôle.

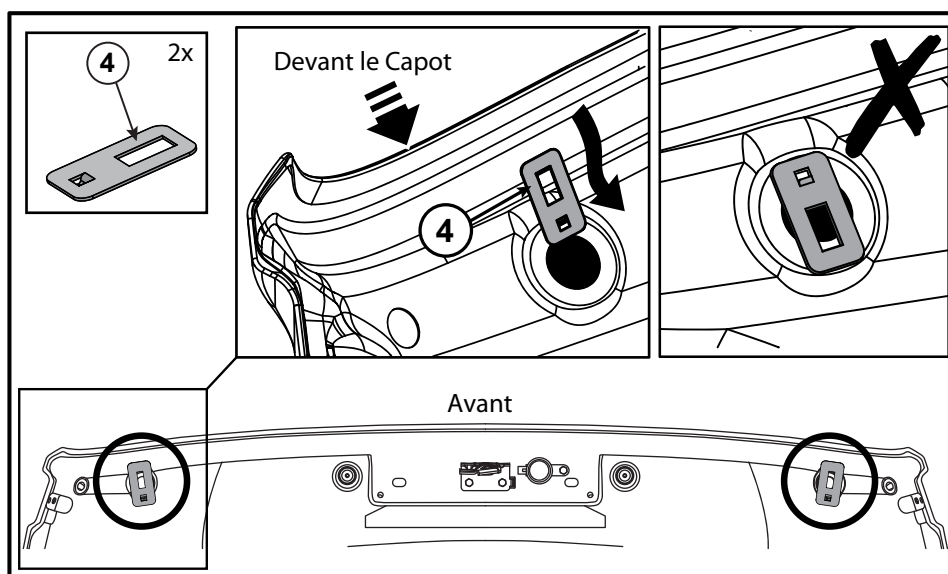

5. Appuyez sur le Support Métallique (4) avec un tournevis pousser pour que le crochet soit entièrement assis sur le capot.

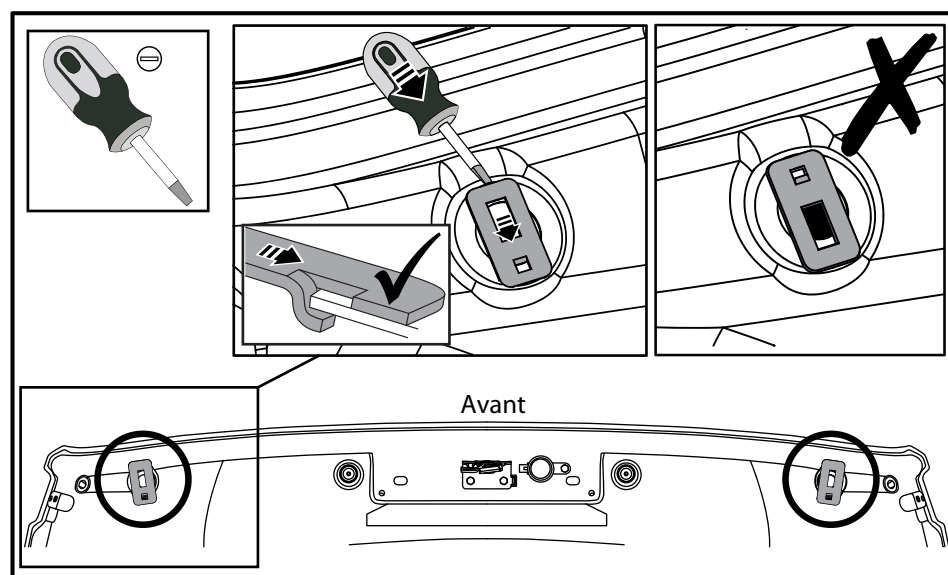

6. Aligner la Octogonale Insérez (3) avec le trou rectangulaire et Enfoncez-le dans le Support Métallique (4) comme indiqué.

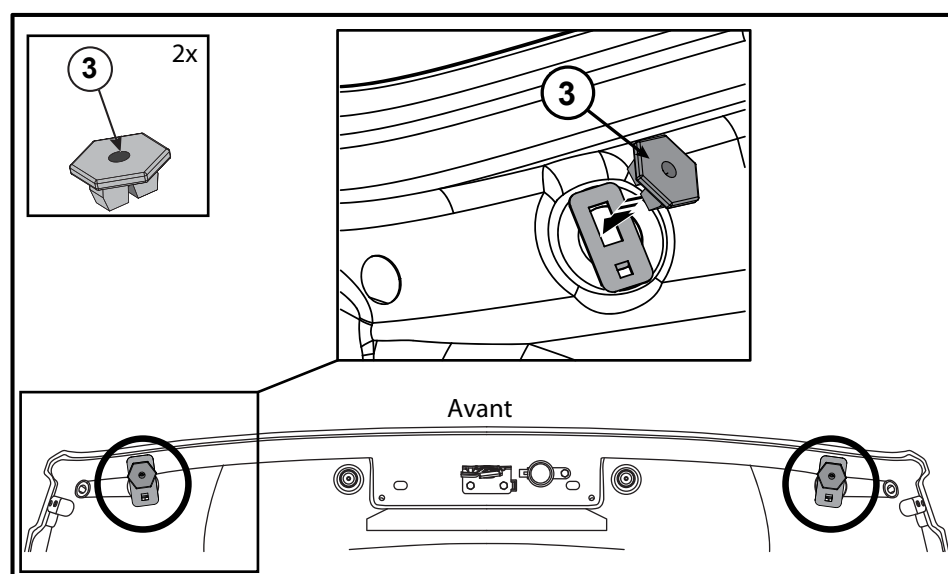

7. Appliquer l'Inhibiteur de Rouille (12) fente rectangulaire centrale dans le capuche. Attendre 2 minutes pour que l'inhibiteur de rouille sèche. Monter l'Écrou Insérez (2) dans la fente comme indiqué en utilisant un maillet en caoutchouc pour asseoir le prise de courant contre le capot.

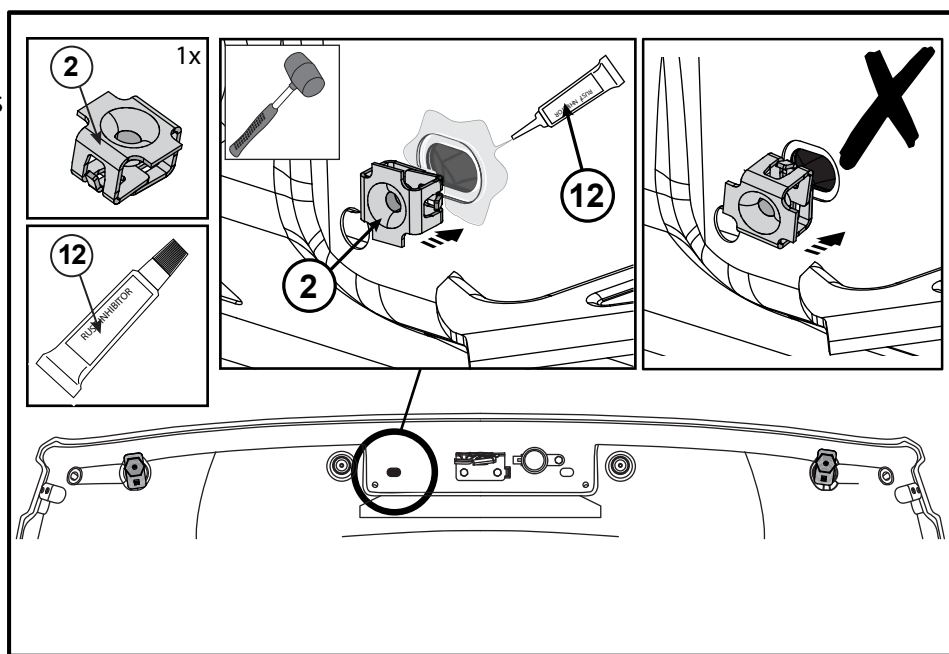

8. Réinstallez le Déflecteur de Capot (1).

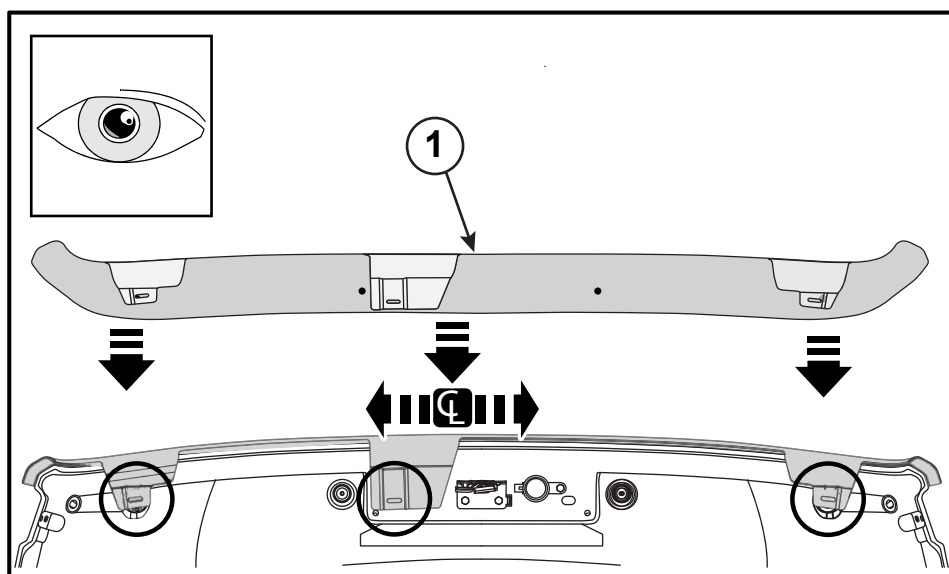

9. Sécurisez l'étiquette centrale de le déflecteur de capot avec le Vis à Tête Torx (7) et Grande Rondelle (6).

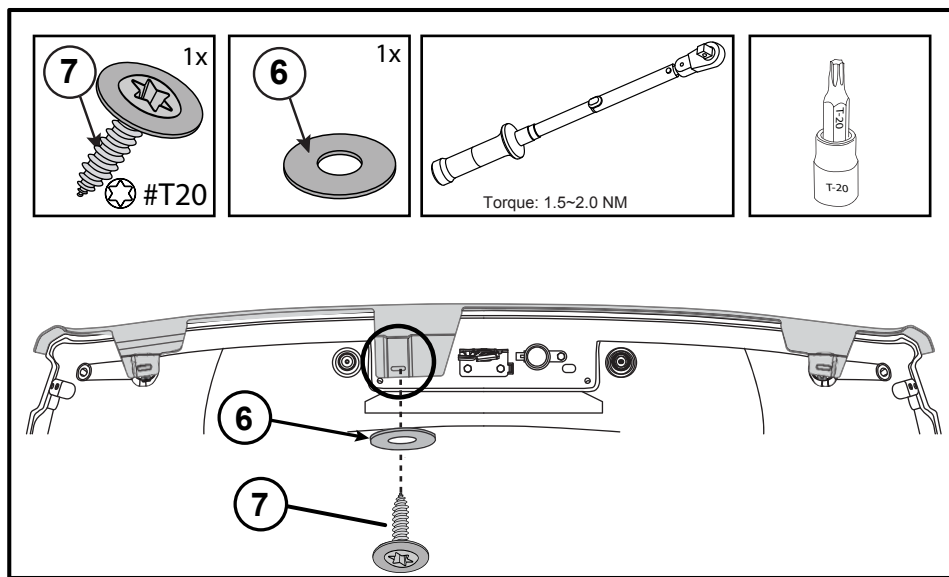

10. Sécurisez les étiquettes externes de Déflecteur de Capot (1) avec les Vis à Tête Cruciforme (8) et Petite Rondelles (5).

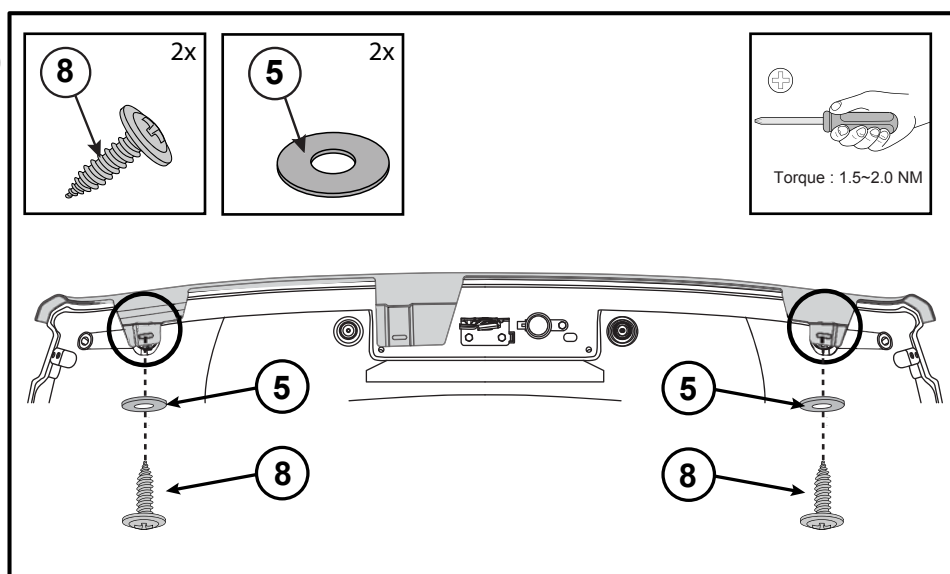

11. Fermez le capot.

Aux quatre positions de bumpon qui sont indiqués par le petit autocollants de localisation de bumpon sur le Déflecteur de Capot, adhérer à Bumpon directement sur le capot sous chaque autocollant. Décoller et jeter le bumpon autocollants de localisation une fois complétés.

Note: Utilisez les bons bumpons aux endroits indiqués.

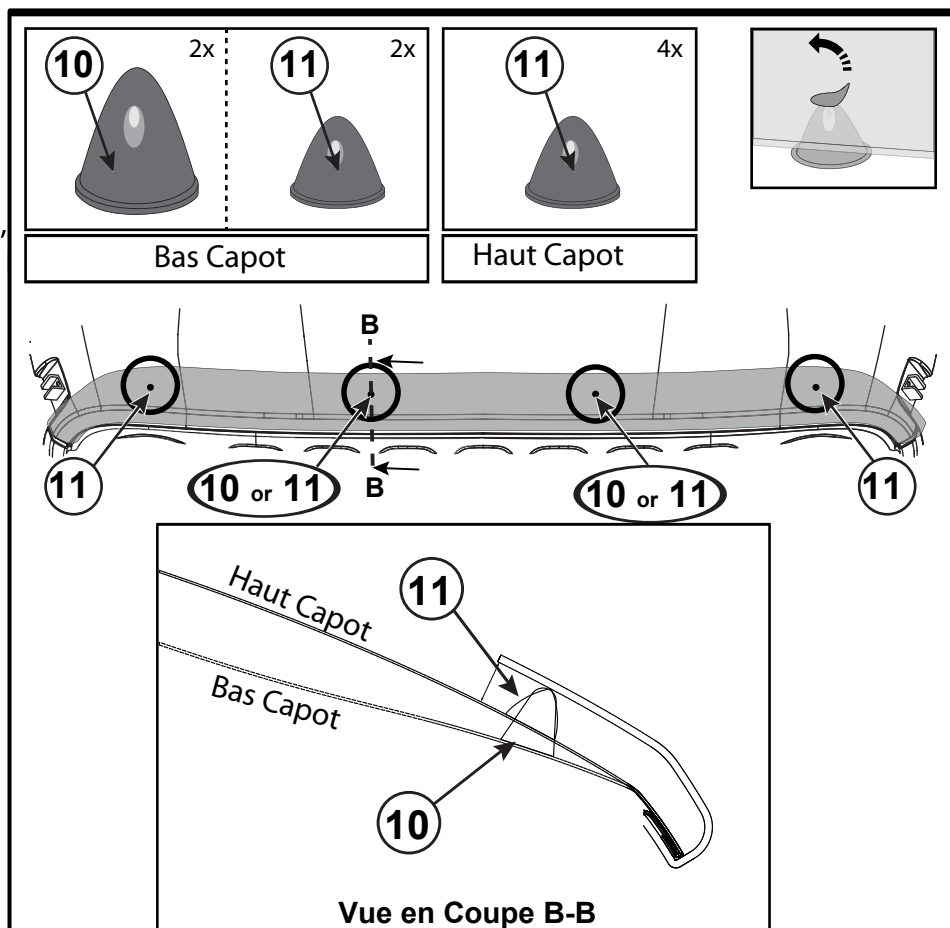

Note: Si la distance entre le capot et le déflecteur est de 15 mm ou moins, utilisez Petit Bumpon (11). Si la distance entre le capot et le déflecteur est plus grand que 15 mm, utilisez Grand Bumpon (10).