

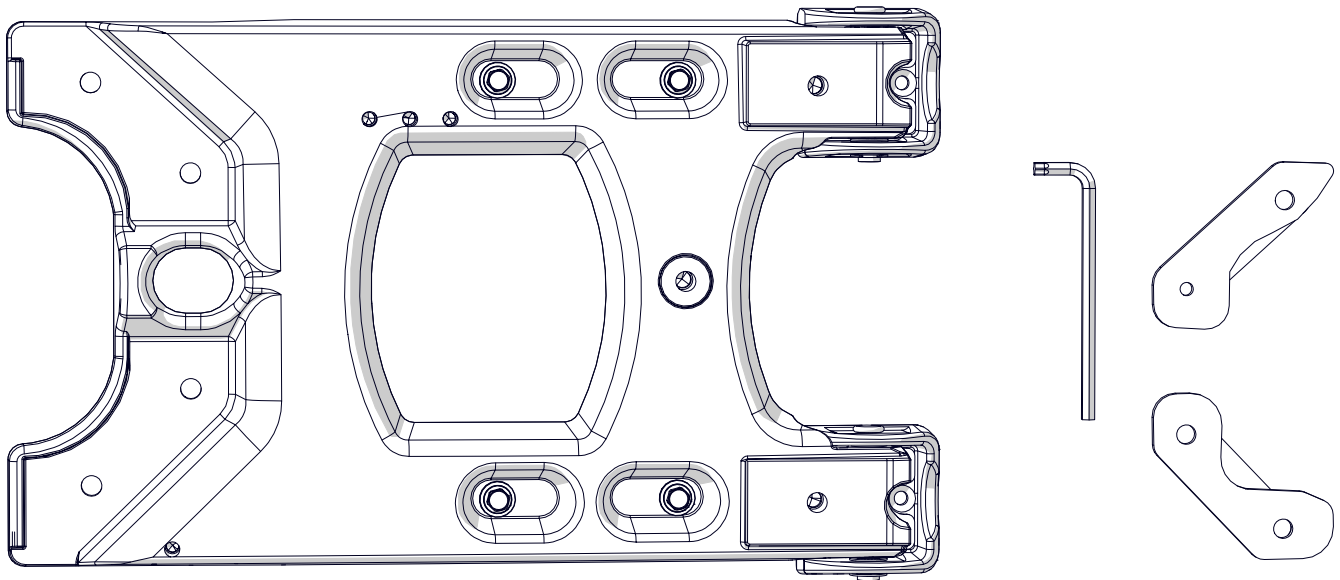

CAST TAILGATE & HINGE REINFORCEMENT KIT

www.mopar.com



Important Notes:

Prior to beginning this or any installation read these instructions to familiarize yourself with the required steps and evaluate if you are experienced and capable to personally perform these modifications. A factory service manual should be used in conjunction with these installation instructions.

Refer to the parts list to ensure that all necessary components and hardware has been included. If any parts are missing please contact your local Jeep dealership for assistance.

Tools needed:

- Lug Wrench
- T50 Torx driver (included)
- T20 Torx driver
- 13 mm socket
- 12 mm socket
- Ratchet
- Blue thread locking compound
- Spacer that will fit between your Jeep's bumper and the bottom of the tail gate (soft material such as wood is recommended to avoid damaging the vehicle's paint)

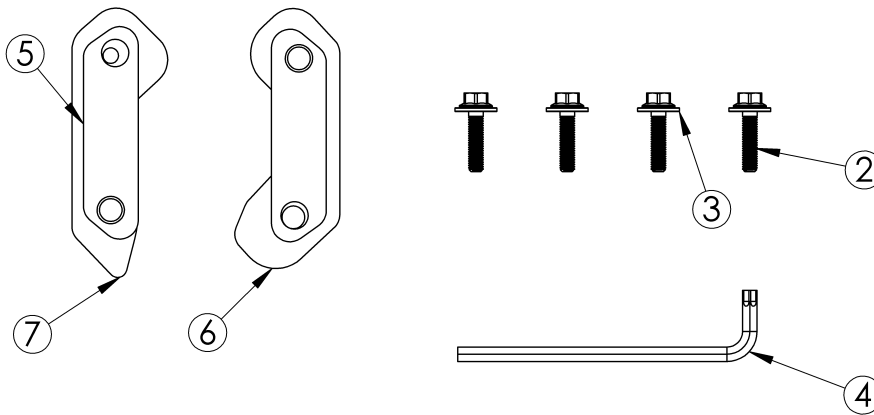
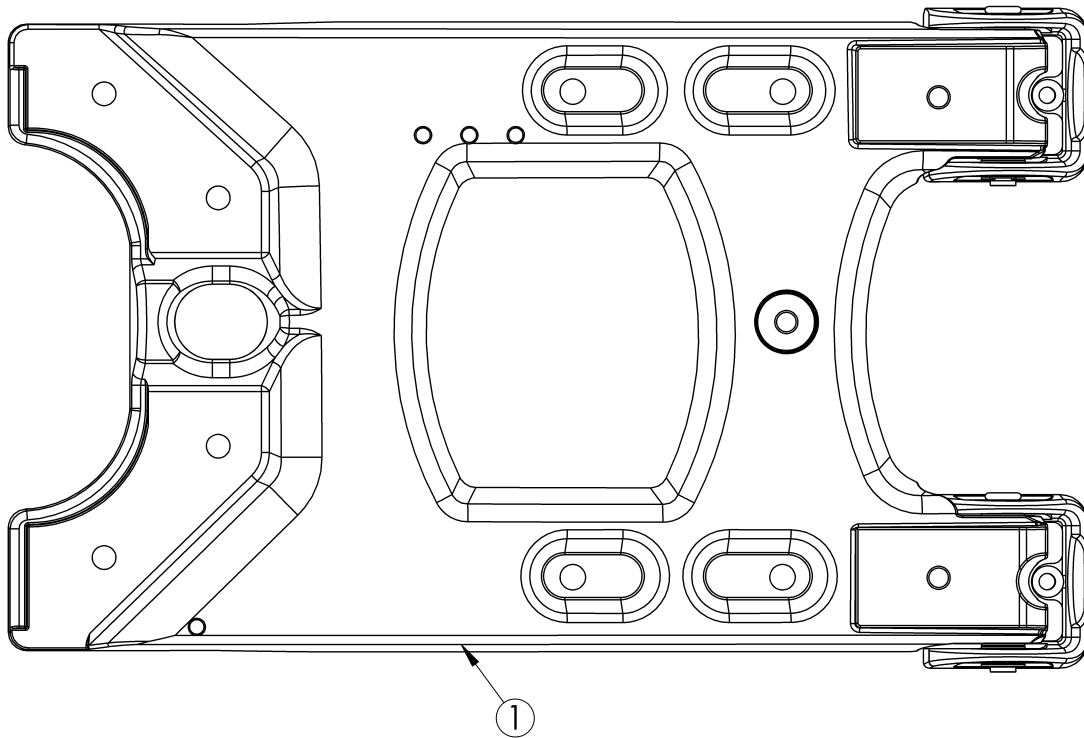

Call Out	Description	Quantity	Part Number
1	Aluminum JK Hinged Tire Carrier	1	838175
2	M8 x 1.25 P x 35mm Long Grade 10.9 Bolt	4	209
3	M8 Flat Washer	4	23
4	T50 Torx Key	1	387
5	Spacer Plate Gasket	2	610039
6	Lower Spacer Plate	1	838104
7	Upper Spacer Plate	1	838105

IMPORTANT: Do not remove the factory tailgate hinges until instructed to do so. Precisely following these instructions will help avoid any tailgate adjustment and misalignment issues. Ensure the tailgate is closed tightly and do not open it during installation.

1



2



3

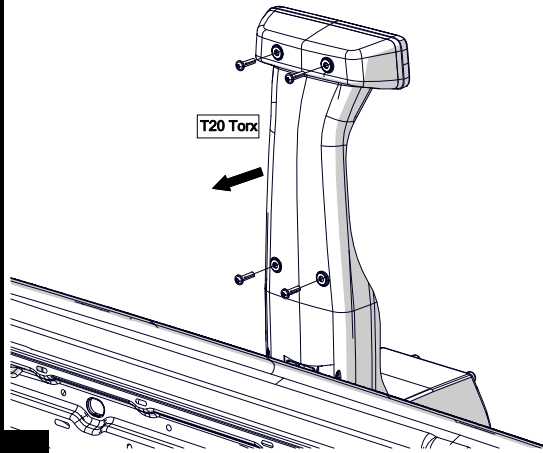

4

Unplug light connector

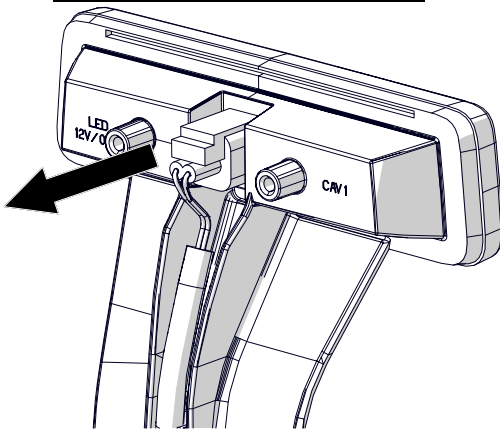

5

Remove tire mount

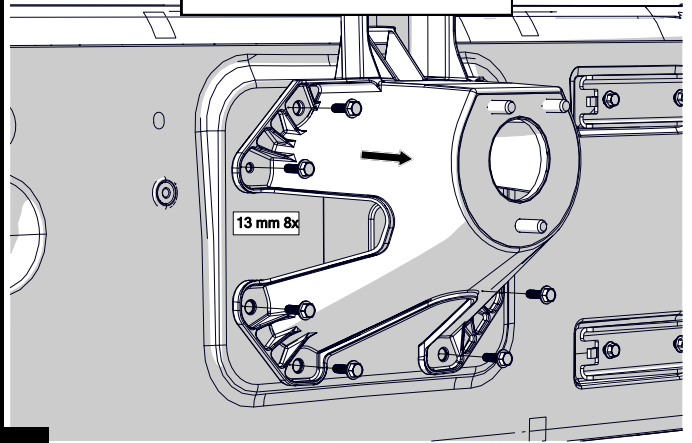

6

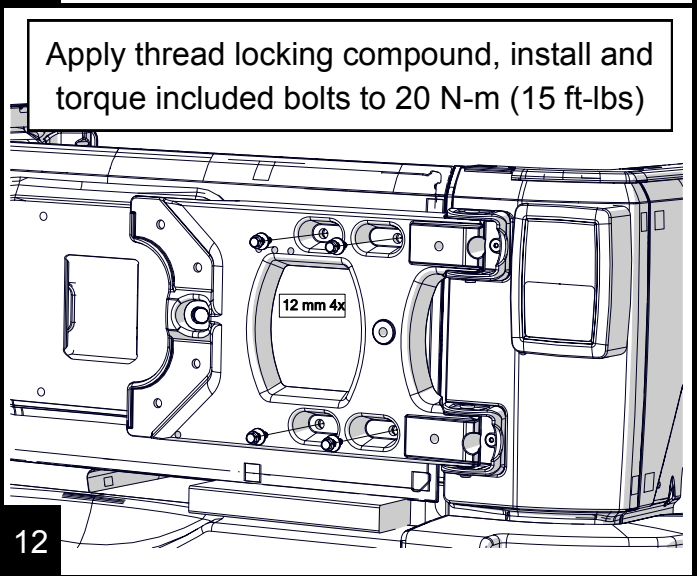
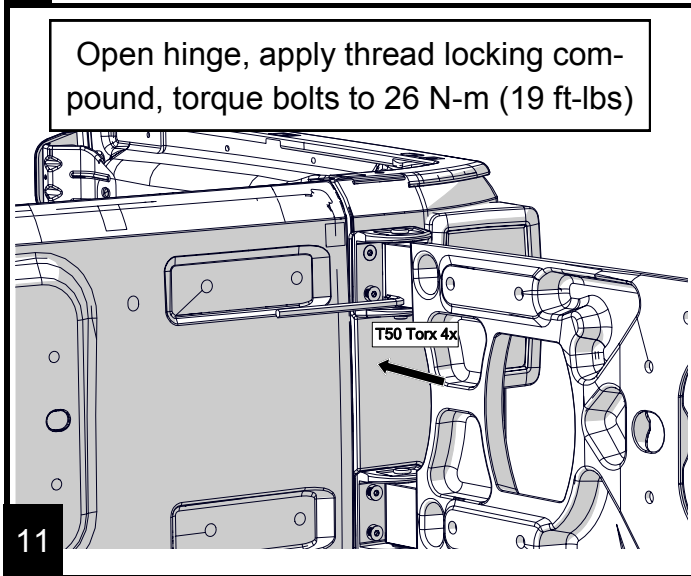
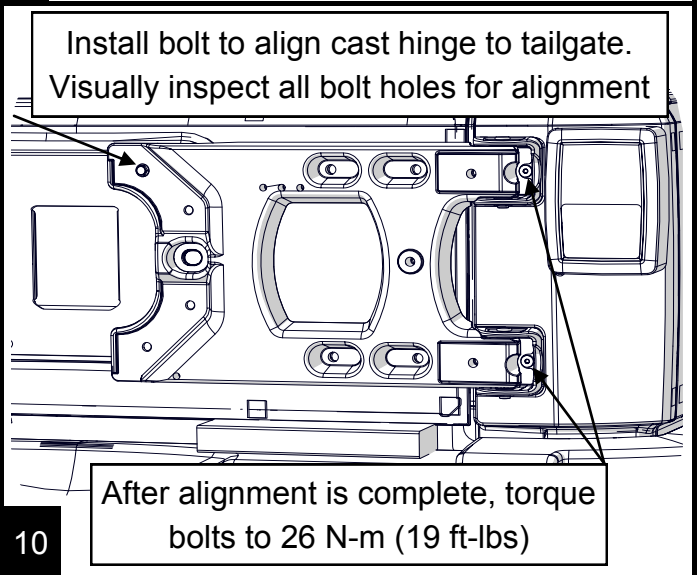
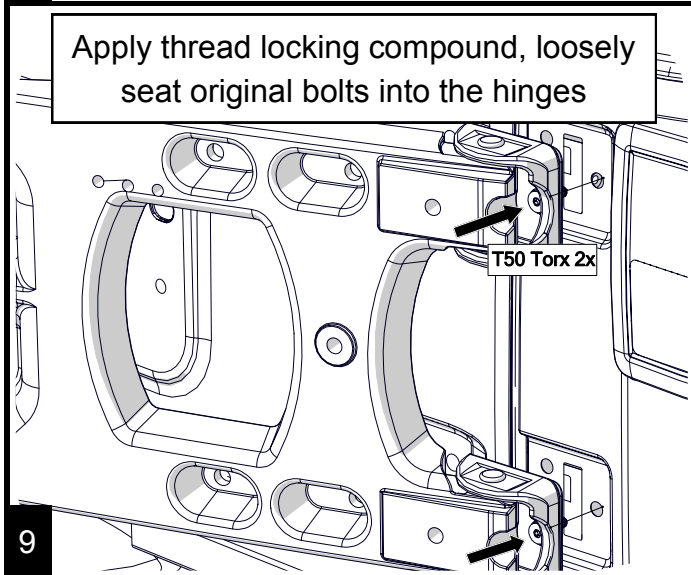
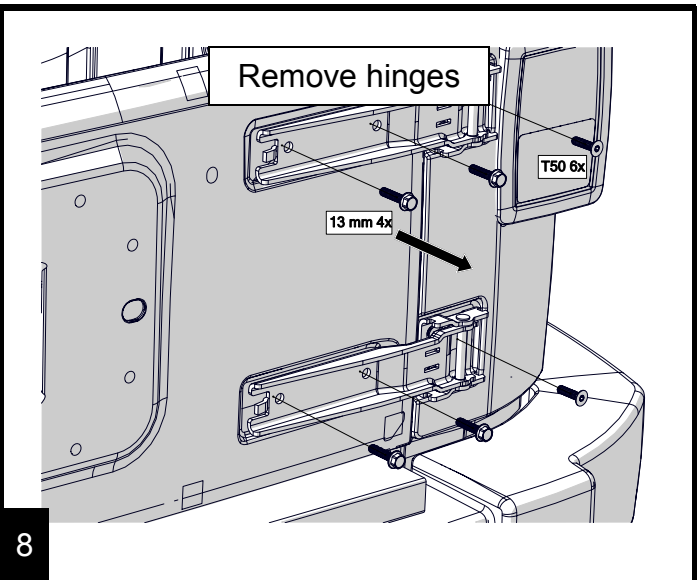
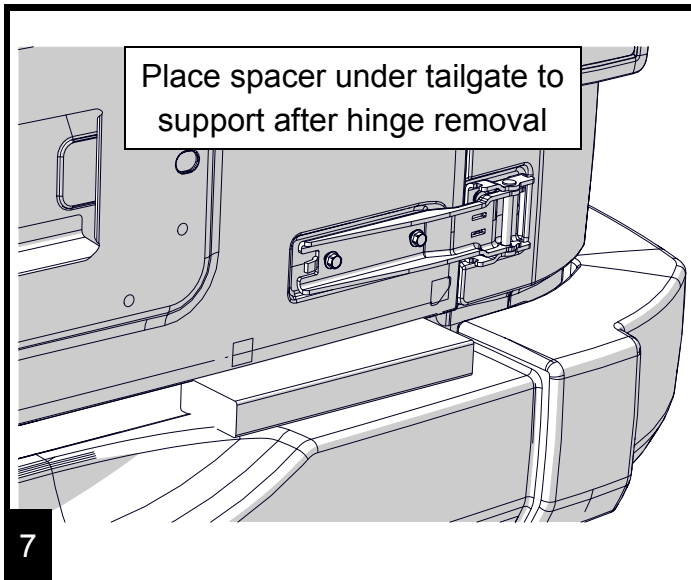

If installing the optional tire mount #77072345 in conjunction with cast hinge reinforcement kit, refer to instruction set K6862213 included with that kit. If reusing the factory tire mount, continue with step 14 in this instruction set.

13

Reuse original hardware, apply thread locking compound and loosely install bolts

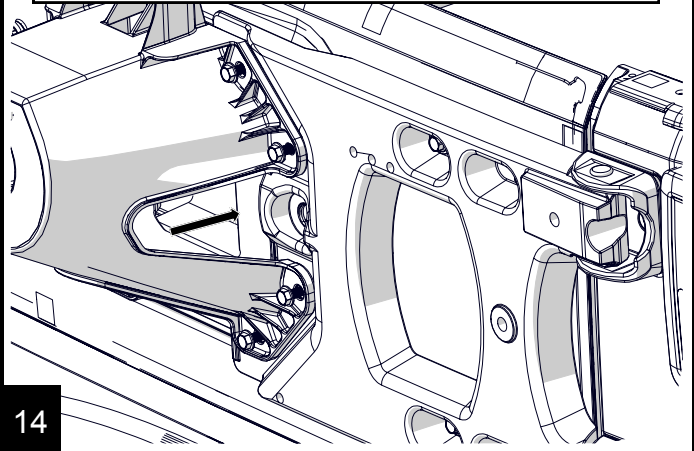

14

Orient spacers as illustrated

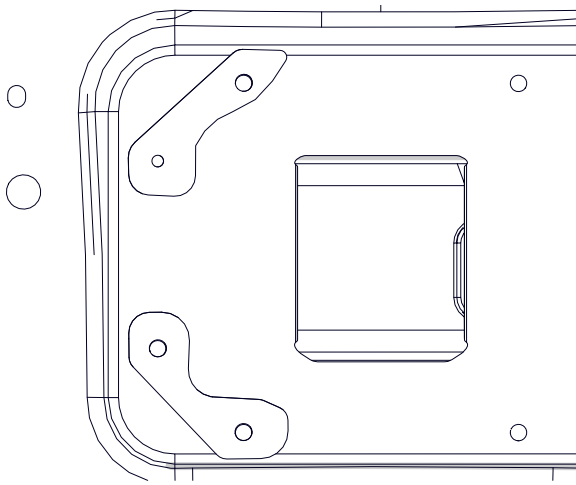

15

Note location of spacers, place gasket between spacer and tailgate. Apply thread locking compound and install bolts

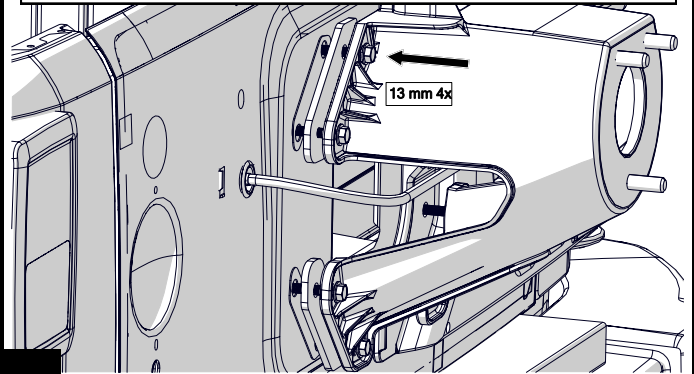

16

Torque 8 tire mount bolts to 20 N-m (15 ft-lbs)
Remove support spacer under tailgate

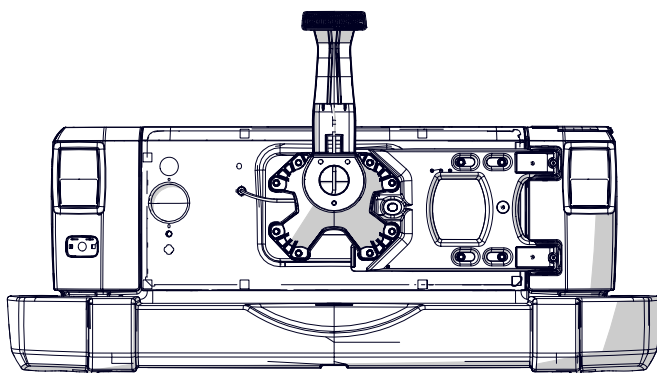

17

- Open and close tailgate to ensure proper function.
- Fold and place this instruction sheet in the vehicle glove box for future reference.
- For customer service questions, refer to your local Jeep dealership.

18



EQUIPO DE REFUERZO DE BISAGRA Y PUERTA TRACERA (ALUMINIO FUNDIDO)

www.mopar.com

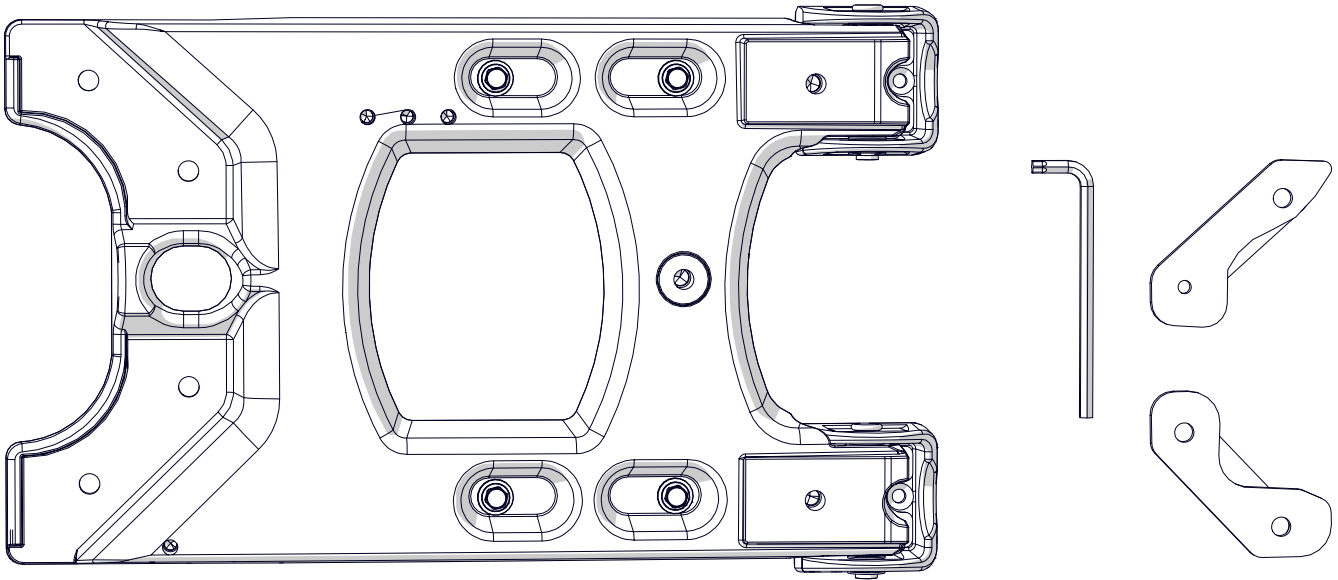

Notas Importantes:

Antes de comenzar ésta instalación, leer las instrucciones para acostumbrarse con los pasos necesarios, y para saber si usted es capaz de hacer las modificaciones . El manual de la fábrica se debe usar al lado de éstas instrucciones de instalación.

Referirse a la lista de piezas para asegurar que todos los componentes necesarios y refacciones estan incluido. Si le falta algo, hacer contacto con el concesionario local de Jeep para recibir ayuda.

Herramientas Necesarias:

- Llave de tuercas
- Llave de T50 Torx (incluido)
- Llave de T20 Torx
- Encaje de 13 mm
- Encaje de 12 mm
- Un torquete
- El sellador para tornillo (azul)
- Un espaciador que quepa entre el parachoque del Jeep y el fondo del portón. (Material blando, por ejemplo madera, esta recomendado para no dañar la pintura del vehículo)

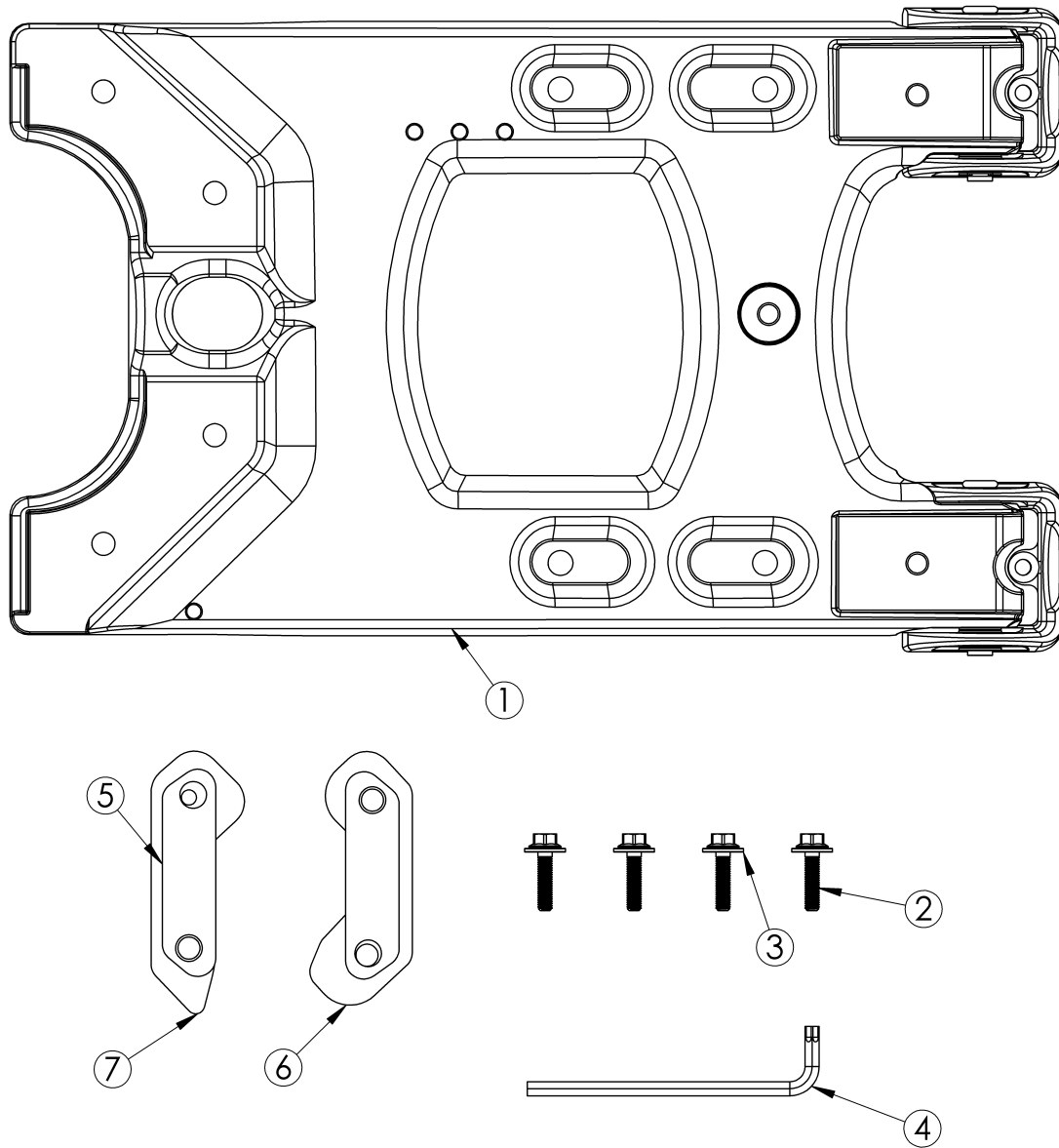

Número	Descripción	Cantidad	Número de parte
1	El montaje de goma con bisagras(aluminio fundido)	1	838175
2	M8 x 1.25 P x 35 mm tornillo del grado 10.9	4	209
3	M8 rondana plana	4	23
4	La llave de T50 Torx	1	387
5	El gásqet para los espaciadores	2	610039
6	El espaciador superior (arriba)	1	838104
7	El espaciador inferior (abajo)	1	838105

IMPORTANTE: No quitar las bisagras de la puerta trancera de la fábrica hasta que se reciba el mandato de hacerlo. El seguir con exactitud éstas instrucciones le ayudará evitar cualquier problema de mal ajuste y desalineación la puerta. Asegurarse que la puerta esta cerrada apretadamente. No abrirla mientras la instalación.

1

2



3



4

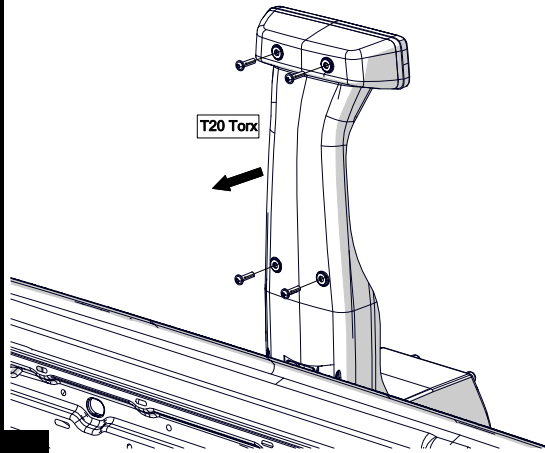

Desconectar el conector

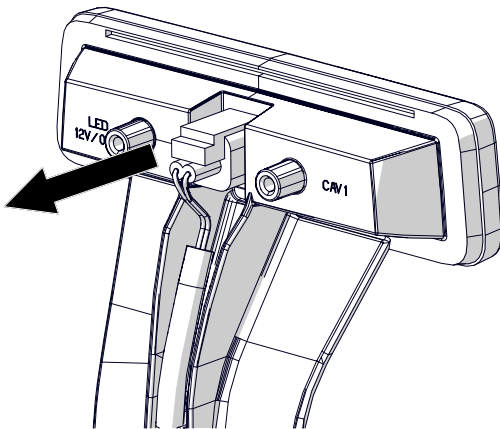

5

Quitar el montaje de goma

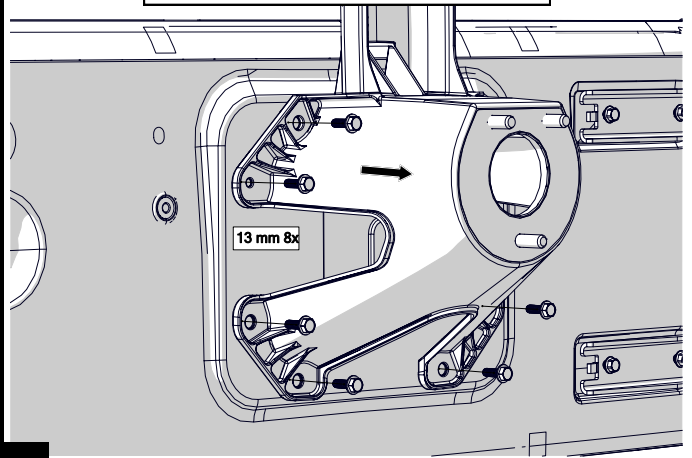

6

Poner el espaciador abajo de la puerta para poder apoyarla después de la eliminación de las bisagras.

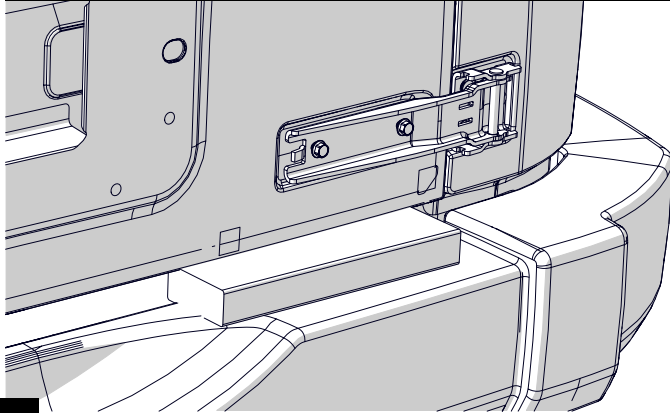

7

Quitar las bisagras

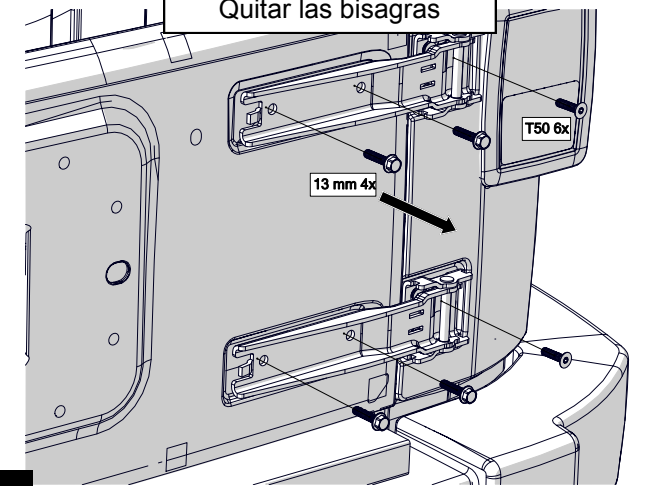

8

Aplicar sellador de tornillo(azul), flojamente apretar los tornillos originales a las bisagras.

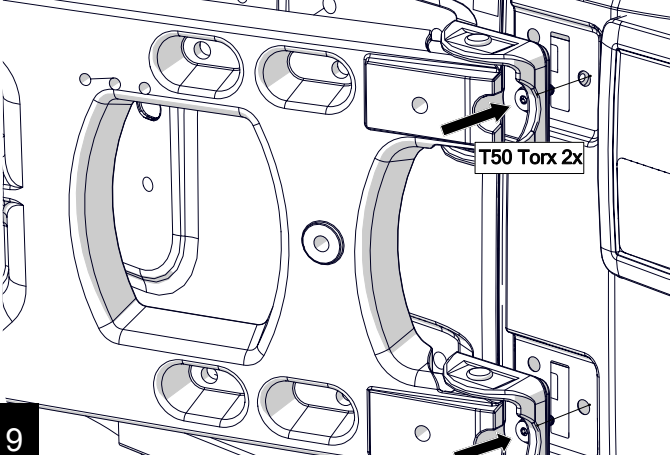

9

Instalar el tornillo para alinear la bisagra de aluminio fundido. Inspeccionar visualmente cada ahoyo de tornillo para alineación.

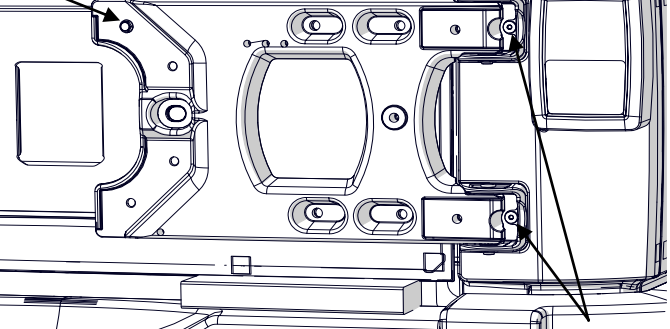

10

Después del alineamiento, apretar los tornillos a 26 N-m (19 ft-lbs)

Abrir la bisagra, aplicar sellador (azul), apretar los tornillos a 26 N-m (19 ft-lbs)

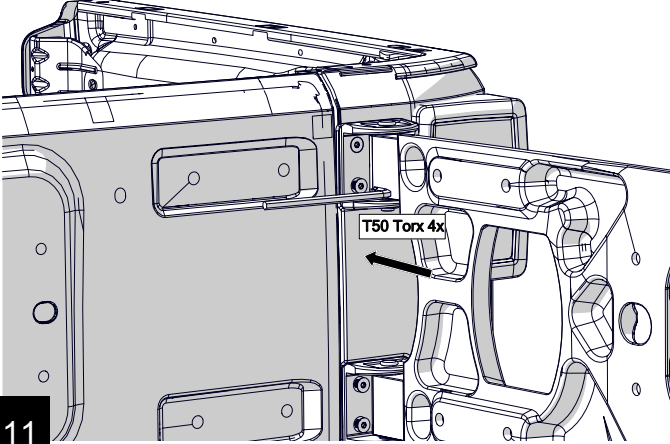

11

Aplicar sellador(azul), instalar y apretar los tornillos incluidos a 20 N-m (15 ft-lbs)

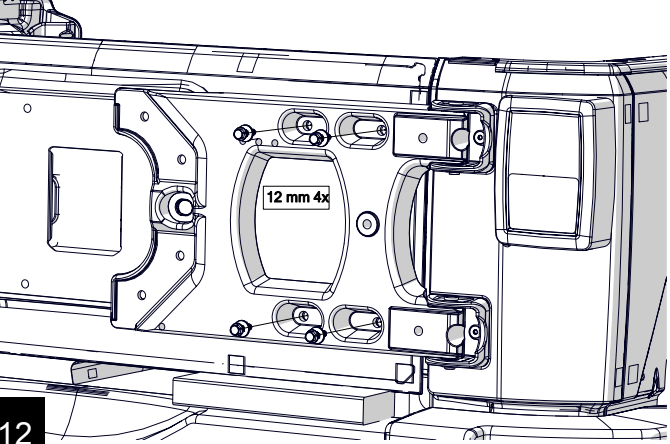

12

Si va a instalar el montaje de goma (opcional) #77072345 conjunto con este equipo, referirse al juego de instrucciones K6862213 que esta incluido con aquél juego. Si va a utilizar de nuevo el montaje de goma original, continuar con el paso numero 14 de este juego de instrucciones.

13

Utilizar de nuevo el hardware original. Aplicar sellador (azul) y flojamente apretar los tornillos.

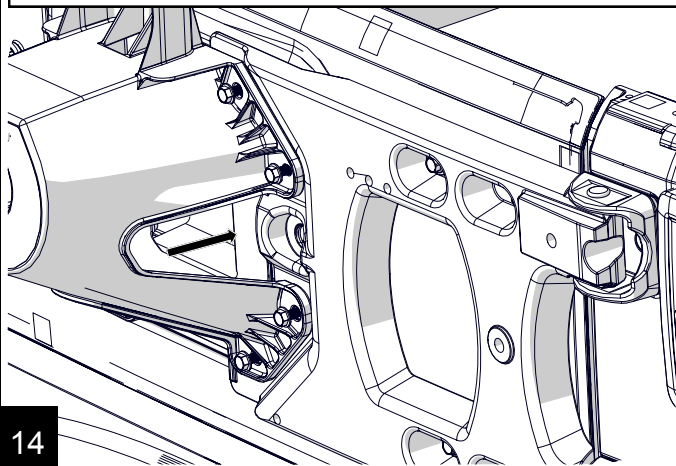

14

Posicionar los espaciadores de esta manera.

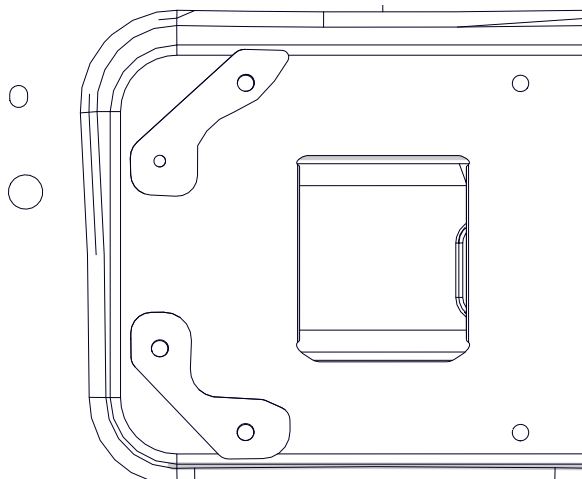

15

Darse cuenta de la locación de los espaciadores. Poner el gáseto entre el espaciador y la puerta. Aplicar sellador (azul) e instalar los tornillos.

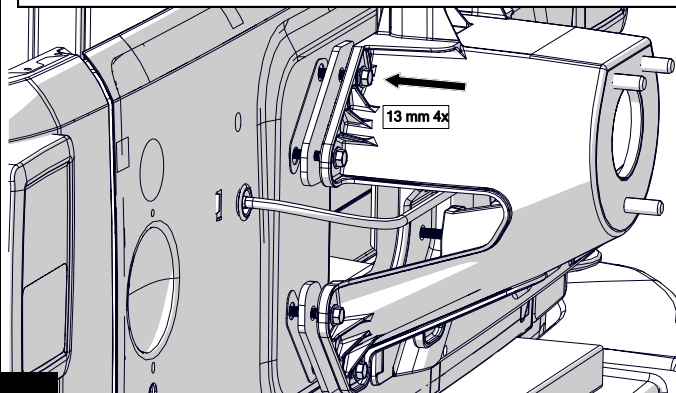

16

Apretar los 8 tornillos del montaje de goma a 20 N-m (15 ft-lbs)
Quitar el apoyo debajo de la puerta.

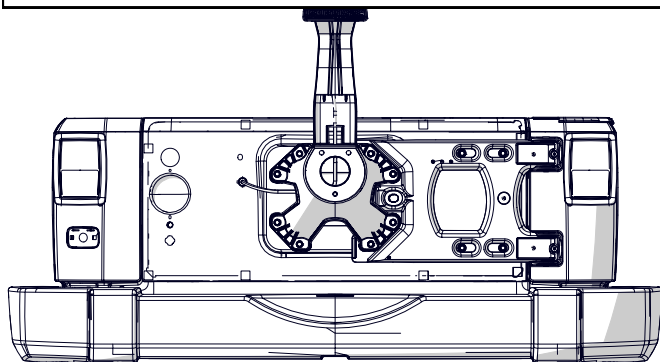

17

- Abrir y cerrar la puerta trasera para asegurar que funciona correctamente.
- Doblar y poner este juego de instrucciones en la consola del Jeep para futuras consultas.
- Si tiene preguntas, contactar el concesionario local de Jeep.

18



KIT DE RENFORT POUR HAYON ARTICULÉ

www.mopar.com

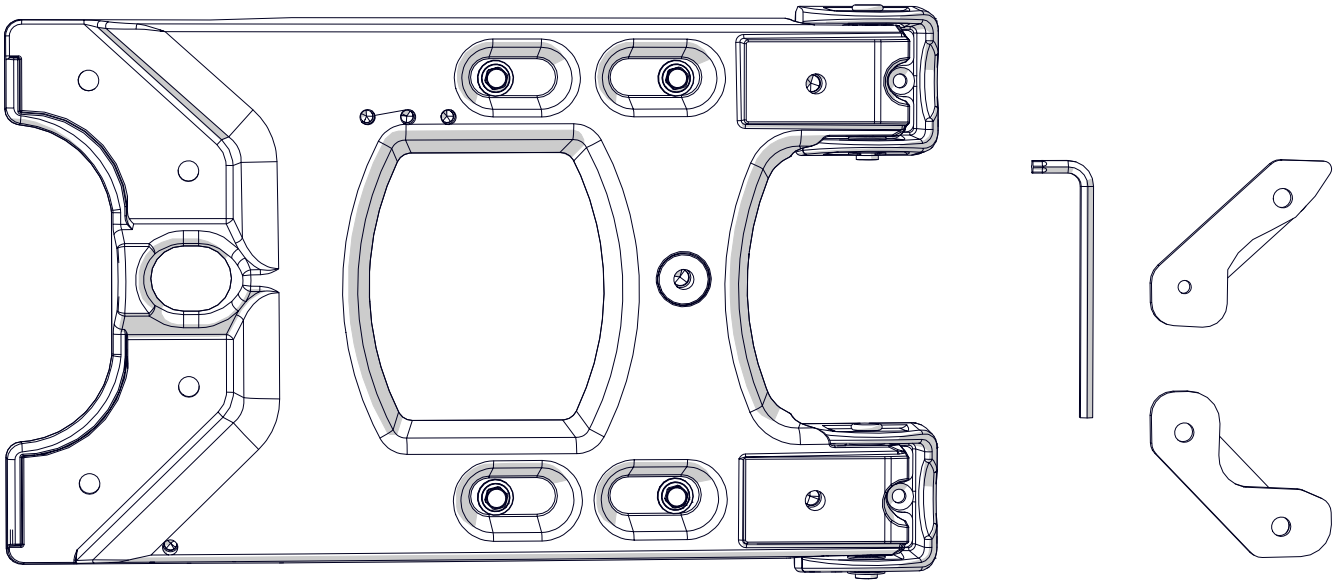

Remarques Importantes:

Avant de commencer cette installation, ou toute autre installation, veuillez lire ces instructions afin de vous familiariser avec les étapes nécessaires et d'évaluer si vous êtes expérimenté et capable d'effectuer personnellement ces modifications. Un manuel d'entretien du fabricant devrait être utilisé en conjonction avec ces instructions d'installation.

Référez-vous à la liste des pièces pour vous assurer que tous les composants et le matériel nécessaires ont été inclus. Si des pièces sont manquantes, s'il vous plaît contactez votre concessionnaire Jeep local pour assistance.

Outils nécessaires:

- Clé à écrou
- Clé Torx T50 (inclue)
- Clé Torx T20
- Douille 13 mm
- Douille 12 mm
- Cliquet
- Scellant à filets bleu
- Bloc qui prendra place entre le pare-chocs de votre Jeep et le bas du hayon articulé (un matériel souple tel que le bois est recommandé pour éviter d'endommager la peinture du véhicule)

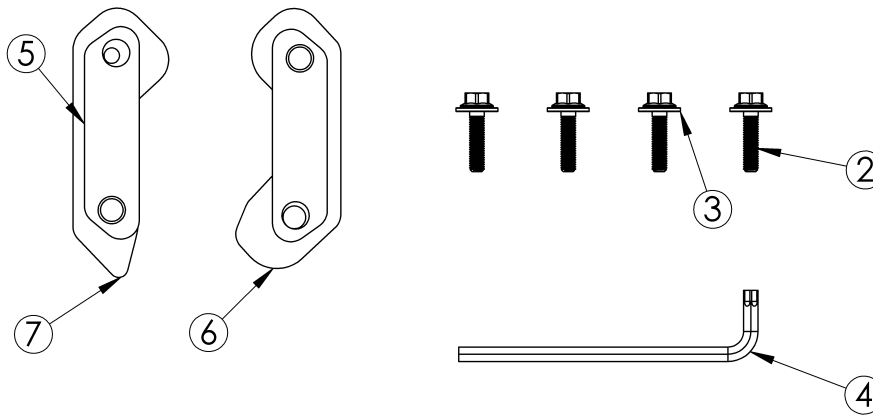
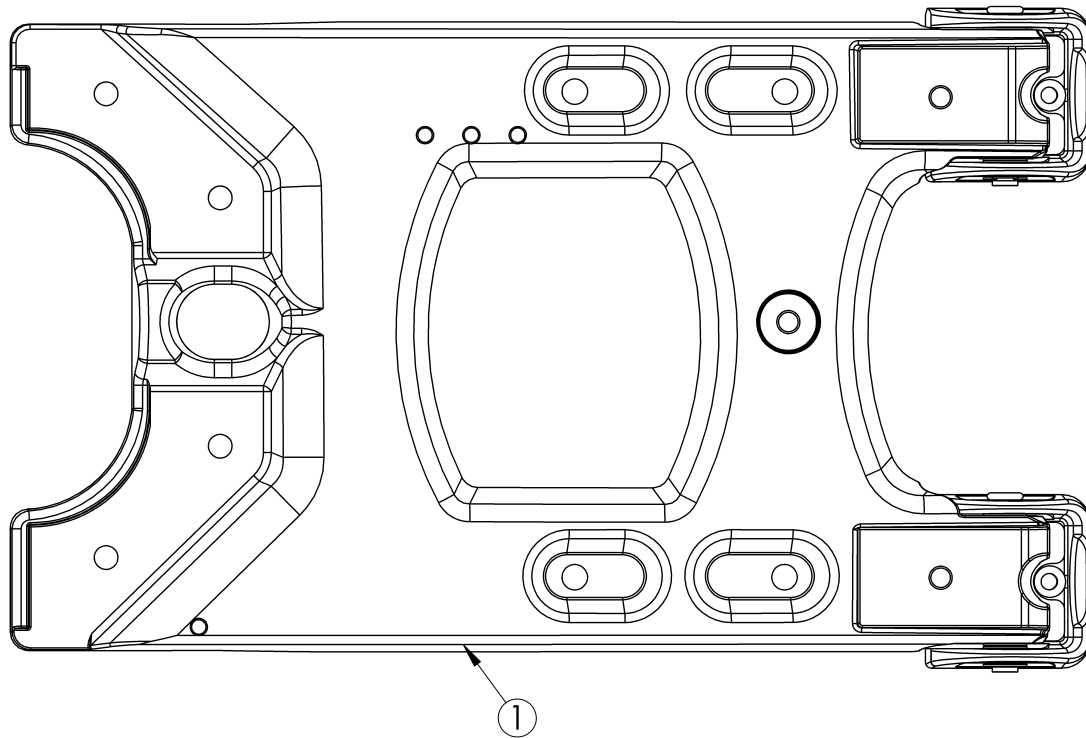

Identification	Description	Quantité	Numéro de pièce
1	Support de pneu de JK en aluminium	1	838175
2	Long boulon M8 x 1.25 P x 35mm classe 10.9	4	209
3	Rondelle plate M8	4	23
4	Clé Torx T50	1	387
5	Joint de plaque entretoise	2	610039
6	Plaque entretoise inférieure	1	838104
7	Plaque entretoise supérieure	1	838105

IMPORTANT: Ne retirez pas les charnières du hayon articulé d'origine tant que vous n'êtes pas rendu à cette étape du plan. En suivant ces instructions précisément, vous éviterez les problèmes d'alignement et d'ajustement du hayon. Assurez-vous que le hayon articulé est bien fermé pendant l'installation. Ne l'ouvrez pas.

1

2



3



4

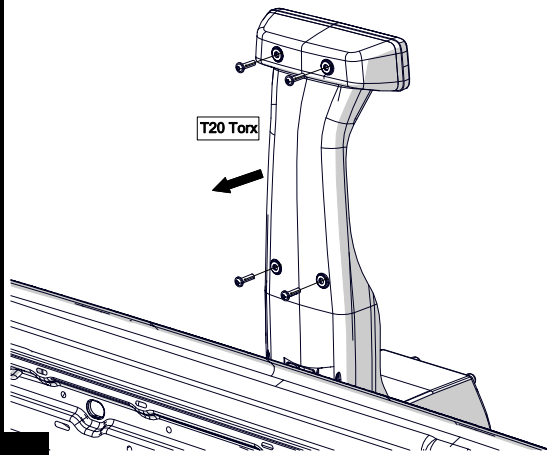

Débranchez le connecteur de lumière

Retirez le support du pneu

5

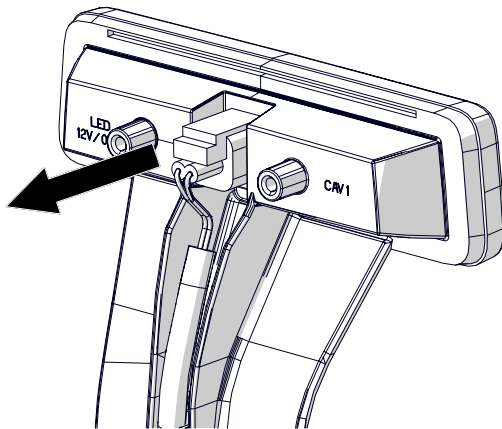

6

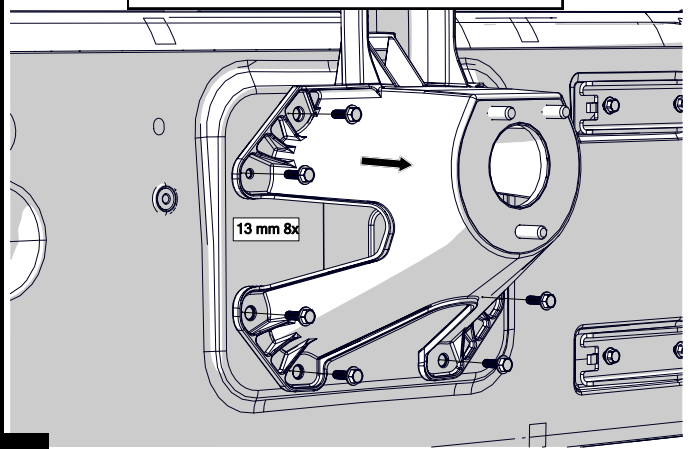

Placez le bloc sous le hayon articulé afin de le supporter suite au retrait des charnières

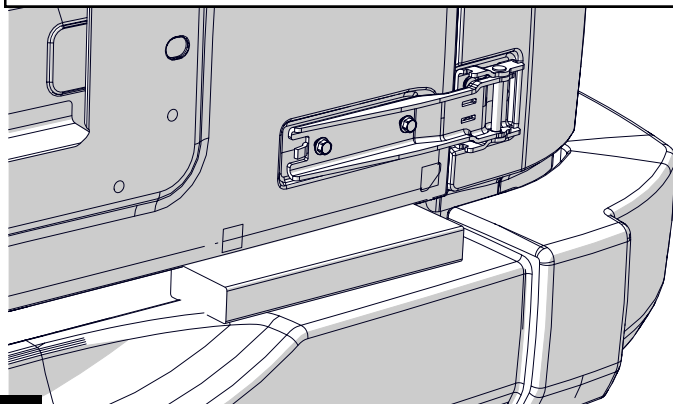

7

Retirez les charnières

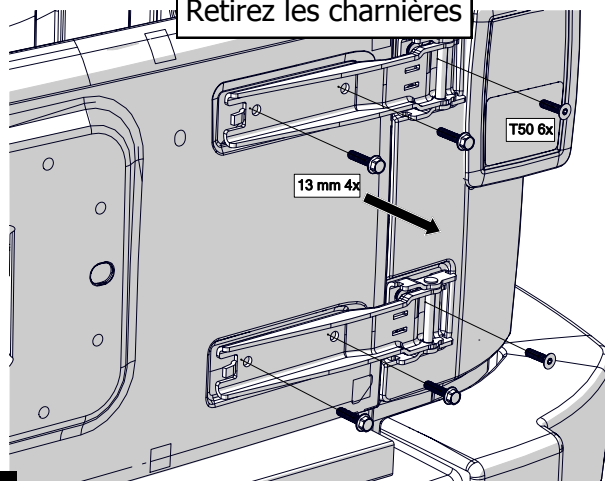

8

Appliquez le scellant à filets et placez les boulons d'origine dans les charnières, sans les serrer

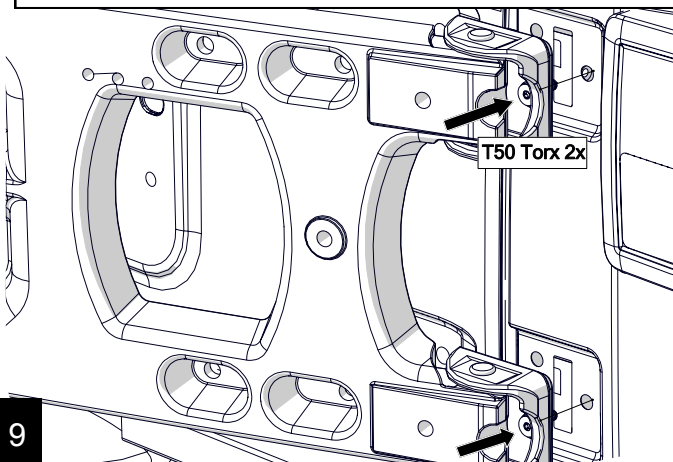

9

Installez un boulon afin d'aligner le kit de renfort au hayon. Inspectez visuellement tous les trous de boulons afin d'en assurer l'alignement

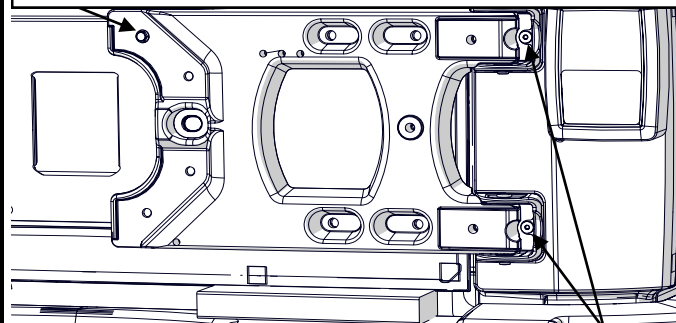

10

Suite à l'alignement, serrez tous les boulons à 26 N-m (19 ft-lbs / pied-livre)

Ouvrez la charnière, appliquez du scellant à filets et serrez les boulons à 26 N-m (19 ft-lbs / pied-livre)

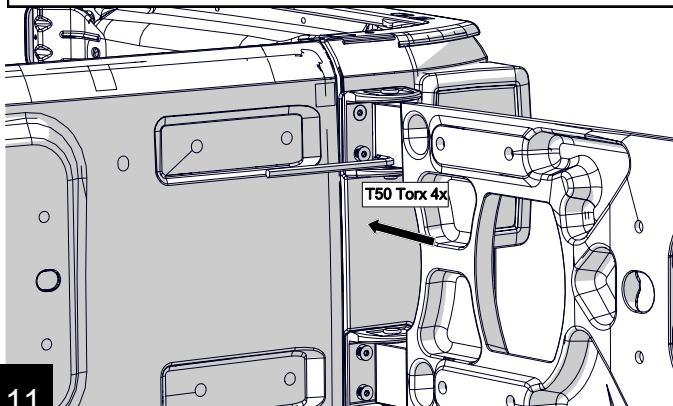

11

Appliquez du scellant à filets et serrez les boulons à 20 N-m (15 ft-lbs / pied-livre)

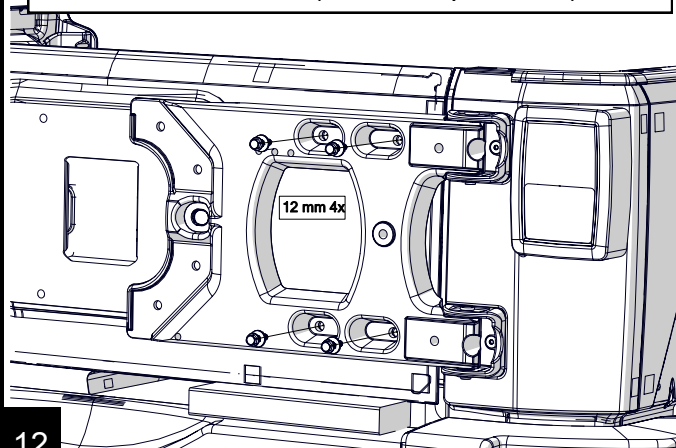

12

Si vous installez le support de pneu optionnel # 77072345 en conjonction avec cet ensemble de renfort pour charnière, référez-vous aux instructions K6862213 incluses avec cet ensemble. En cas de réutilisation du support d'origine, passez à l'étape 14 des présentes instructions.

13

Réutilisez le matériel d'origine, appliquez le scellant à filets et placez les boulons, sans les serrer.

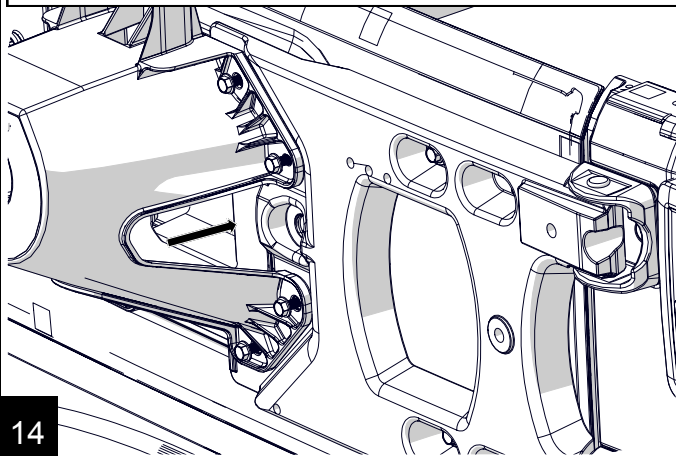

14

Orientez les entretoises comme illustré

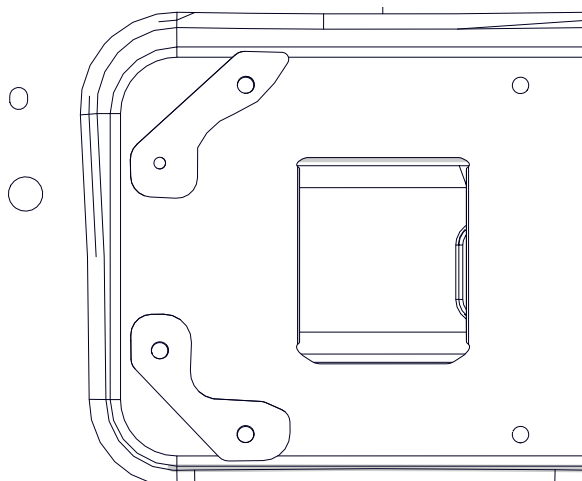

15

Remarquez l'emplacement des entretoises, placez le joint entre l'entretoise et le hayon articulé. Appliquez le scellant à filets et installez les boulons

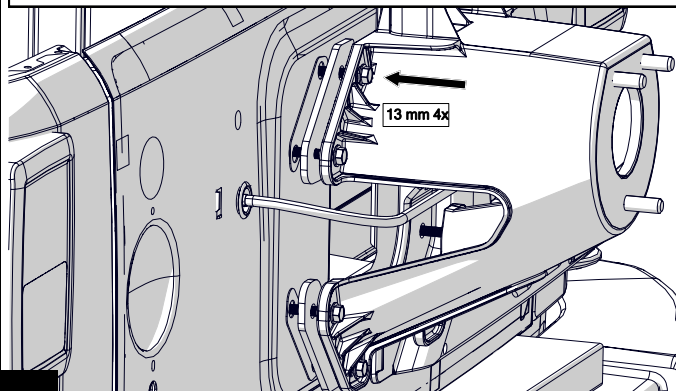

16

Serrez les 8 boulons du support de pneu à 20 N·m (15 ft-lbs / pied-livre)
Retirez le boc sous le hayon articulé

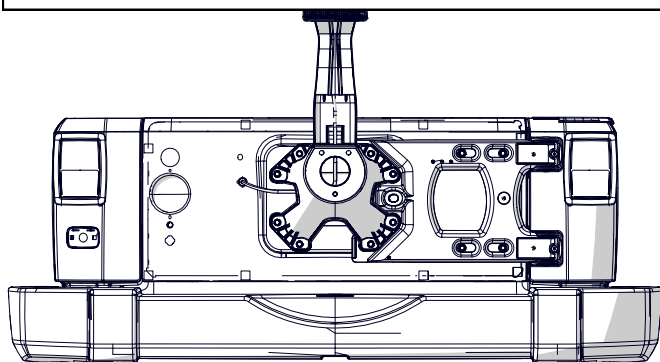

17

- Ouvrez et fermez le hayon articulé afin d'en assurer le bon fonctionnement.
- Pliez et placez ce feuillet d'instructions dans la boîte à gants du véhicule pour référence future.
- Pour des questions de service à la clientèle, référez-vous à votre concessionnaire Jeep local.

18