



# BED EXTENDER 2005 ⇒ DODGE DAKOTA

## INSTALLATION INSTRUCTIONS

*Read entire instructions thoroughly before starting.*

### TOOLS REQUIRED:

- Utility knife
- Tape measure
- Soapy water
- Clean rag
- Rubber mallet
- T20, T40 Torx driver
- Torque Wrench
- Chalk
- Black or white grease pencil
- 1/8", 5/32" drill bits
- 1" hole saw
- Drill motor
- Round file/sandpaper
- Shop Vacuum

### CONTENTS:

Item	Qty.	Description
①	2	Left/Right Mounting Brackets
②	1	Right Tube Section
③	1	Left Tube Section
④	3	Center Tubes
⑤	6	Inner Stanchion Wedges
⑥	6	Outer Stanchion Wedges
⑦	6	Stanchion Adjustment Screws
⑧	2	Retention Brackets
⑨	4	Bi-Wax Screws
⑩	1	Instruction Sheet

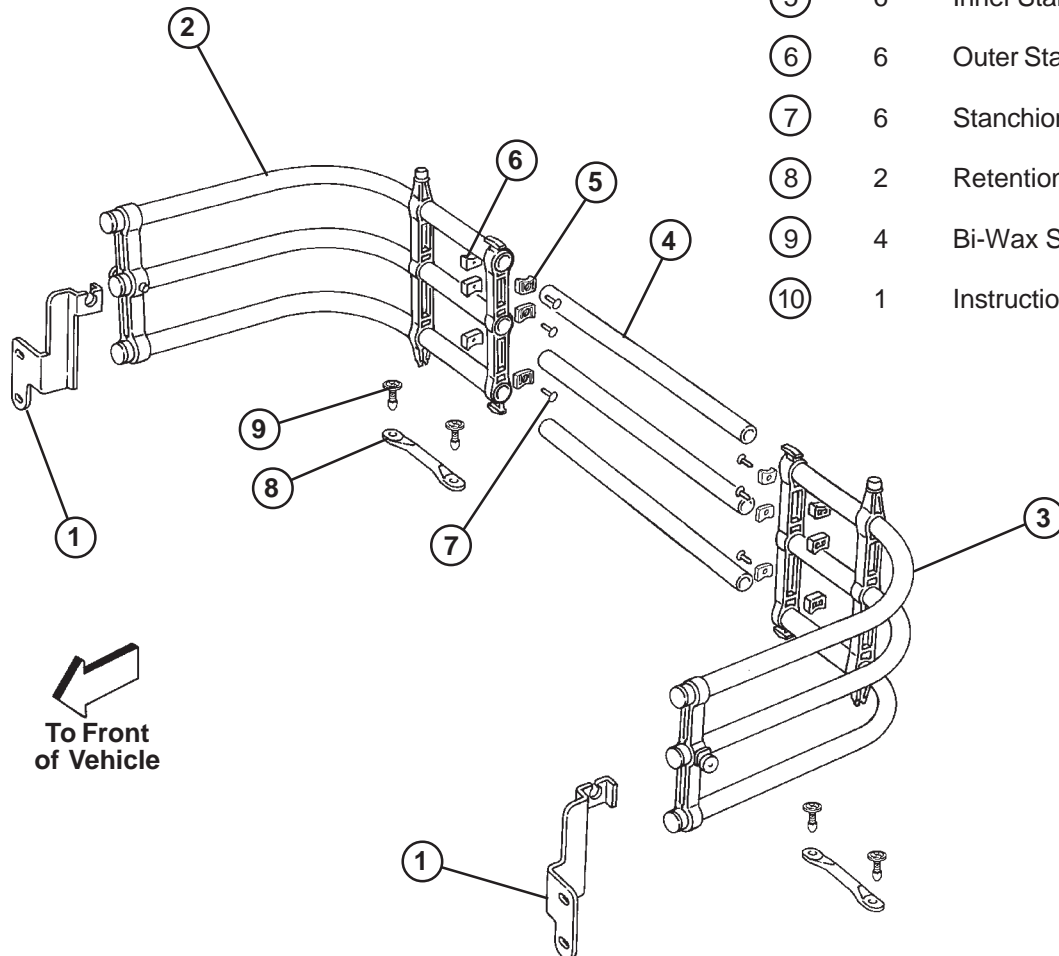

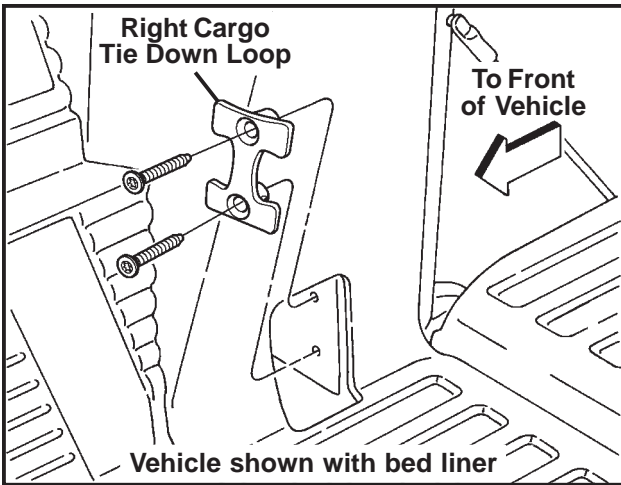

**A – Install Mounting Brackets:**

- 1) Using a T40 torx driver, remove screws attaching the cargo tie down loops to the vehicle.
- 2) Install right and left mounting brackets (Item 1) with existing screws as shown.

**Hints for vehicles equipped with bed liner:**

- Push tie down loop into bed liner cut-out to allow access of socket wrench.
  - Finger start bottom screw first, then top screw.
- 3) Tighten screws to 300 in.-lbs. (34 N·m).

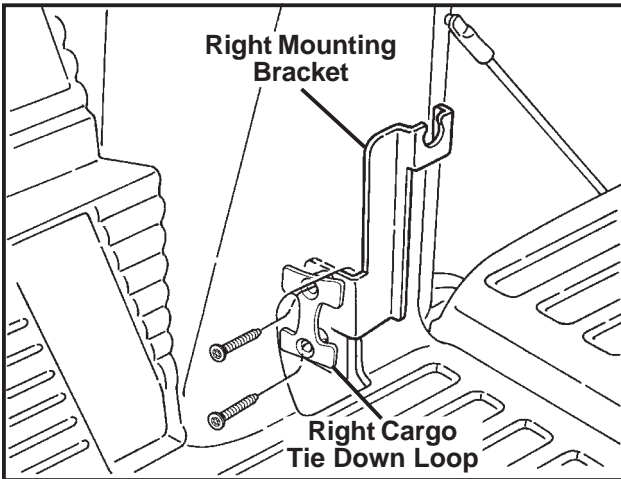

**B – Assemble and install Bed Extender:**

- 1) Loosely join the right tube section (Item 2), then the left tube section (Item 3) to the center tubes (Item 4) as shown.

**NOTE:**

*The center tubes have a smaller diameter than the left and right outer tube diameters. Slide center tubes into the outer tubes per Step B2.*

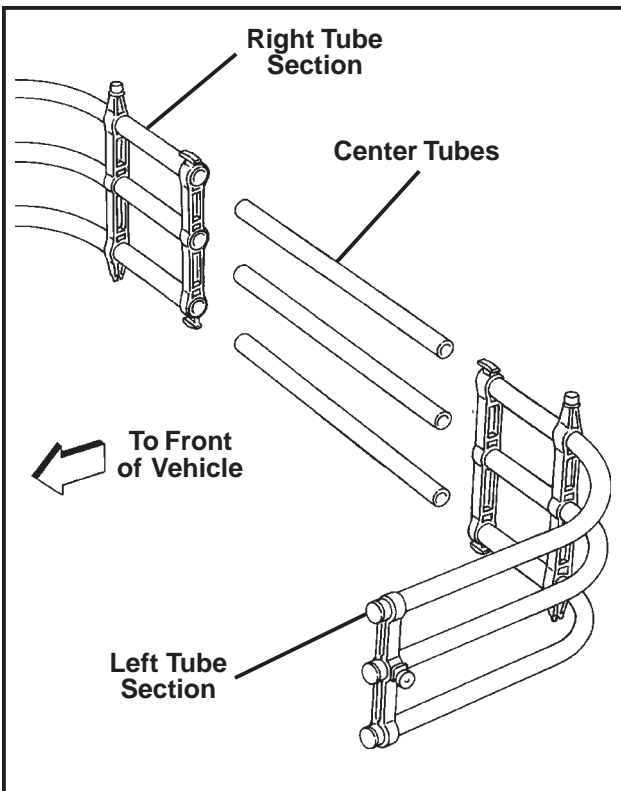

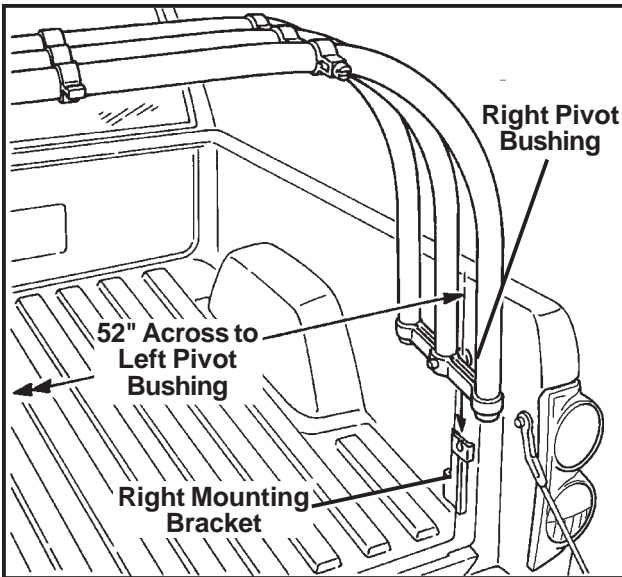

- 2) Lubricate with soapy water and adjust the bed extender assembly width to 52" (132.2mm).
- 3) Drop assembly down vertically into the mounting brackets as shown. (Make sure that the two slotted feet are pointed rearwards).

**NOTE:**

*Due to the unique locking provision of the Bed Extender, the only way it may be installed or removed is the vertical insertion into the mounting brackets.*

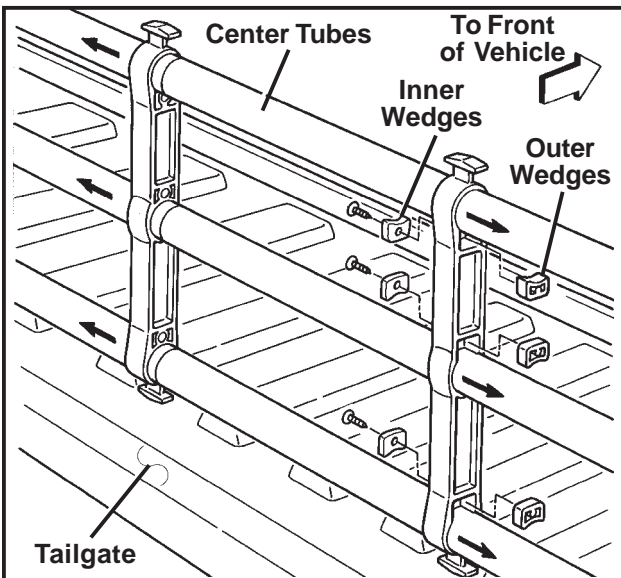

**C – Positioning of center tubes stanchions:**

- 1) Rotate assembly onto the open tailgate.
- 2) One side only, insert six wedges (Items 5 and 6) into wedge pockets in stanchion.
- 3) Insert three stanchion adjustment screws (Item 7).
- 4) Using a T20 torx driver, tighten the screws after the stanchion is securely in place.
- 5) Repeat procedure on the other center stanchion.

**VEHICLES EQUIPPED WITH BED LINER**

*Vehicles without bed liner-skip to section F on page 5.*

**D – Positioning of bed extender assembly to bed liner:**

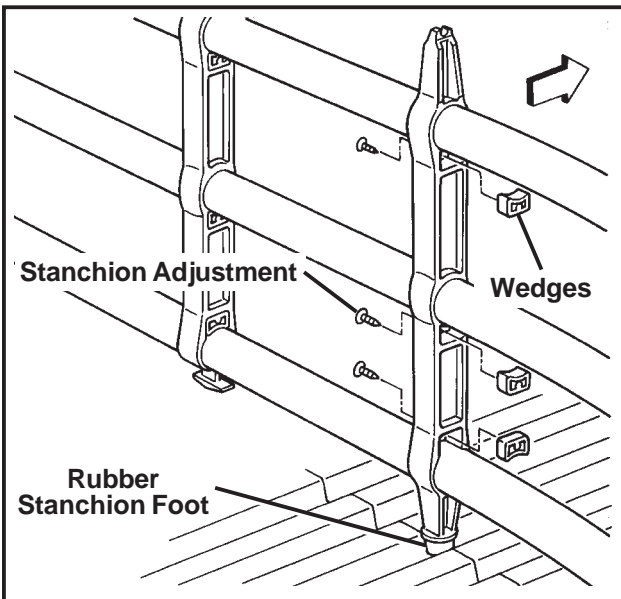

- 1) Rotate assembly onto the bed liner. (The stanchion feet should set in a recess of the bed liner ribs.)
- 2) If adjustment is necessary, loosen three adjustment screws from stanchion on the right tube section and remove locking wedges.
- 3) Align the stanchion as shown. Re-install the wedges and screws.
- 4) Repeat procedure for stanchion on the left tube section, if necessary.

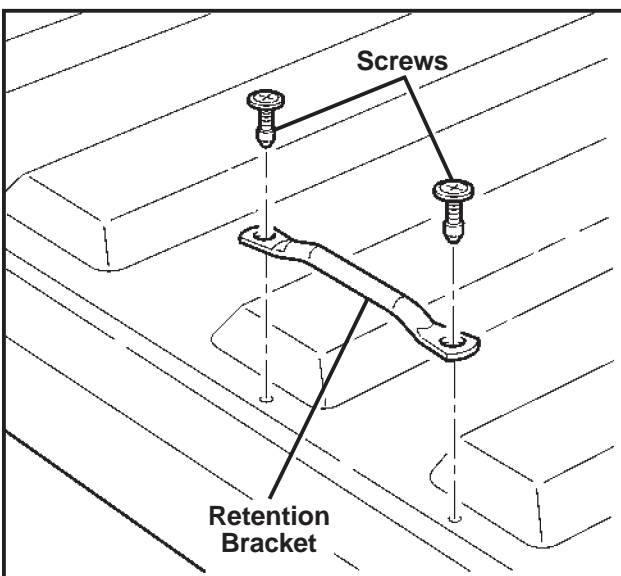
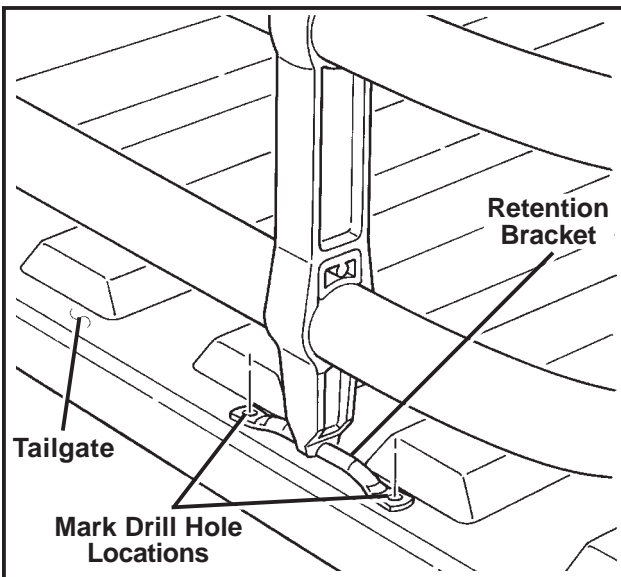
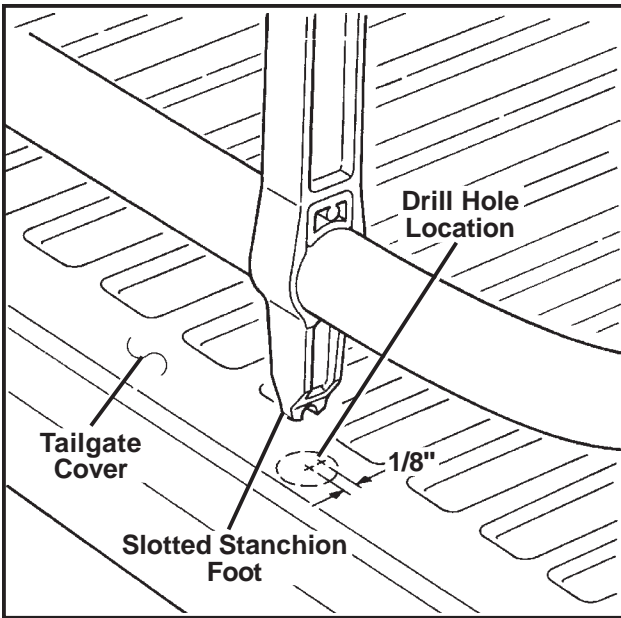

***E – Install retention brackets onto tailgate:***

- 1) Rotate assembly onto the tailgate cover. Using the slotted stanchion feet as a template, mark circumference of the feet to determine the center.
- 2) Rotate assembly into the truck bed.
- 3) Move center point 1/8" forward (towards the truck bed).
- 4) **Remove cover from the tailgate.** (Save the fasteners.)
- 5) Drill 1/8" pilot holes through the cover at the center points determined in Step 3.
- 6) Using a 1" hole saw, drill out the two stanchion feet access holes from the cover. (Smooth hole edges with a file or sandpaper).
- 7) Attach retention brackets (Item 8) to the slotted stanchion feet as shown.
- 8) Rotate assembly onto the tailgate. Using the bracket's mounting holes as a template, mark drill hole locations.
- 9) Drill 1/8" pilot holes through the tailgate panel at your marks.
- 10) Drill 5/32" mounting holes. Deburr the holes and vacuum up shavings.
- 11) Install supplied bi-wax screws (Item 9) through both retention brackets and into the tailgate. **Do not use power tools or overtighten. Tighten screws to 30 in.-lbs. (3 N·m).**
- 12) Re-install tailgate cover previously removed in Step 4. **Do not use power tools** on the mounting screws.

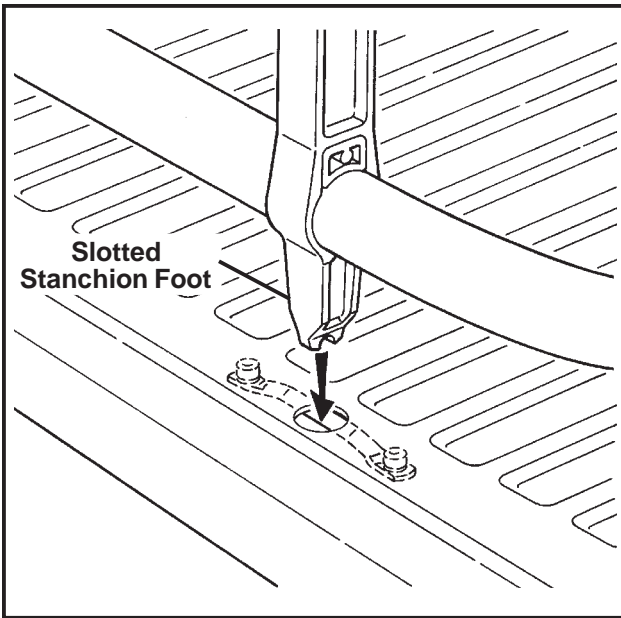

- 13) Push down on assembly until the slotted stanchion feet engage the retention brackets with two audible clicks.
- 14) Installation is now complete. Go to page 6 for verification procedures.

## VEHICLES WITHOUT BED LINER

### ***F – Positioning of bed extender assembly to truck bed:***

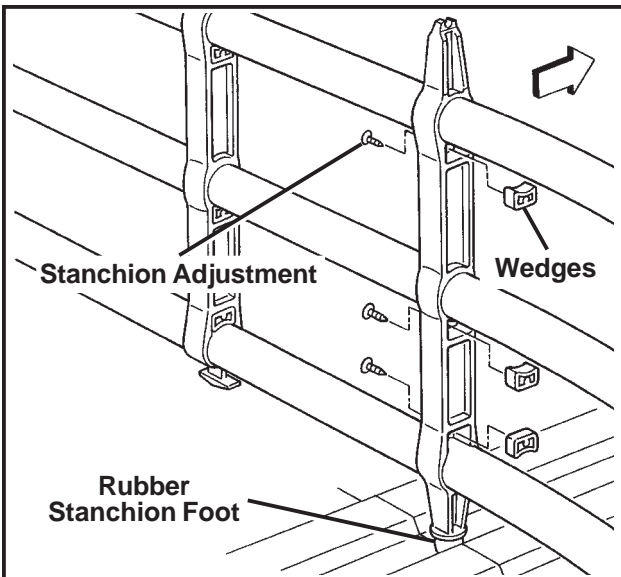

- 1) Rotate assembly onto the truck bed. (The stanchion feet should set in a recess of the bed ribs.)
- 2) If adjustment is necessary, loosen three adjustment screws from stanchion on the right tube section and remove locking wedges.
- 3) Align the stanchion as shown. Re-install the wedges and screws.
- 4) Repeat procedure for stanchion on the left tube section, if necessary.

### ***G – Install retention brackets onto tailgate:***

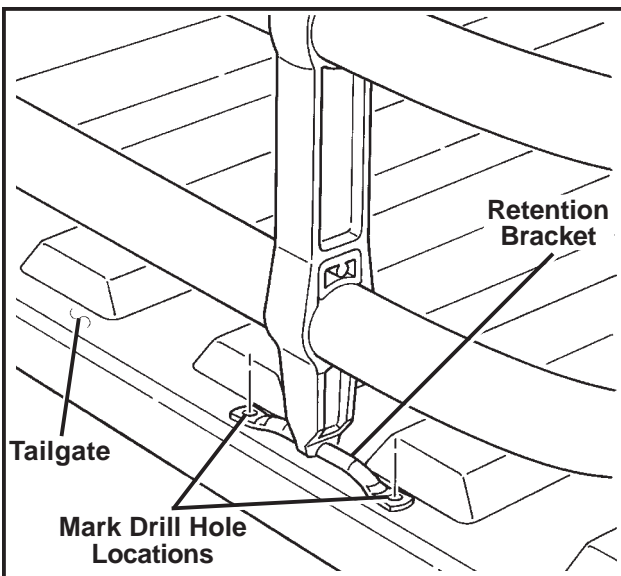

- 1) Rotate assembly onto the open tailgate. Attach retention brackets (Item 8) to the slotted stanchion feet as shown.
- 2) Using the bracket's mounting holes as a template, mark drill hole locations.
- 3) Drill 1/8" pilot holes through the tailgate inner panel at your marks.
- 4) Drill 5/32" mounting holes. Deburr the holes and vacuum up shavings.

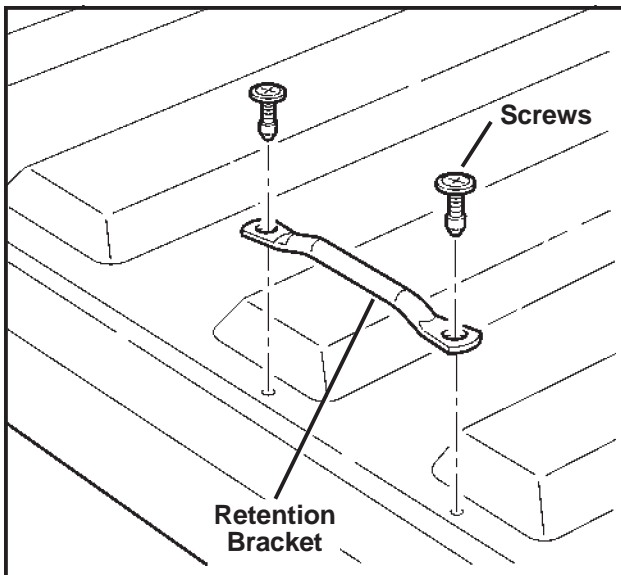

- 5) Install supplied bi-wax screws (Item 9) through both retention brackets and into the tailgate. **Do not use power tools or overtighten. Tighten screws to 30 in.-lbs. (3 N·m).**

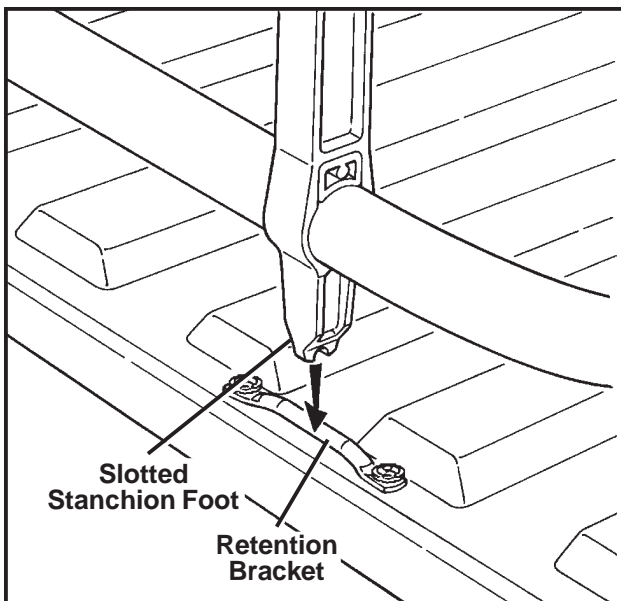

- 6) Push down on assembly until the slotted stanchion feet engage the retention brackets with two audible clicks.

***H – Verify Bed Extender Operation:***

***Vehicles with tailgate cover only:***

- 1) Rotate bed extender onto tailgate. Verify that the clearance holes in the tailgate cover are large enough to allow slotted feet to engage retention brackets. (Modify hole with file if necessary).

***All Applications:***

- 1) Raise bed extender to vertical position. Lift up on the unit vertically. It should easily be dislodged from the body brackets. Adjust bed extender width slightly, if necessary.
- 2) Re-install bed extender and rotate inboard and outboard.
- 3) Re-check all attaching screws and bolts in stanchions and bracketing.