

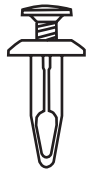

 <p>A X1 LH Bedrail Cap</p>	 <p>D X3</p>	 <p>E X4</p>
 <p>B X1 RH Bedrail Cap</p>	 <p>5/16" (8mm)</p>  <p>5/8" (16mm)</p> 	
 <p>C X1 Tailgate Cap</p>		
<p>1 Note: Without removal of tape backing, fit bedrail cap (step 6) and tailgate cap (step 9) to check for interface, trim bedliner etc. if necessary (step 2).</p>		
 <p>Dakota Only</p> <p>Ram Only</p> <p>1/4"</p> <p>2</p>	 <p>3</p> <p>4 Note: Ram Only if Desired Drill dimples in all stake pockets, cut with knife</p>	

Subject to alteration without notice
 Veränderungen vorbehalten
 Reservadas modificaciones técnicas
 Assujetti à des modifications sans préavis

Expert Fitment Required
 Fachmännische Einrichtung notwendig
 Montaje sólo por el concesionario
 Montage par spécialiste nécessaire

K6859370
 Aug-2004

© DAIMLERCHRYSLER

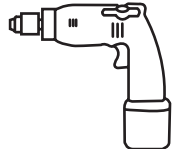
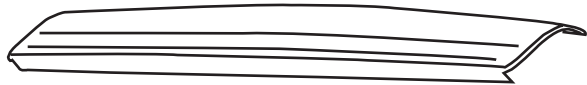
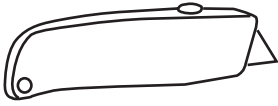
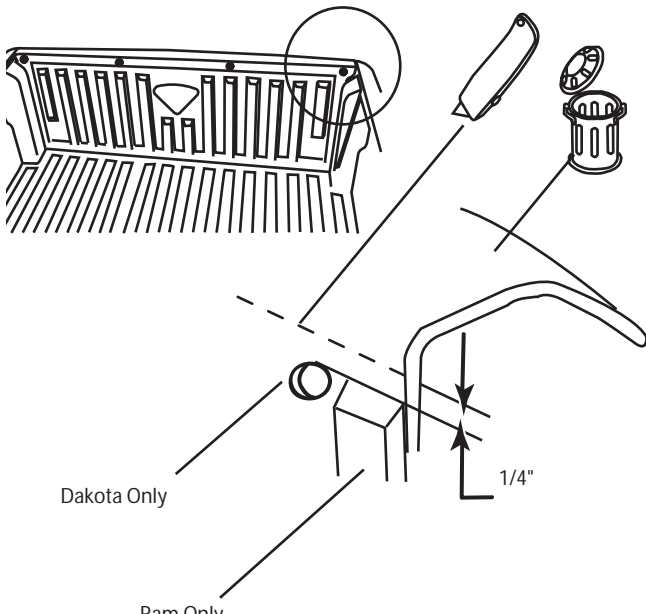
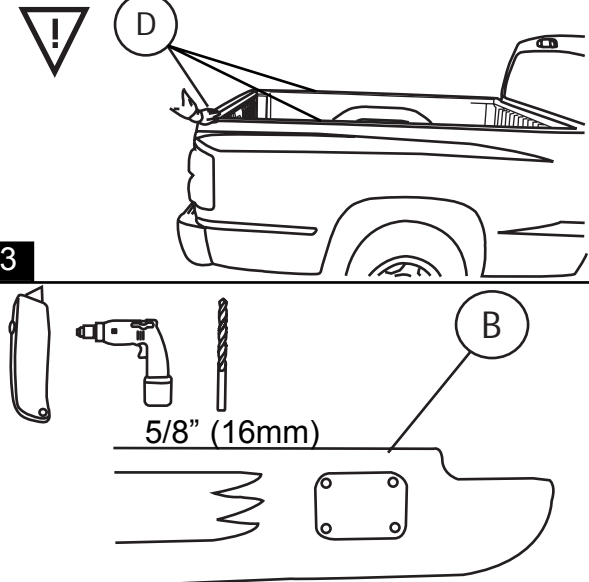
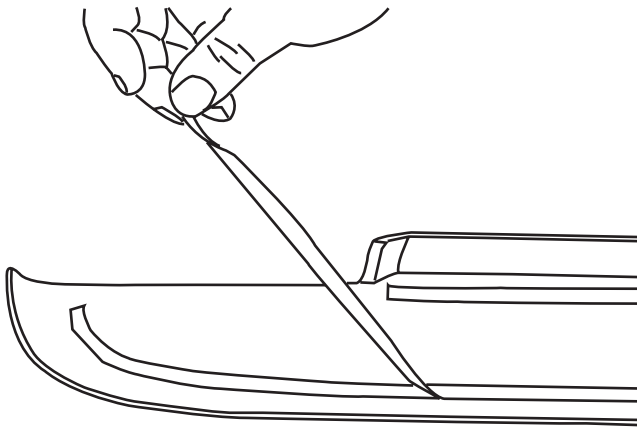

5

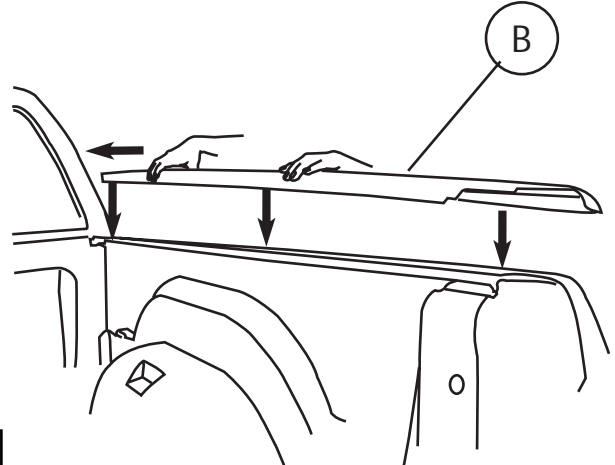

6

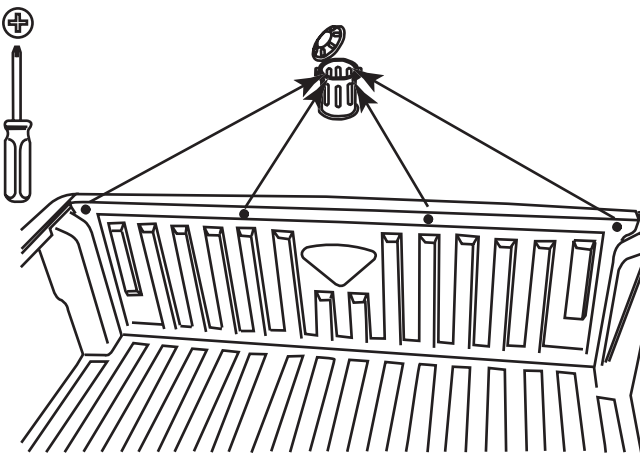

7

Note: For Dakota Only

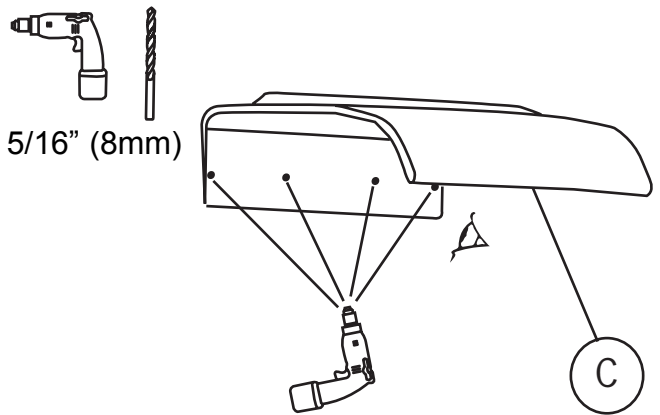

8

Note: For Dakota Only

Note: Remove tape backing from cap first.

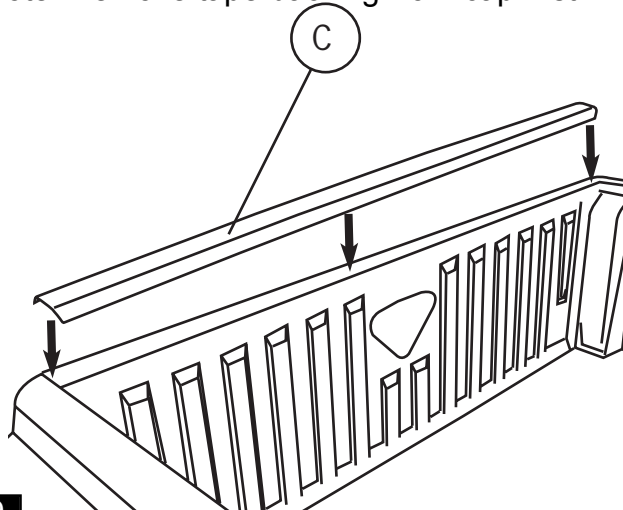

9

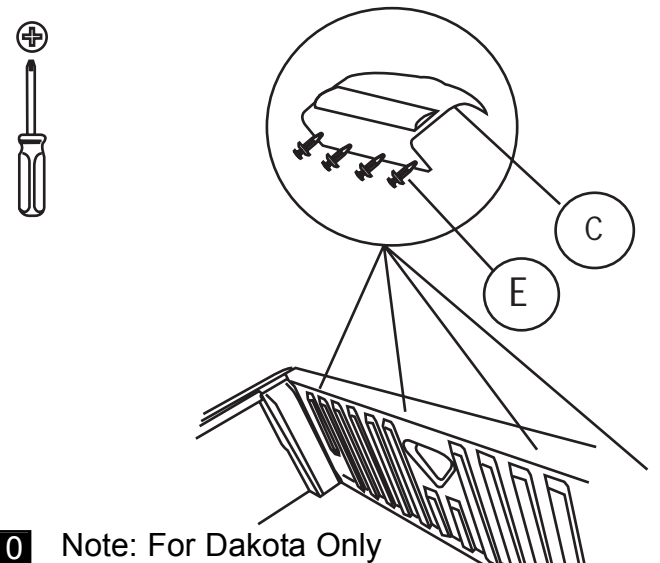

10

Note: For Dakota Only

GB NOTE: Repeat steps 2-5 on the driver side

F NOTE: Répétez les étapes 2-5 pour le côté du conducteur

E NOTA: Repita estos pasos 2-5 en el lado del chofer

G ANMERKUNG: Wiederhole Schritte 2-5 auf der Fahrer Seite

10