

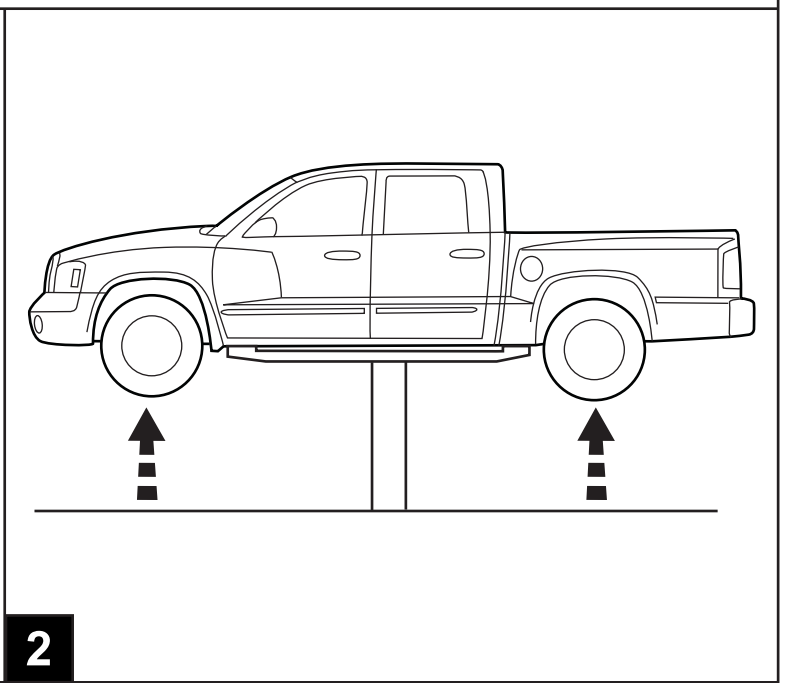

DODGE DAKOTA

Trailer Tow Harness

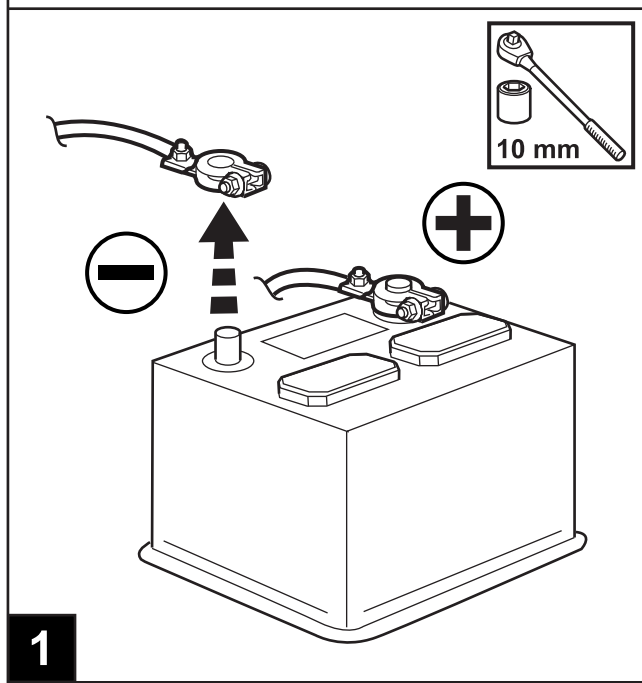

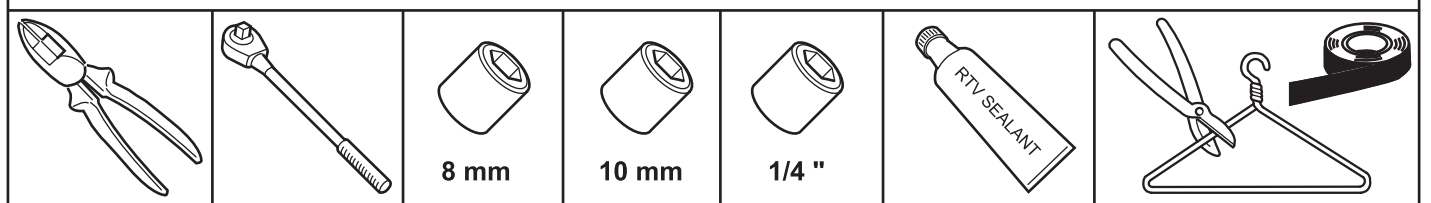
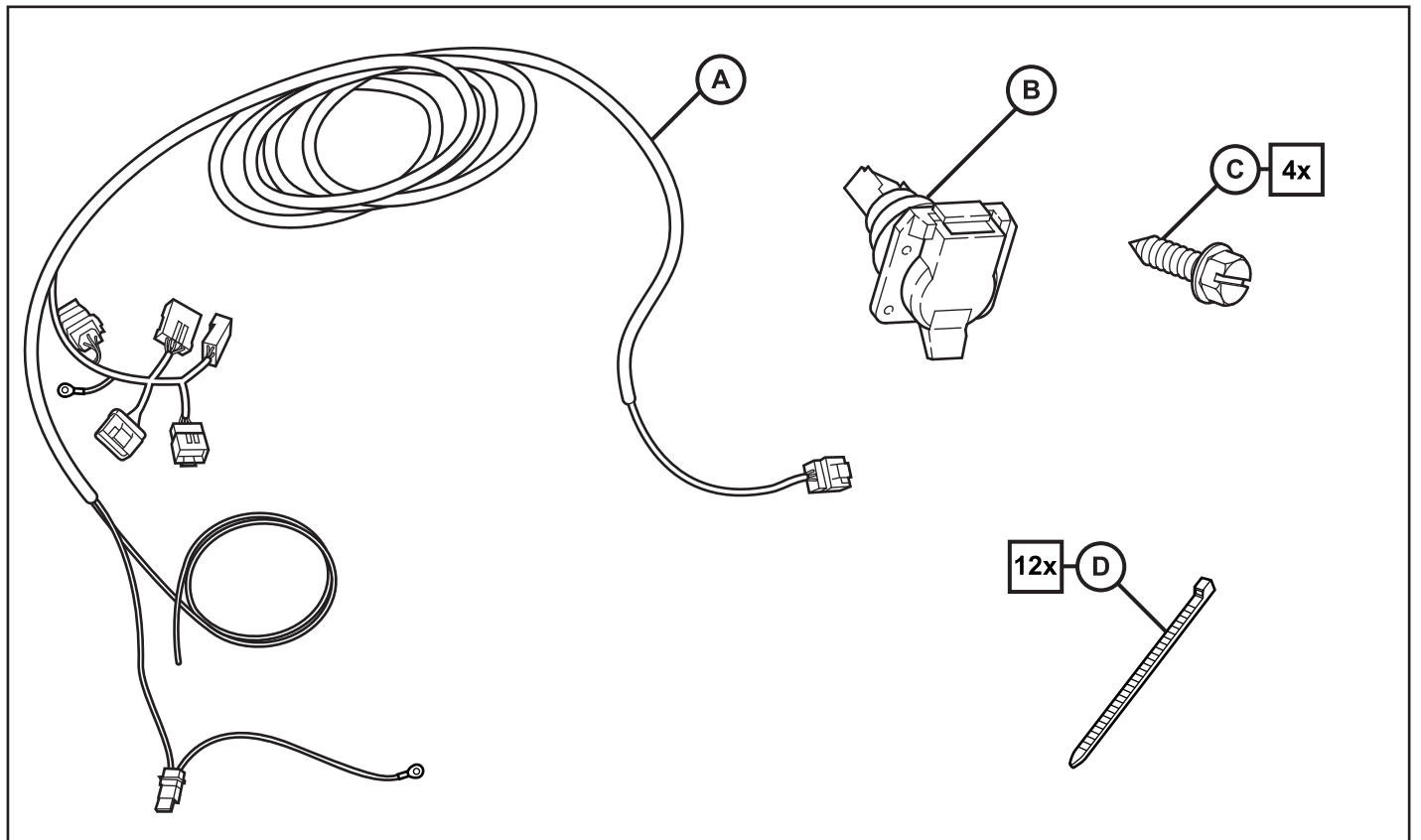
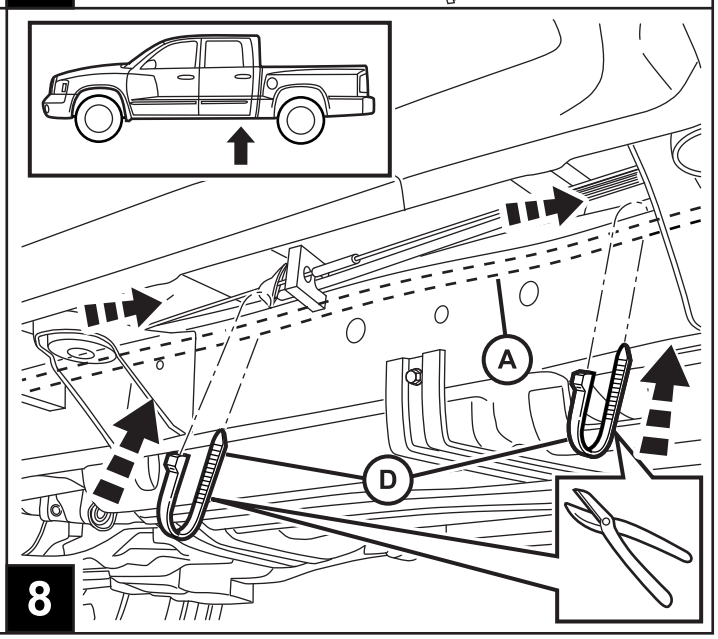
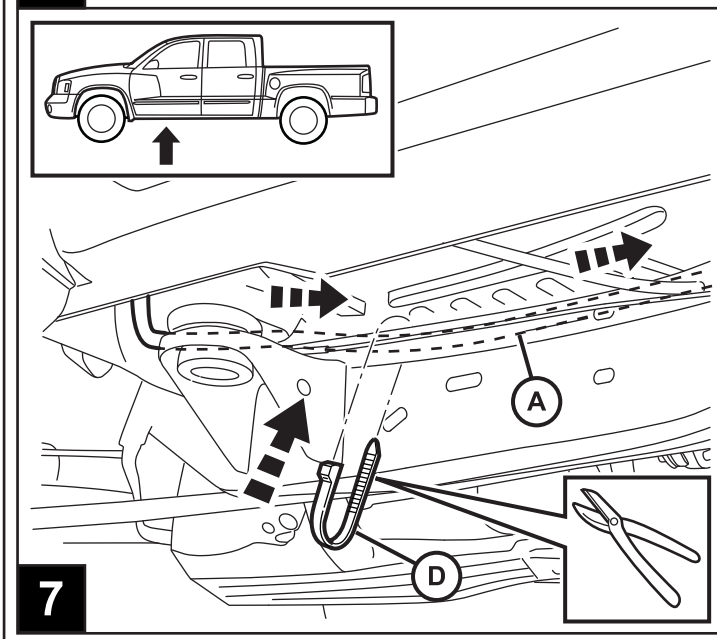
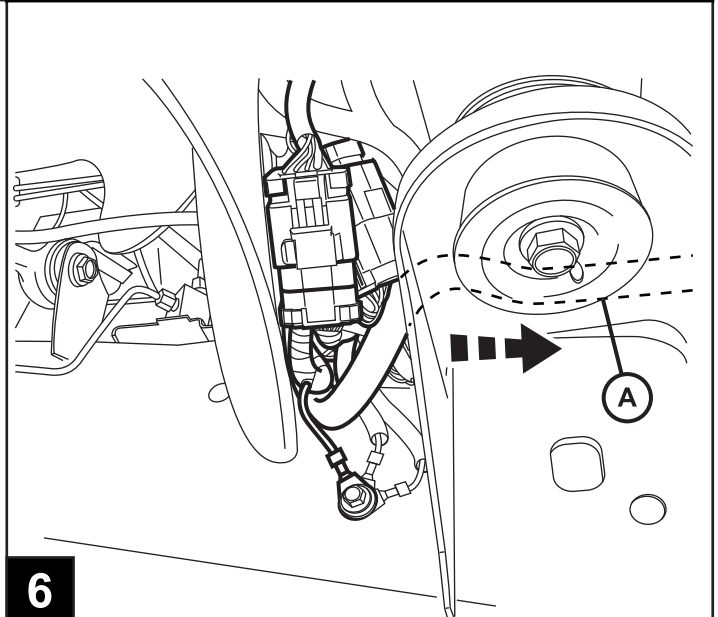
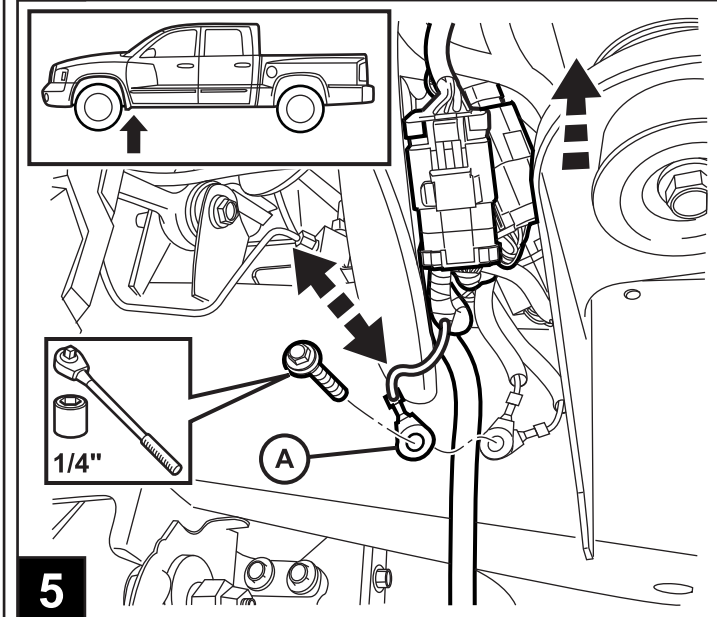
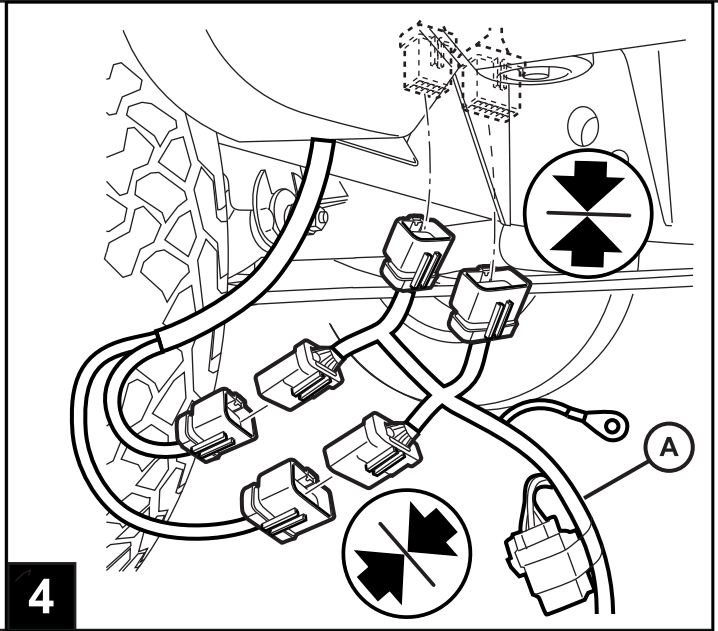
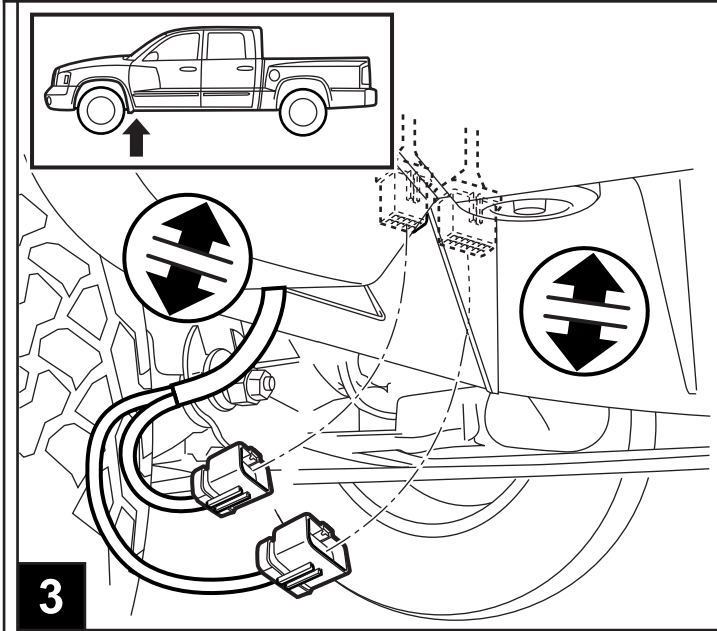

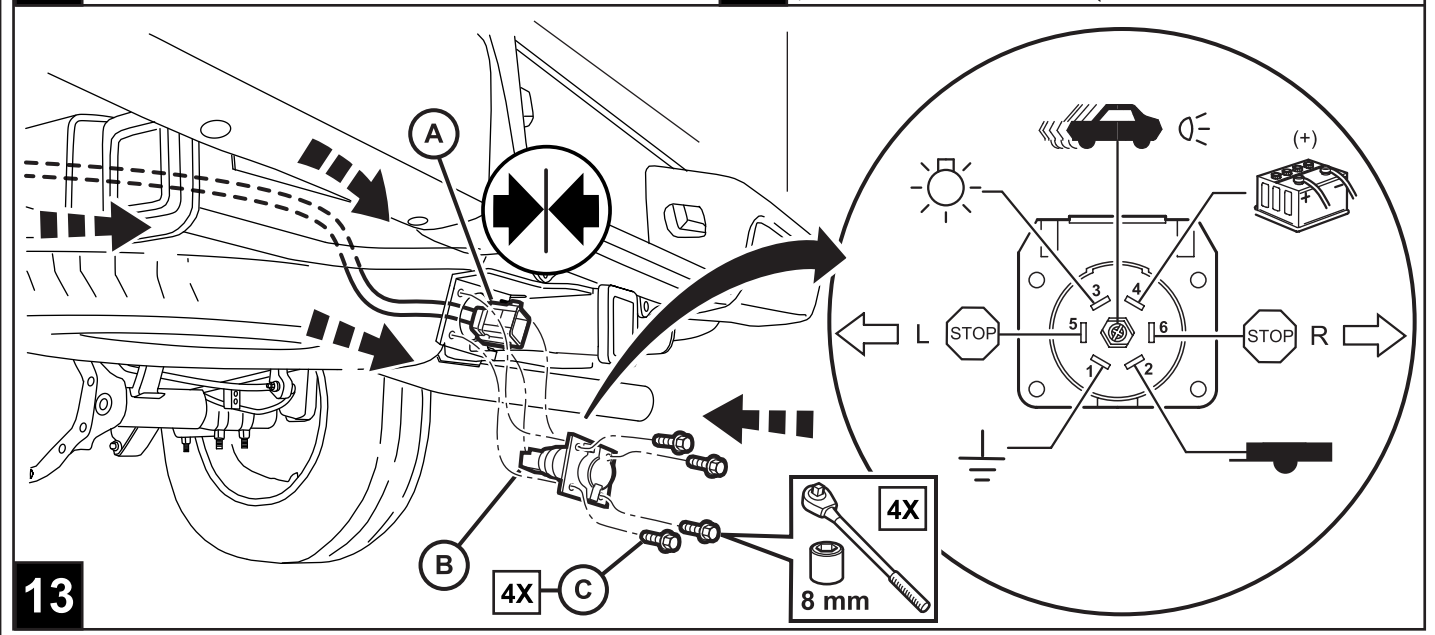
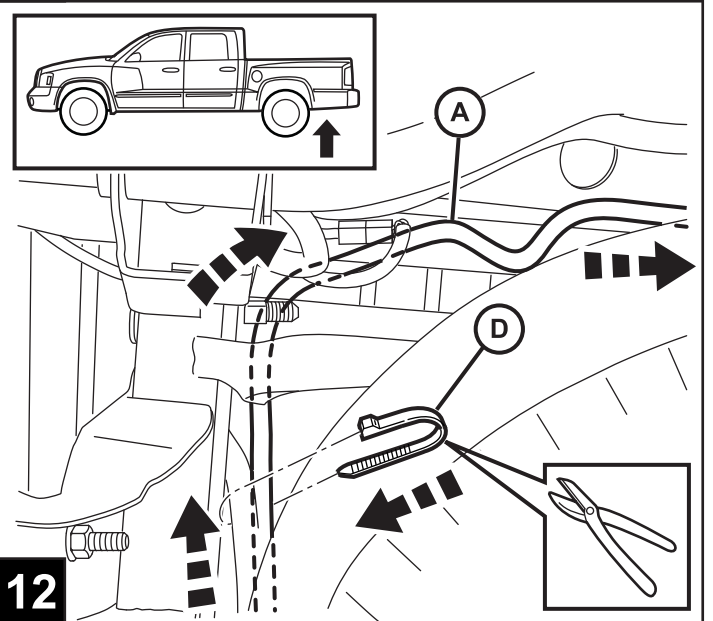
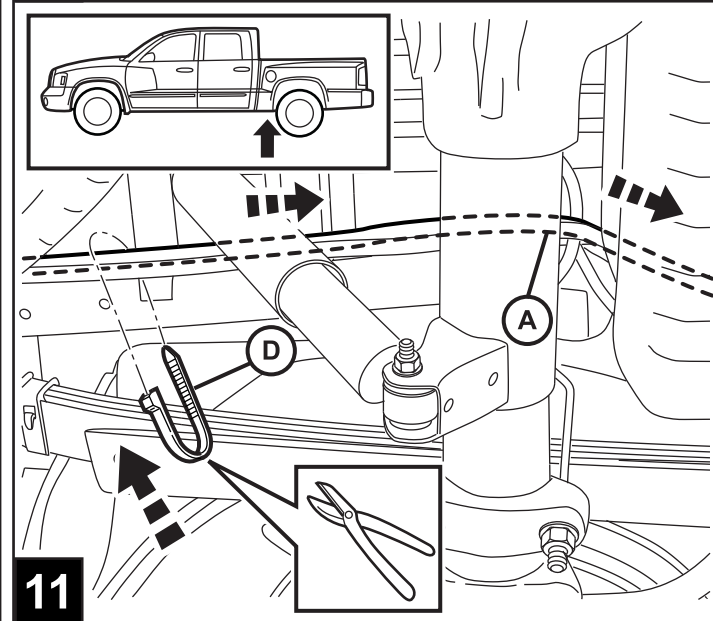
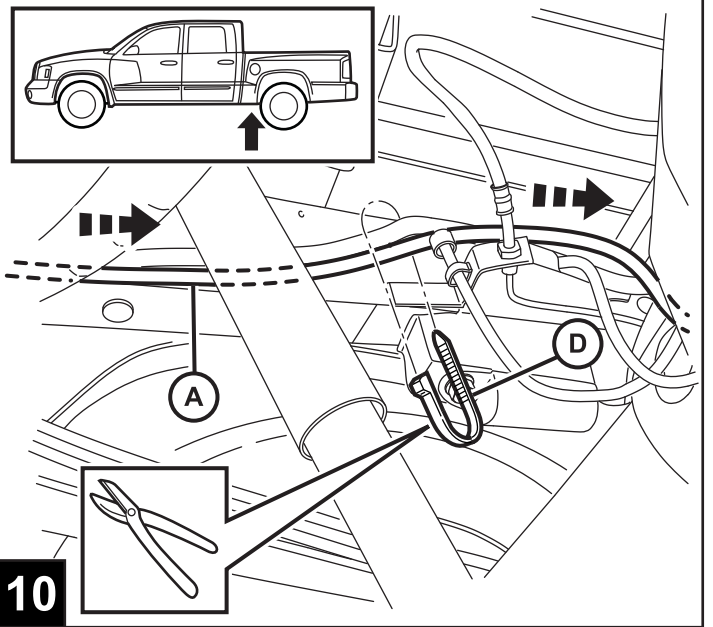
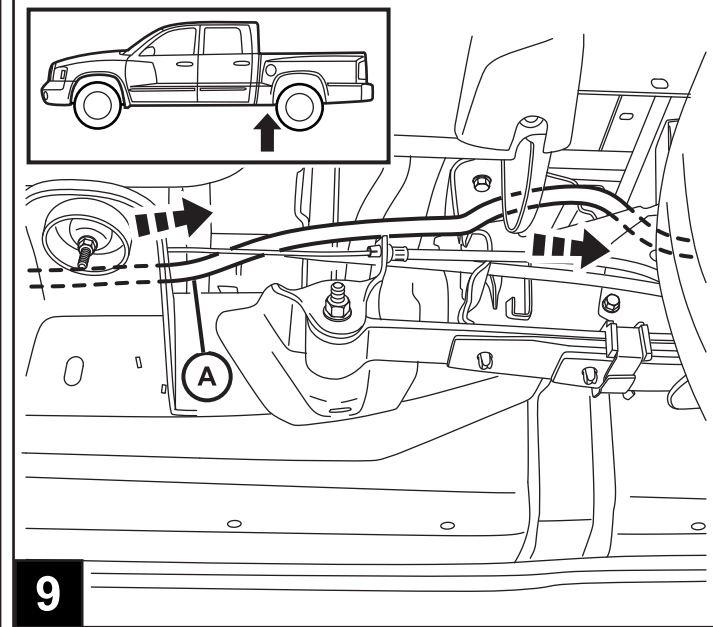

CAUTION

WHEN ROUTING TOW HARNESS THROUGH ENGINE COMPARTMENT, HARNESS MUST BE MOUNTED AWAY FROM EXHAUST MANIFOLD HEAT SHIELD AND EXHAUST PIPE.

PRECAUCIÓN

CUANDO ENCAUCE EL ARNÉS PARA REMOLQUE POR EL COMPARTIMIENTO DEL MOTOR, EL ARNÉS DEBERÁ ESTAR MONTADO A DISTANCIA DEL MÚLTIPLE DE ESCAPE, DEL PROTECTOR CONTRA CALOR Y DEL TUBO DE ESCAPE.

MISE EN GARDE

LORS DE L'ACHEMINEMENT DU FAISCEAU DE REMORQUAGE PAR LE COMPARTIMENT-MOTEUR, LE FAISCEAU DOIT ÊTRE POSITIONNÉ À L'ÉCART DU PROTECTEUR THERMIQUE DU COLLECTEUR D'ÉCHAPPEMENT ET DU TUYAU D'ÉCHAPPEMENT.

