

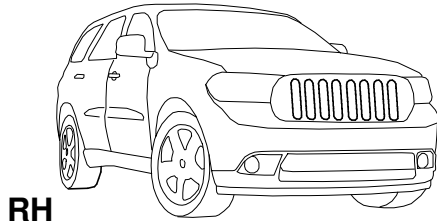

JEEP GRAND CHEROKEE

2011 →

RUNNING BOARDS ESTRIBOS LATERALES TUBULARES MARCHEPIEDS TUBULAIRES



RH

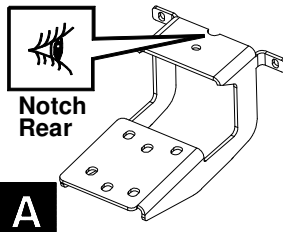

A

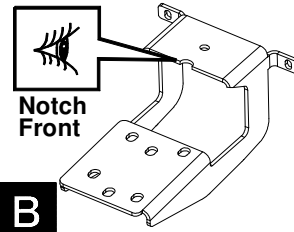

B

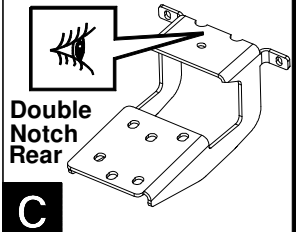

C

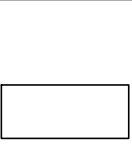

D 3X

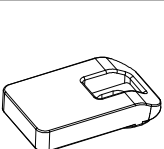

E 3X

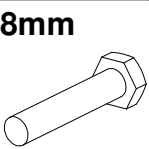

F 3X



G 9X

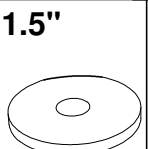

H 3X

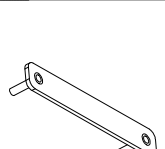

I 3X



J 6X

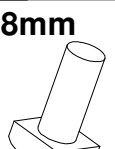

K 6X



L 12X



M

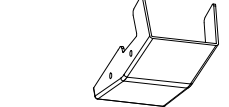

N 3X

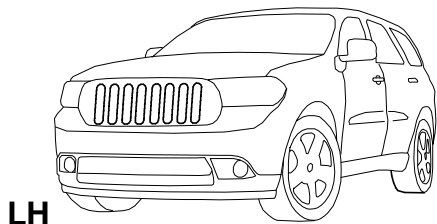

LH

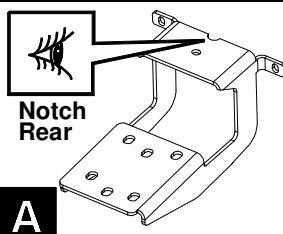

A

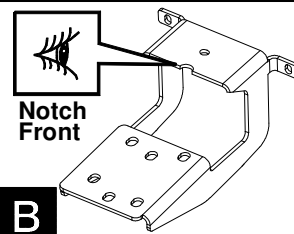

B

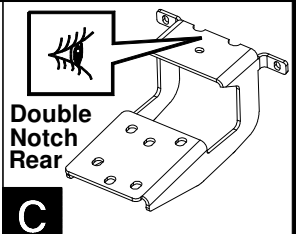

C

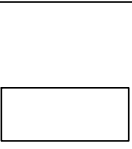

D 3X

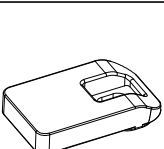

E 3X

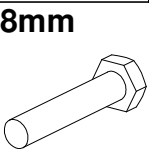

F 3X



G 9X

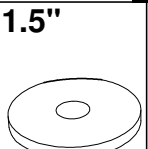

H 3X

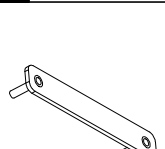

I 3X



J 6X

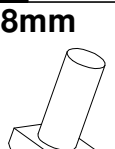

K 6X



L 12X



M

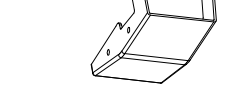

N 3X

PROBLEMS? QUESTIONS? PLEASE CALL:
PROBLEMAS? ¿PREGUNTAS? PÓNGASE EN CONTACTO CON:
DES PROBLÈMES ? DES QUESTION ? VEUILLEZ CONTACTER:

1-866-639-8896

FAX
FAX 1-515-299-4594
FAX

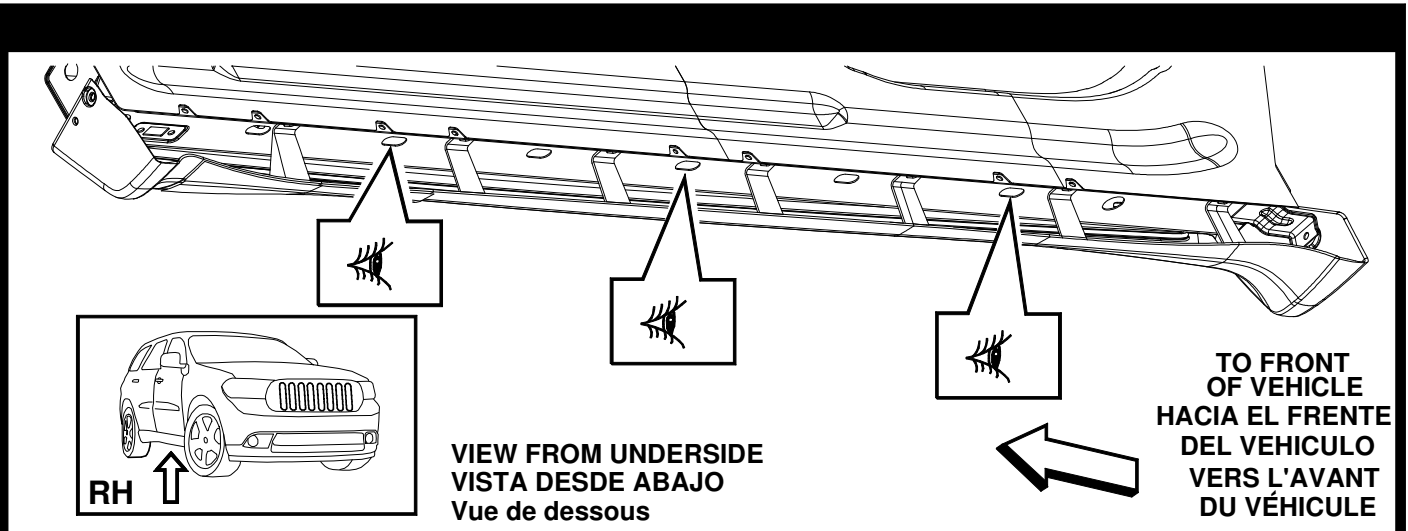

Add patch of Lock & Seal Adhesive - blue (#04318031) to bolt (F)
Insert Item F into Item E, and apply Item D as shown. Repeat 2 times for RH

Añadir parche de bloqueo y cierre adhesivo - azul (# 04318031) al perno (F)
F Insertar elemento en E del artículo, y aplicar artículo D como se muestra. Repita dos veces para la salud reproductiva

Ajouter patch de Lock & Seal Adhésif - bleu (# 04318031) sur la vis (F)
F Insérer un élément dans Point E, et appliquer le point D tel que montré. Répétez 2 fois pour RH

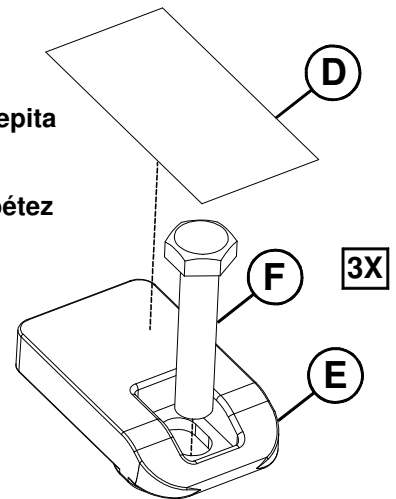
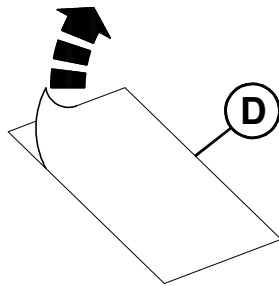

1

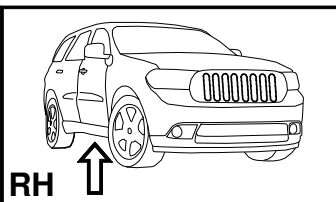
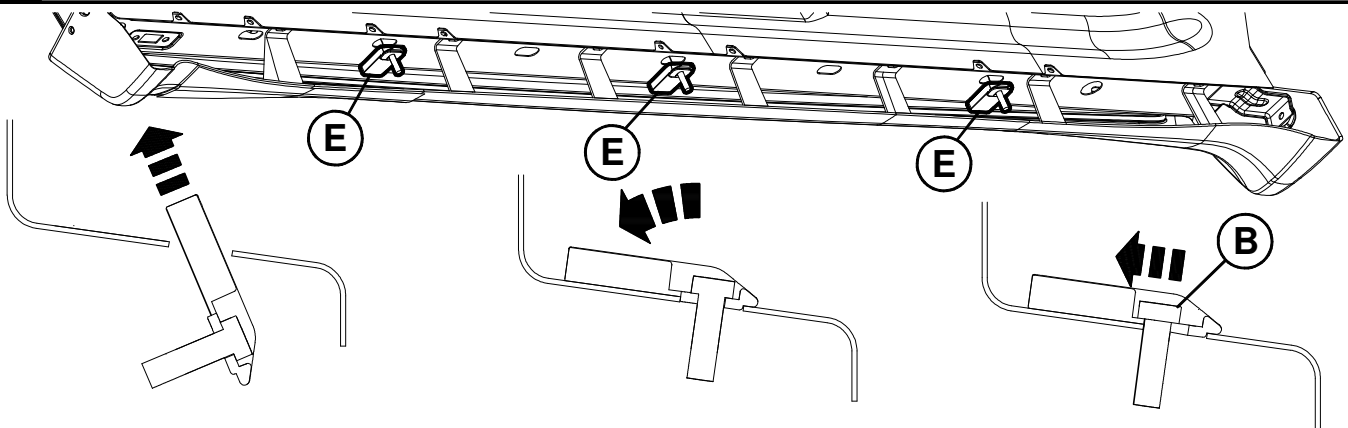

Using a paint marker, dot the bottom front of the bolt. Use this mark during installation to ensure the bolt plate assembly has not rotated. Insert Item E assembly into slot as shown.

Utilizando un marcador de pintura, de punto, la parte inferior del perno. Utilice esta marca durante la instalación para asegurar la placa de pernos no ha rotado. Insertar elemento de montaje E en la ranura como se muestra.

Utiliser un lanceur de peinture, dot la partie inférieure avant de la culasse. Utilisez cette marque lors de l'installation afin d'assurer l'ensemble de la plaque de boulon n'a pas tourné. Insérez le montage du Point E dans la fente comme indiqué.

2

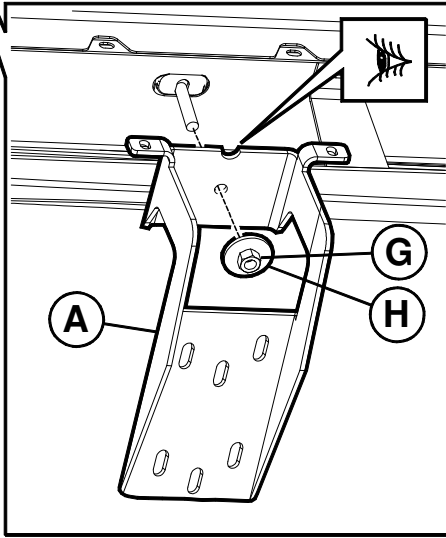
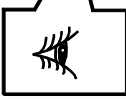
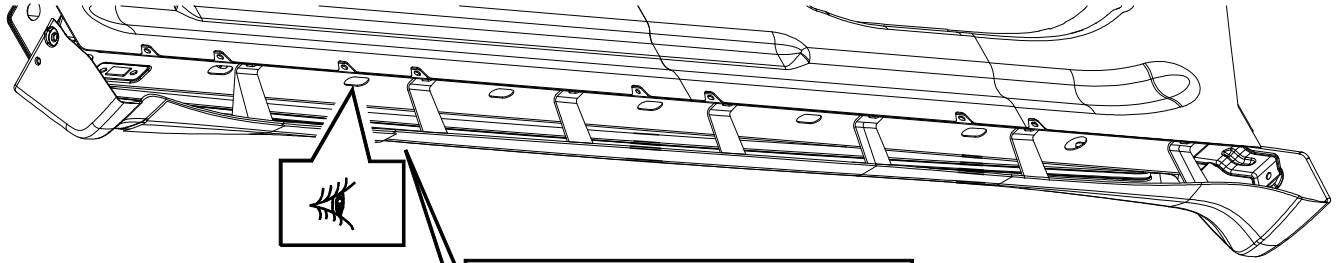

Keep assembly loose
Mantenga el conjunto suelto
Gardez assemblage lâche

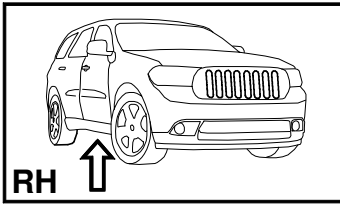

3

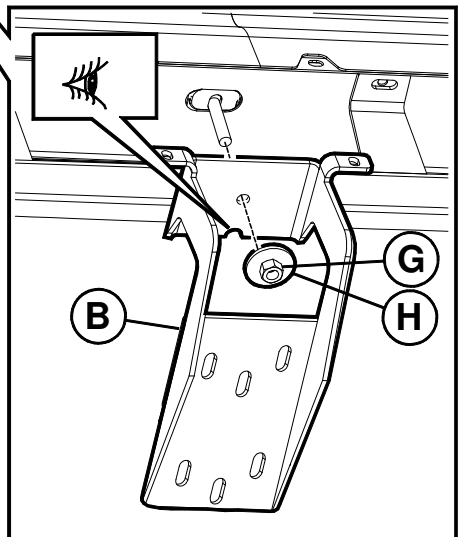
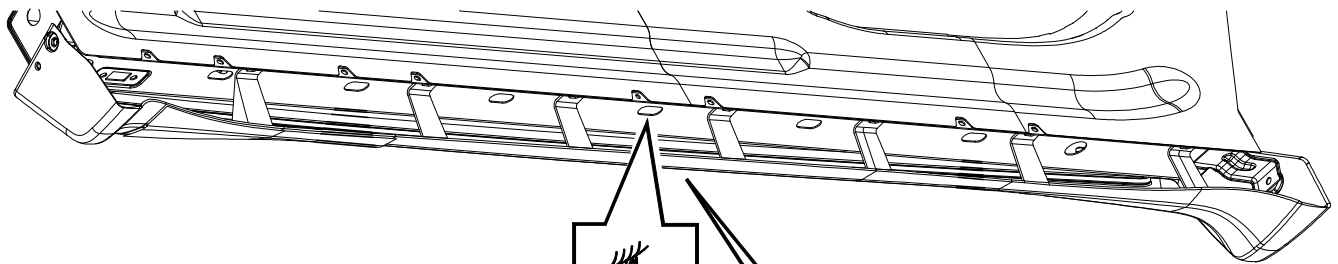

Keep assembly loose
Mantenga el conjunto suelto
Gardez assemblage lâche

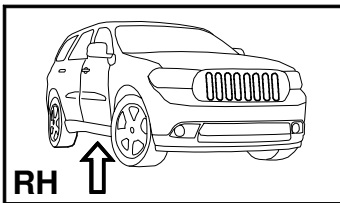

4

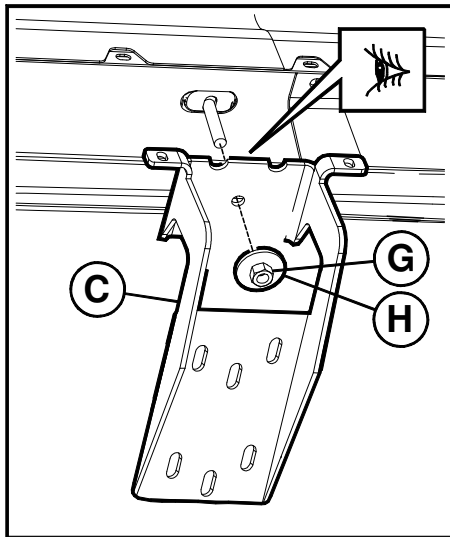
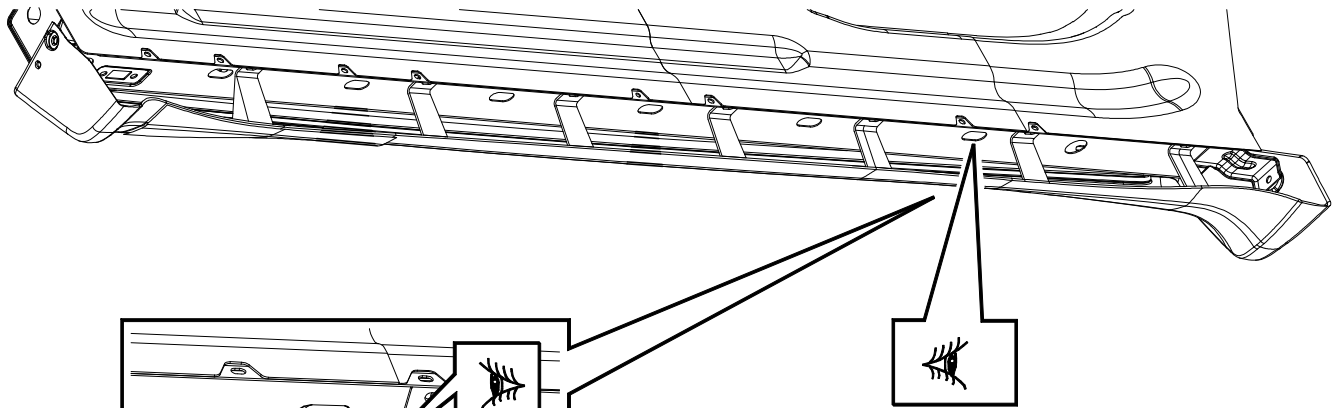

Keep assembly loose
 Mantenga el conjunto suelto
 Gardez assemblage lâche

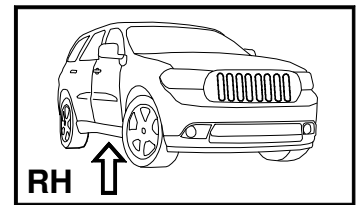

5

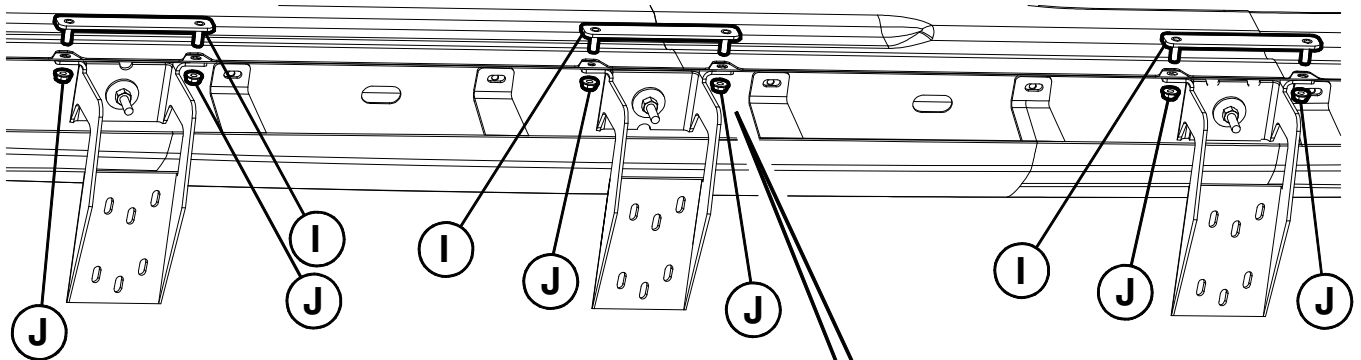

With Item I and Items J, attach as shown through pinch weld flange for each bracket location. Keep assembly loose

Con el artículo I y los artículos J, fije como se muestra a través de la brida pizca de soldadura para cada ubicación de los soportes. Mantenga el conjunto suelto

Avec l'article I et les points J, fixez comme indiqué par la bride pincée de soudure pour chaque support. Gardez assemblage lâche

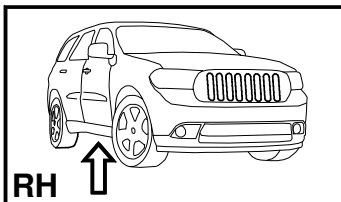
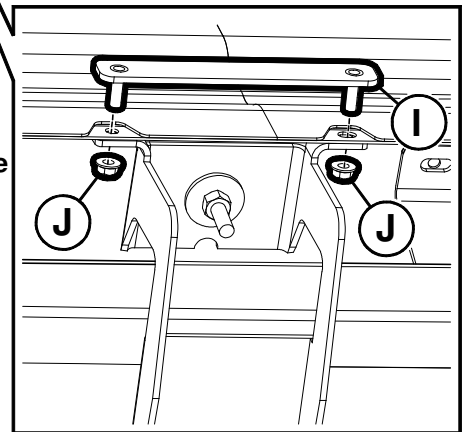

6

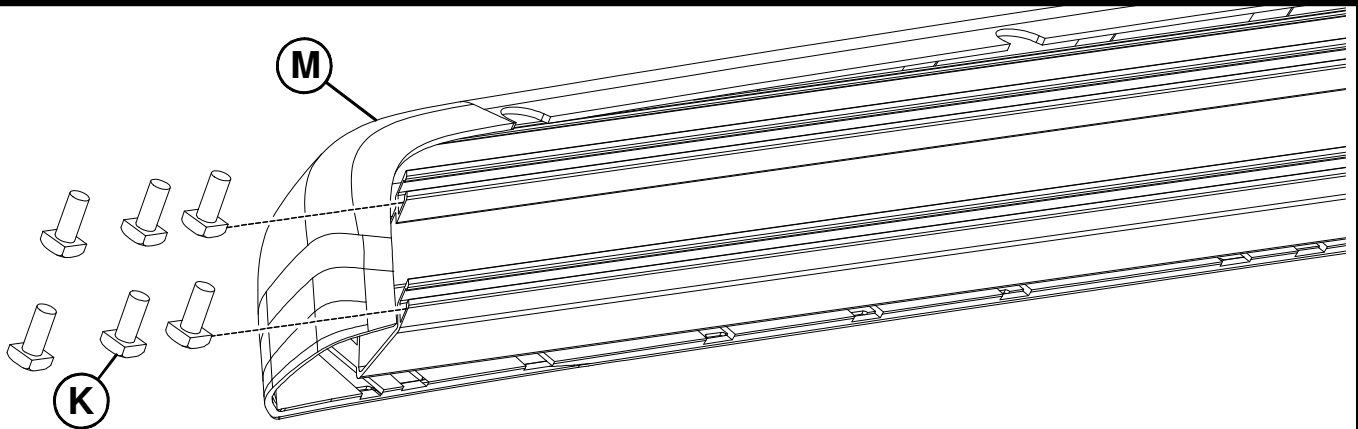

Insert Items K into Item M channels as shown
 Insertar elementos en los canales de K M del artículo tal como se muestra
 Insérer des éléments dans les canaux K M Point comme indiqué

7

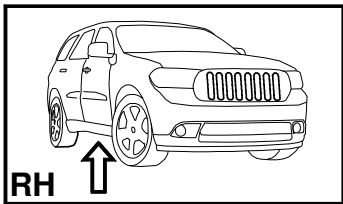
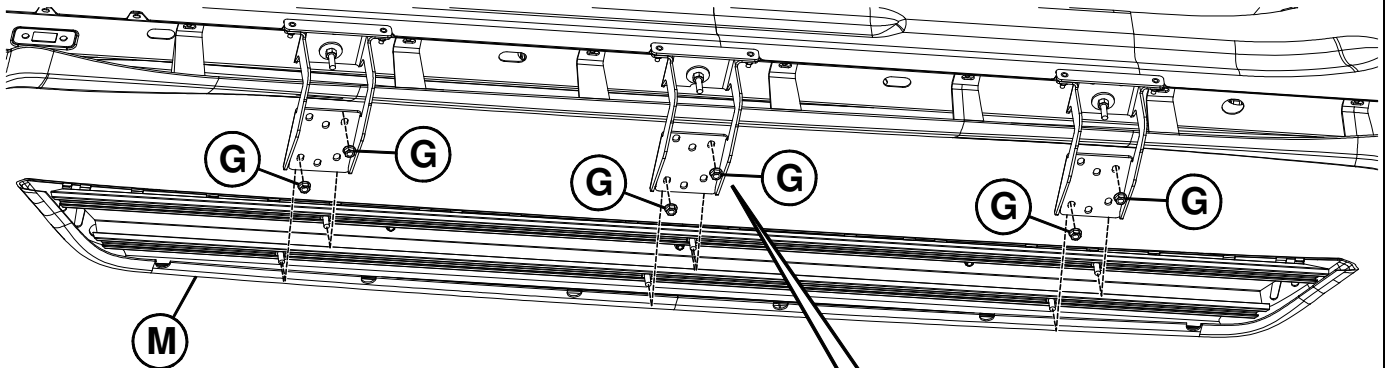

Set Running Board on Brackets, align bolts as shown, and secure with Items L. Keep assembly loose
 Bracket slots marked "1" for Durango
 Bracket slots marked "2" for Durango Heat Trim
 Bracket slots marked "3" for Grand Cherokee

Establecer estribos en los soportes, alinee los pernos como se muestra, y seguro con elementos de L. Mantenga el conjunto suelto
 Las ranuras del soporte marcado "1" para Durango
 Las ranuras del soporte marcado "2" para Durango Heat Trim
 Las ranuras del soporte "3" para el Grand Cherokee

Set Running Conseil sur les supports, alignez les boulons comme indiqué, et le fixer avec les articles L. Gardez assemblage lâche
 Fentes du support marqué "1" pour Durango
 Fentes du support "2" pour Durango Heat Trim
 Fentes du support portant la mention "3" pour Grand Cherokee

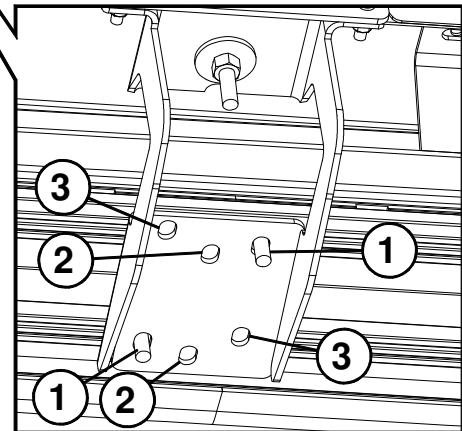

8

REPEAT STEPS 1-8 FOR LH PASOS PARA REPETIR 1.8 LH RÉPÉTER 1-8 pour LH

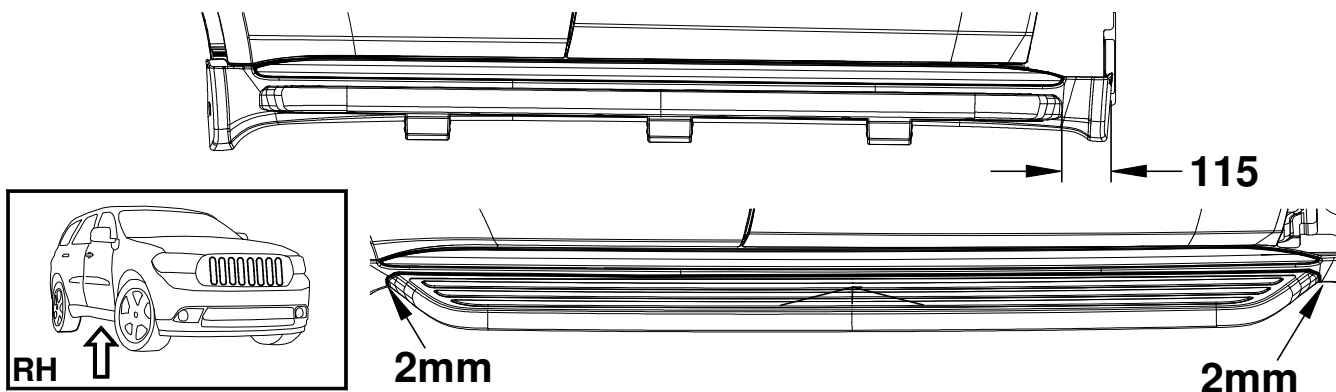

Position the running board (A) from the front as shown, maintaining a 2mm gap to the cladding, prior to tightening any fasteners.

Note: in order for step to be proper distance from the vehicle, the board must be lifted so the braces clear the plastic edge.

Coloque el estribo (A) de la parte delantera como se muestra, el mantenimiento de un espacio de 2mm para el revestimiento, antes de apretar los elementos de fijación.

Nota: para que paso a ser la distancia adecuada del vehículo, la junta tiene que ser levantado para que los aparatos transparentes el borde de plástico.

Placez le panneau courant (A) de l'avant comme indiqué, le maintien d'un écart de 2mm à la gaine, avant de serrer les attaches.

Remarque: pour étape à bonne distance du véhicule, le conseil doit être levé si les accolades claires bord en plastique.

9

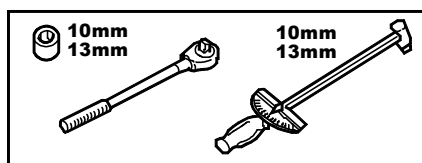
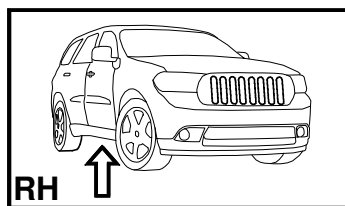
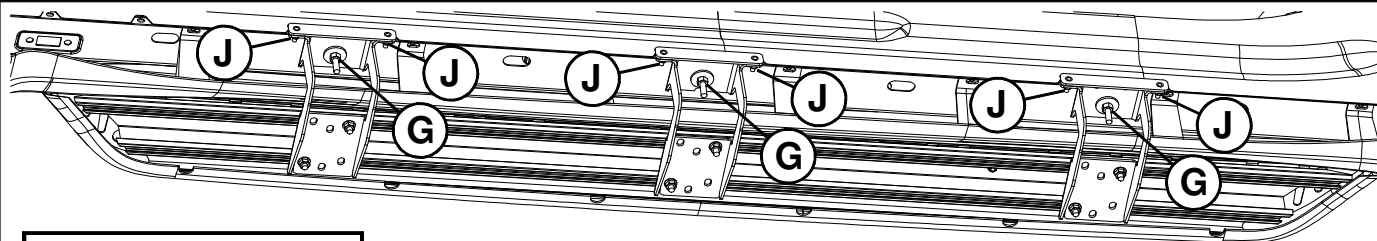

Tighten fasteners labeled "G" to 168 in-lbs \pm 12 in-lbs. (19 N-m \pm 1 N-m). Tighten fasteners labeled "J" to 70 in-lbs. (8 N-m). Repeat for driver's side. Ensure marked bolt has not rotated
CAUTION - Do Not Overtorque

Apriete los sujetadores con la etiqueta "G" a 168 pulgadas-libras \pm 12 pulgadas-libras. (19 Nm \pm 1 Nm). Apriete los sujetadores con la etiqueta "I" y 70 pulgadas-libras \pm 12 pulgadas-libras (8Nm). Repita para el lado del conductor. Asegúrese marcados perno no ha rotado. **PRECAUCIÓN - No apriete demasiado**

Resserrez les attaches "G" jusqu'à 168 in-lbs \pm 12 in-lbs. (19 N-m \pm 1 N-m). Resserrez les attaches "I" jusqu'à 70 in-lbs \pm 12 in-lbs. (8 N-m \pm 1 N-m). Repétez l'opération du côté aconducteur. **Assurez-vous marqué boulon n'a pas tourné. Attention: Ne pas surcoupler**

10

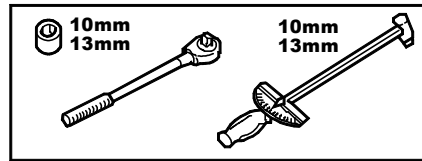
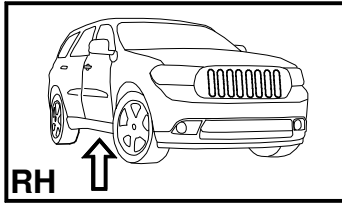
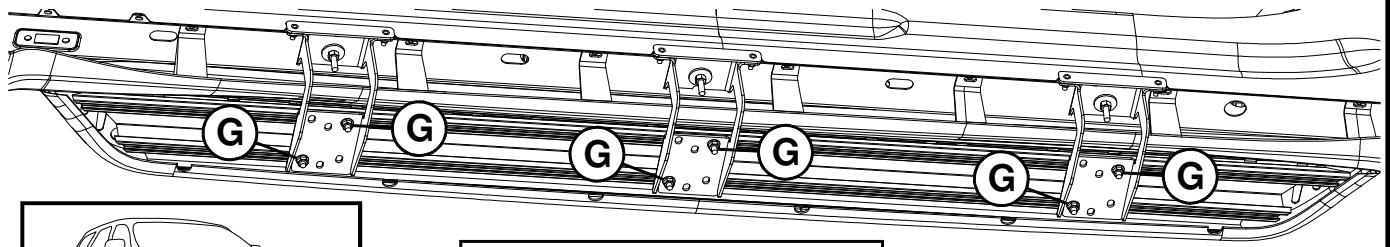

Tighten bolts attaching brackets to step to 100 in-lbs \pm 12 in-lbs. (17 N-m \pm 1 N-m). Repeat for LH.

CAUTION - Do Not Overtorque

Apriete los pernos de los soportes de fijación al paso a 100 pulgadas-libras \pm 12 pulgada-libras (17N-m \pm 1 Nm) Repita el procedimiento para la LH.

Precaucion: No apriete demasiado

Serrer les boulons les pattes de fixation à l'étape de 100 pouces-livres \pm 12 pouce-livres (17N-m \pm 1 Nm) Répétez l'opération pour LH.

Attention: Ne pas surcoupler

11

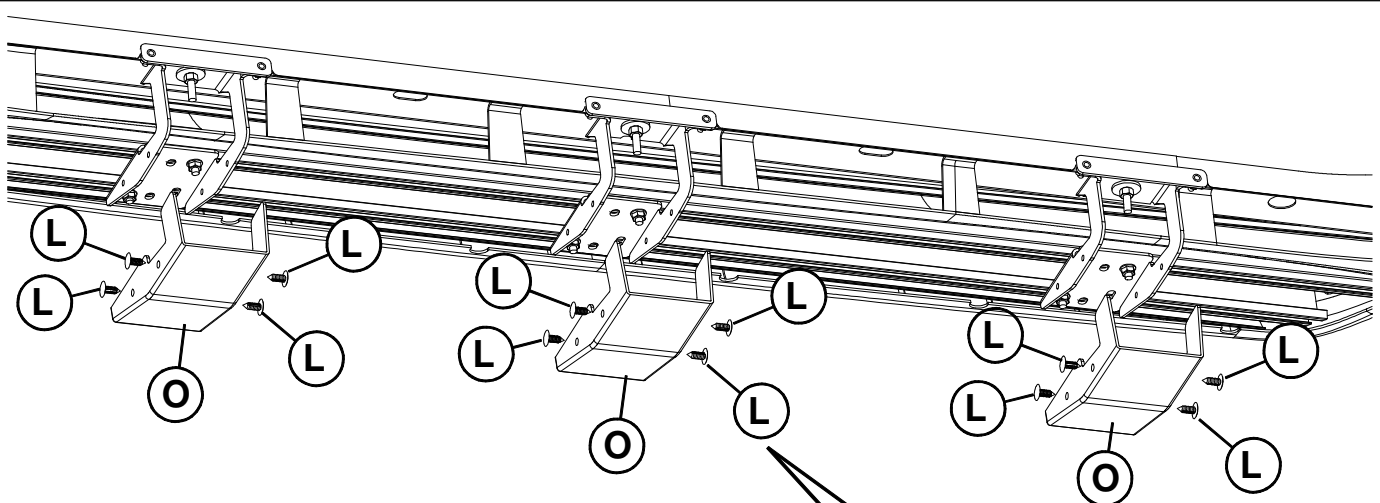

Attach Item O to brackets using Item L.

Adjuntar O artículo sobre los soportes con artículo L.

Fixez O Point de supports à l'aide d'article L.

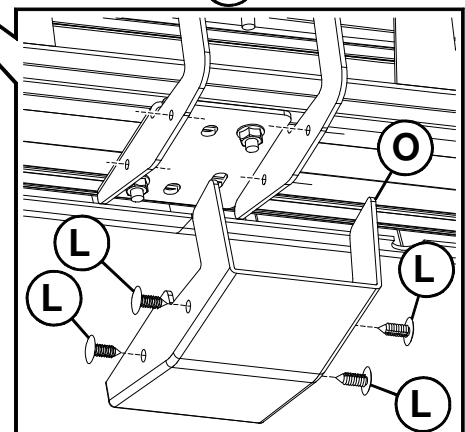
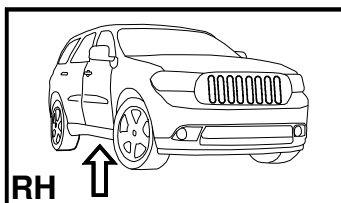

12

RH